

# SAMSON

Issue 8

# MAGAZINE

SAMSON MAGAZINE 2005

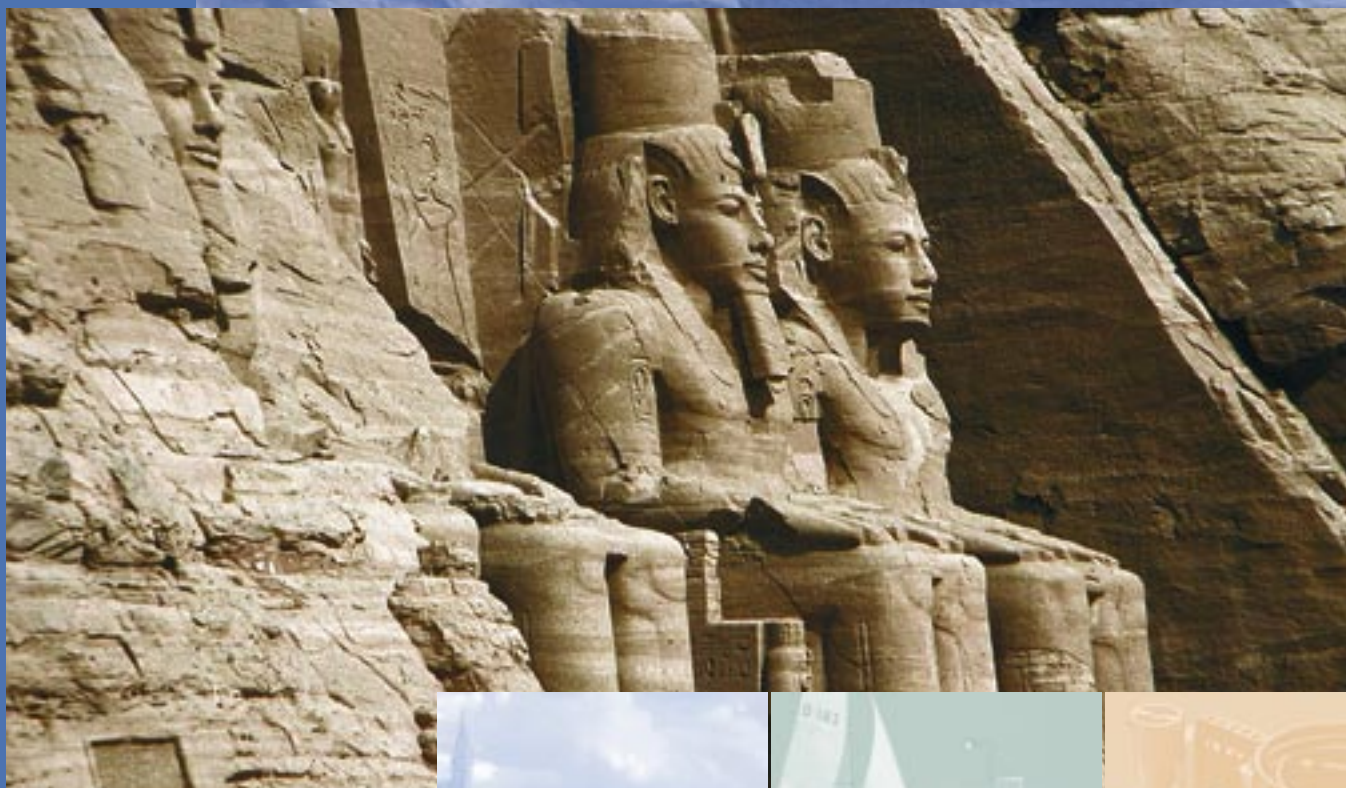

## Impulse

Electric actuators from SAMSON

## Report

Nothing's rotten in the state of Denmark

## Portrait

Swinging in  $\frac{3}{4}$  time

## Innovations

SAMSON's R&D test benches

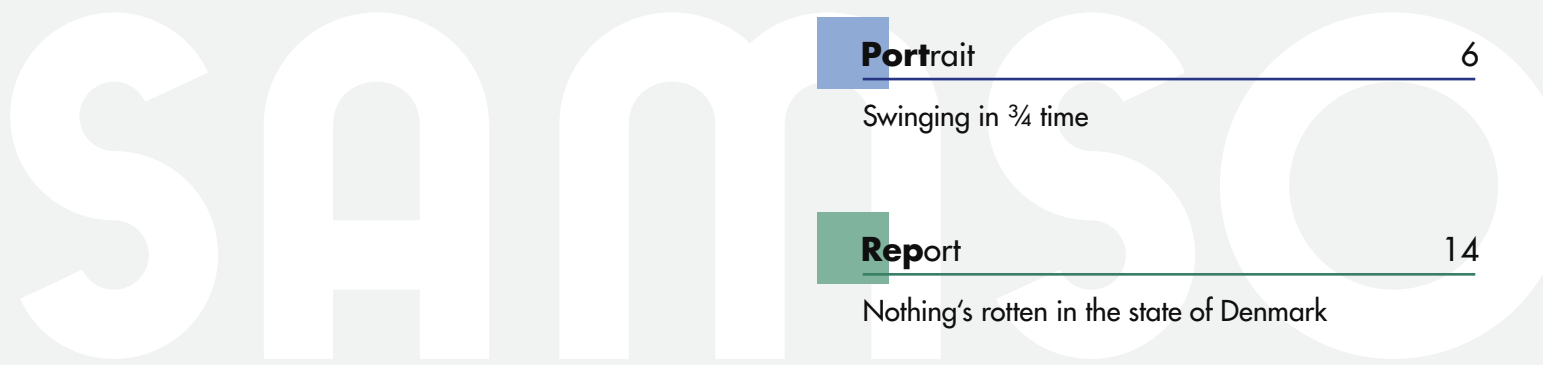
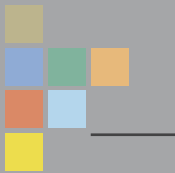

## Editorial 3

IFS Applications – added value for our customers

## Innovations 4

SAMSON's R&D test benches

## Portrait 6

Swinging in  $\frac{3}{4}$  time

## Report 14

Nothing's rotten in the state of Denmark

## Impulse 20

Electric actuators from SAMSON

## Special topic 22

Emission control using the bellows

## Facts and figures 24

SAMSON continues its success story

## Spotlight 26

New corporate software at SAMSON

### Cover

Abu Simbel in southern Egypt: Pharaoh Rameses II and his queen tower high above Lake Nasser. Rameses II (1290 – 1224 BC) had the twin temples carved into a sandstone cliff on the western bank of River Nile ([www.bigfoto.com](http://www.bigfoto.com)).

### Photo material

We wish to acknowledge media wien MA13, [www.bigfoto.com](http://www.bigfoto.com), voestalpine AG, VGBild-Kunst, Bonn 2005; Presse- und Informationsamt der Stadt Frankfurt am Main, Cool Sorption A/S, Silke Lohrberg, Florian Schüppel; Lieke Leenders, Guenter M. Kirchweger, Christian Bauer, ([www.sxc.hu](http://www.sxc.hu)), [www.photocase.com](http://www.photocase.com) as well as Ukendt, Lennard Nielsen, Mikkel Grabowski, Jørgen Schytte, Bob Krist, and Henrik Stenberg ([www.visitdenmark.com](http://www.visitdenmark.com)) for providing photo material.



## IFS Applications – added value for our customers

Dear Readers,

The city of Frankfurt am Main is a major center of commerce and the leading financial marketplace in Europe, sometimes fondly referred to as “Mainhattan” owing to its imposing skyline with its similarities to New York.

Frankfurt has also been home to SAMSON since 1916 after making the move from Düsseldorf. Consequently, we can look back on almost 100 years’ experience in the field of instrumentation and controls in our Frankfurt headquarters.

To meet the demands of the increasingly globalized marketplace, SAMSON has expanded its sales network with subsidiaries and representatives located all around the globe. The challenges that we face include satisfying customer requirements and maintaining our competitive edge. Not just prices and lead times play a decisive role in the international marketplace. Reliable customer relationships are also a key factor. As part of our philosophy of providing excellent customer support, SAMSON’s well-trained staff are always at hand to assist.

Examples illustrating our successful customer support in the oil and gas industry, in steel production as well as in the district heating sector are described in the articles in this magazine on our Danish subsidiary located near Copenhagen, in Birkerød, and our Austrian subsidiary in Vienna. Both capitals belong to the most appealing cities that Europe has

to offer. Their great atmosphere and numerous places of interest make them well worth a visit.

To continue fulfilling customer demands while maintaining the high level of quality achieved at SAMSON, a new corporate software, IFS Applications, was introduced at the Frankfurt headquarters at the beginning of 2005. Extensive work was involved in implementing the business processes into the IT system owing to the broad range of products with the countless number of product configurations. The IFS business solution provided the appropriate components. However, the software had to be customized on account of the specific needs. Our article on page 26 gives an inside look into this new solution.

We hope you enjoy reading the magazine.

Best regards,

A handwritten signature in blue ink, appearing to read 'Stephan Voigt'. The signature is fluid and cursive.

Stephan Voigt  
Head of EU Sales

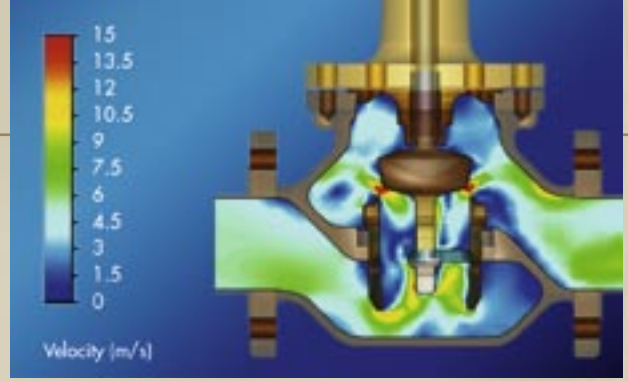

Computer-based flow simulations illustrate the distribution of velocities inside a valve.

Theory vs. experience

## SAMSON's R&D test benches

A large number of legally binding standards, directives, regulations, and material specifications need to be observed in all fields of engineering, providing engineers with a secure basis for strength calculations, for example. Yet, these rules leave hardly any space for individual engineering solutions. Many standards, such as those stipulating calculation methods for the flow rate and noise level in valves, only produce reliable results if they are based on valve parameters that cannot be exactly calculated beforehand, but need to be tested empirically. For accurate measurements of flow and noise-specific parameters, SAMSON introduced a water-operated test bench already in 1968 that received wide acclaim. In the meantime, the test benches have continually been upgraded to meet the latest technological requirements, their performance has been enhanced, and additional test benches for vapor and pneumatic applications have been added. Moreover, SAMSON is the only valve manufacturer worldwide to have set up a test bench for flashing. No wonder that a lot of findings gained in this sophisticated environment have been incorporated into international standards.



Automated measurements of valve-specific parameters can be performed across the entire travel range.



The test bench for flashing applications helps analyze the effects of two-phase flows on erosion and the noise level.

## Basic research ensures long-term success

**Perfecting valve properties** – It is not the prime task of the test bench to measure the valve-specific parameters depending on the travel or opening angle, but to constantly improve them. This is a rather difficult job if we keep in mind that any measure taken to increase the flow coefficient usually causes all other parameters that benefit from a low pressure recovery to worsen.

Apart from optimizing and perfecting the properties of the valves and associated components, such as fixed restrictions and silencers, the SAMSON test benches are also used to do basic research, partly in cooperation with leading German universities. A major field of research includes improving noise level calculation as well as further refining the existing equations used to calculate parameters of two-phase flows and laminar flows in micro-flow valves. Moreover, fatigue strength and erosion resistance are tested and transit times are determined for complex systems composed of valve, actuator, positioner, volume booster, and solenoid valve.

**Validating prior calculations** – Experimental flow analyses go hand-in-hand with computer-based flow simulations. Thanks to the simulations, the distribution of pressures and velocities inside a valve can be analyzed already in the early construction stages, which would otherwise be rather difficult to do and require complex measurements. The simulation results are then verified and confirmed by experiments conducted on the appropriate test benches. Any deviation between theory and practice unveiled by the experiments is used to refine the existing theoretical model.

**Trusting excellent equipment** – The technical equipment of the SAMSON test bench is almost unparalleled. On the water test bench powered by four pumps, which provide a total power of 240 kW, dif-

ferential pressures of up to 40 bar and flow rates of up to 1,000 m<sup>3</sup>/h can be generated depending on how the pumps are arranged. All test benches, which can also be used for three-way valves, are controlled by an automation system developed by SAMSON and a PROFIBUS process control system. The pneumatic test bench is fed by buffer tanks providing 100 m<sup>3</sup> of air, allowing the test bench to supply an initial upstream pressure of 11 bar and a flow rate of 40 t/h. The test bench for vapor applications is suitable for continuous operation with flow rates of 5 t/h of superheated steam at temperatures up to 230 °C and a maximum differential pressure of 12 bar. Two-phase flows can be examined on the bench for flashing operation. The bench's heat exchanger supplies 90 m<sup>3</sup> of hot water per hour at a temperature of 140 °C and a pressure of 15 bar.

All test benches for liquid media are equipped with inductive flow meters. The vapor test bench includes an orifice meter.

**Measuring noise levels** – A multitude of microphones, piezoelectric pressure sensors, noise level gages, and frequency analyzers is available for measurements of airborne noise emissions and the noise level inside the pipes. To measure the static and dynamic forces as well as torques that act on the valve trim, the test benches are equipped with self-developed measuring equipment and strain gage load cells, shaft torque meters, and inductive travel sensors.

Having gathered such great valve expertise around the SAMSON test benches, the next logical step was to also entrust these specialists with developing the SAMSON Valve Sizing program and the SAMSON EXPERT valve diagnostics software, which is integrated into the high-end versions (-2 and higher) of SAMSON's Type 3730 Positioners.



Vienna has more to offer than Sisi and St. Stephen's Cathedral. The city is also home to a UN office (above) and the OPEC headquarters.

## High spirits in the Alps

# Swinging in $\frac{3}{4}$ time

Hiking through the towering Dachstein mountains in spring, sailing on glittering Lake Neusiedl in summer, hitting the Arlberg slopes blanketed in pristine snow in winter, or waltzing through Vienna on New Year's Eve—Austria figures among the most popular holiday destinations at any time of year, attracting over 18 million visitors from abroad annually. Yet, not only the tourism industry is booming; the general economic trend sparks high hopes as well.

Currently, Austria ranks among the world's richest countries and is one of the top investors in the new EU economies. Its unemployment rate is far lower, its GDP much higher, than EU average. The growth estimates for 2005 are equally positive.

The good mood is also fostered by the numerous special celebrations to be held in Austria in 2005. Apart from the usual cultural festivals that Austria prides itself on, the country will celebrate 50 years of Austrian independence, of Austrian membership in the UN, and of the reopening of the Vienna State Opera and Burgtheater. The 100<sup>th</sup> anniversary of the first woman winning the Nobel Peace Prize, Bertha von Suttner, and the bicentenary of the writer Adalbert Stifter are to be celebrated as well—great events lie ahead in the Alpine republic.



Since 2001, the city of Lienz has been operating a biomass heating plant. SAMSON supplied the control equipment for over 1,000 heating stations.



Perfect for skiing and other winter activities: The Serfaus-Fiss-Ladis resort high above the Inn valley offers great slopes as well as perfectly prepared snow hiking trails.

## Bridging the gap between the Old and the New

**Ideal corporate climate** – There are various reasons that explain why the Austrian economy is doing so well: To ensure long-term growth and attract foreign investment, corporate taxes have been cut back, the expenditure on research has been increased, and the streamlining of bureaucracy has been continued. Nevertheless, not only recent developments have added to Austria's success. Political stability, the high skill level of employees as well as social freedom and stability have been major assets. The good partnership between employers' associations and the Austrian government can look back on a long tradition, helping to reach equally beneficial agreements and thus playing an important role in the social and economic policies of the country.

**No future without tradition** – As a result, Austria can serve as a good example that tradition and modernization are not always incompatible. The contradictory question of conservation vs. change has always been animatedly discussed, maybe because those in favor of modernizing have always faced an opposition of people wanting to stick with the things exactly as they have been. However, the Austrians have repeatedly made radical decisions that strongly undermine their image of being trapped in tradition. For example, hardly anyone knows that the history of Vienna is marked by at least one drastic change: At the end of the 19<sup>th</sup> century, the population decided to tear down the inner city almost entirely and rebuild it according to the latest trend.

Still today, Vienna, as the political, economic, and administrative center of the country, manages to bridge the gap between the Old and the New. Many visitors are still attracted by the city's rich cultural and architectural heritage as well as by the legendary imperial couple, Empress-consort Elisabeth or Sisi and her husband Emperor Franz Joseph I, and their vari-

ous places of residence. Apart from the Old, Vienna has launched a number of projects to remodel its face, for example the Gasometer City. An entirely new urban district with residential and office buildings as well as a huge shopping mall was created east of Vienna around Europe's formerly largest gasworks. The Giant Ferris Wheel at the Prater amusement park is the perfect place to enjoy the view over the impressive skyline of the city, which is home to one of three UN offices away from the New York headquarters; the others being located in Geneva and Nairobi. Despite the modern architecture of the "UNO City", as the office buildings are commonly known, the UN office itself is rather a symbol of tradition as Austria, and Vienna in particular, have always considered themselves perpetually neutral places of international exchange embedded in a united Europe.

These developments show that little touch-ups are welcome, but breaking with tradition is not necessarily received well. And it is thus no surprise that the



The Giant Ferris Wheel at Prater has been spinning since 1897. Emperor Franz Joseph I received it as a gift from Britain for his golden jubilee.



Graz is the capital and most important industrial center of Styria. · Salzburg, Mozart's birth city below the Hohensalzburg fortress, has staged the famous annual Salzburg Festival of music and drama since 1920.

stories and tales from the old days are still part of everyday life and continue to be told with great enthusiasm.

**Tales from the Vienna Woods** – This title was selected by the waltz king Johann Strauss for a composition in 1868 and adopted by the playwright Ödön von Horváth for one of his plays in 1931. And indeed, some of the tales are still worth telling, simply because they express the charm that radiates from the country and its capital. There is, for example, the legend of how the first Viennese coffeehouse was founded.

It was on 12 September 1683—the Islamic Ottoman empire had just attacked and sieged Vienna for the second time—that the Ottoman troops could finally be defeated in the decisive Battle of Vienna near the Kahlenberg mountain. Vienna, the city at the foothills of the Vienna Woods, was free again. It is said that the besiegers were forced to retreat so hurriedly that they left behind a few linen sacks filled with strange beans. The Viennese found them and could not make anything of their content. After some debating, the finders agreed that the beans had to be camel feed. As there were no camels in Vienna at that time, they decided to burn the beans. Fortunately, the imperial interpreter Georg Franz Kolschitzky intervened at the last moment and took possession of the sacks. Legend has it that, three years later, Kolschitzky opened the first Viennese coffeehouse with exactly those beans. Historians, on the other hand, believe that the first Viennese coffeehouse was opened in 1685 by a Greek citizen quite unspectacularly and entirely without intervention by an imperial ambassador.

**Spaces detached from time** – Regardless of which tale is actually true, a tradition known the world over has evolved around the Viennese coffeehouses anyway. Who has not heard of the much-praised special at-

mosphere of the Viennese cafés, inviting visitors to linger for hours while leafing through the laid-out newspapers and reveling in the famous coffee specialties such as *Melange*, *Kleiner Brauner*, or a strong *Mokka* with the obligatory glass of water at the side? Letting time pass by and getting away from the worries of the world is part of the typical Viennese lifestyle that both locals and visitors love to enjoy in Vienna's over 2,600 cafés.

The typical *Melange*—consisting of equal amounts of hot milk and mokka coffee, topped off with lots of frothed milk—has posed an insurmountable obstacle even to the Seattle-based café chain Starbucks. The Viennese coffee specialty has been added to Starbucks' coffee range but, no wonder, only in its Vienna shops. The coffeehouse myth was further perpetuated by the so-called *coffeehouse writers* active in the transitional period from the 19<sup>th</sup> to the 20<sup>th</sup> century. Many of them, including Karl Kraus, Alfred Polgar, Hermann Broch, and Friedrich Torberg, centered their life and work around their favorite coffeehouse.

**Unique atmosphere** – As a result, an absolute must for all coffeehouse enthusiasts is a visit to Café Hawelka, one of the still existing traditional coffeehouses frequented not only by Austrian artists and writers: Elias Canetti, Arthur Miller, and Andy Warhol, to name but a few, were in-



Sacher Torte, a marmelade-filled chocolate cake, has become the symbol of Viennese confectionery.





After more than 1700 years of mining, voestalpine's Styrian iron ore mine on the Erzberg still produces two million tons of iron ore a year.



The economic growth in China favored an increase in the worldwide steel production to more than a billion tons a year—a promising market for voestalpine.

spired by the slightly smoky atmosphere of the Hawelka. For over 60 years, the owners Leopold and Josefine Hawelka have run the café along the same lines day in, day out, always occupying the number one spot among Vienna's artist cafés. A visit to the Hawelka would be incomplete without trying Josefine's famous *Buchteln*, the much-appreciated yeast buns that are filled with plum or apricot jam and served hot with prune jam or custard. In line with Hawelka tradition, fresh *Buchteln* are not served before 10 p.m. each night, filling the café with their sweet smell. Up until now, the Hawelkas' only concession to modern age was to install an espresso machine.

**SAMSON tradition and development** – SAMSON Mess- und Regelgeräte Gesellschaft m.b.H., SAMSON's Austrian subsidiary, has experienced massive changes in the past 39 years since it was founded in a former carriage works building located in Vienna's industrial district, Ottakring. The number of staff has grown from five in 1966 to 26 at present. In 1980, lack of space caused the subsidiary's headquarters to be moved from Vienna's 16<sup>th</sup> district to new, easier and more conveniently accessible office and storage facilities in the 13<sup>th</sup> district. In addition, two branch offices have been added in Linz, Upper Austria, and Kematen, Tyrol. Apart from the chemical, the food-processing, and the pulp and paper industries, district heating has become an important market for SAMSON Austria. Nevertheless, not everything is subject to change. In fact, the staff do not play football in the yard any longer during the lunch break as they used to do in Ottakring. And no more footballs land on the first-floor balcony between the freshly laundered clothes of the subsidiary head who used to live there with his wife. But team spirit and cooperation among the staff still play a major role for

## Steel—a strong tradition

In 1995, VOEST-ALPINE STAHL AG, a traditional company headquartered in Austria, was faced with near bankruptcy. Its listing on the Vienna Stock Exchange marked the first step in the privatization of the company 117 years after its foundation. Today, there is no sign of crisis anymore. Renamed to voestalpine AG, the Austrian group has become a symbol of quality and innovation. In Europe, the steel giant is one of the most profitable companies of the sector with an annual turnover of more than four billion euros. About sixty percent of the crude steel produced worldwide is still made according to the Linz-Donawitz method (LD), a revolutionary steelmaking process developed by voestalpine about 50 years ago.

In 1952, the first LD steelworks worldwide was put into operation at the Linz production site. In 2002, just in time for the works' 50<sup>th</sup> anniversary, the "Linz 2010" investment program was established. Many production plants, including the steelworks, are still located at the traditional production site in Linz. Apart from the constantly rising demand from China, the ever-increasing demand of the European automotive industry for specially treated sheet and high-tensile steel was one of the reasons why the "Linz 2010" program was launched. Two billion euros are scheduled to be invested in the modernization of the traditional production site and in the optimization of materials until 2007 in order to expand the Linz site to a leading steel competence center in Europe. So far, a continuous casting plant, a hot-dip galvanizing plant, and a coil-coating plant have been built and the company-owned power plant has been expanded. Moreover, a blast furnace was erected in the record time of a hundred days.

There are further projects on the agenda, in which SAMSON will again be involved. Control valves from SAMSON and rotary plug valves from VETEC already control many of the plants located on the Linz site. Even VOEST-ALPINE Industrieanlagenbau, a worldwide leader in continuous casting technology, equips its self-designed plants with SAMSON valves.

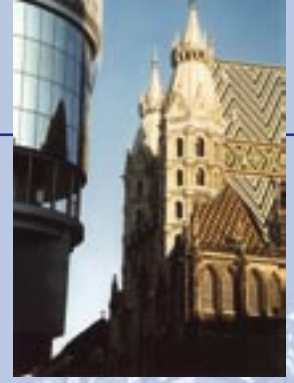

Manfred Hörst, head of SAMSON Austria, and his staff enjoy their annual meeting. · View of Vienna's St. Stephen's Cathedral

Manfred Hörst, head of SAMSON Austria. He considers them the key qualities to guarantee stability and continuity, also in the relationship with the customers. In Austria, as in all other countries where SAMSON is active, reliable and consistent customer service is the main pillar of the SAMSON philosophy.

**Ideas to change the world** – The strengths of SAMSON Austria extend far beyond providing excellent customer service; they also include detailed technical expertise and experience. Mr. Hörst and his team developed a special software to manage

district heating projects, which allows remote monitoring and maintenance of all compact stations connected to a power plant. The compact stations are installed in the buildings to be heated, including residential and public buildings, hotels etc., and replace the usual heating and hot water boilers.

**SAMSON sets an example** – A brilliant example of SAMSON's engineering expertise is the district heating project implemented in the city of Lienz, East Tyrol, which currently is Austria's largest district heating plant based on sustainable biomass and solar energy. The biomass heating plant started operation in 2001, producing 40 megawatts of environmentally friendly heat and electric power for the region. This signified a major step towards global climate protection, better air quality, and convenient heating supply. SAMSON provided the entire technology for the almost 1,000 compact stations as well as the control valves for the power plant. In 2002, the project received the Energy Globe Award in Austria, a prize to honor innovative projects in the field of sustainable energies. Every day, the city receives requests from inhabitants wishing to be connected to the system as well. As a result, 13 million euro are soon to be invested in a second power plant and the expansion of the existing supply network.

The Lienz project followed an example: The upscale Arlberg ski resort Lech has recently substituted biomass for oil—and has also switched to SAMSON equipment.

**Back to Sisi and Franz Joseph** – The Battle of Vienna not only signified the end of Muslim Ottoman attacks on Christian Europe. It also marked the birth of the Austro-Hungarian Empire. For decades, the Spanish line of the Habsburg family had held greater power, but now the Austrian line of the family became a European dynasty as well. In the course of liberation, Hungary accepted Franz Joseph's claim to inheritance of the Hungarian St. Stephan's Crown, thus extending the Habsburg's sphere of influence eastward along the river Danube. For centuries, Vienna remained the center of Habsburg power. The splendid traces are still visible today, for example in the imperial palace Hofburg that accommodated Elisabeth's private quarters and the exercise room designed specifically for her. Other popular sights include the imperial treasury and silver collection, the Spanish Riding School with its stables housing the world famous Lipizzaner-breed horses, the imperial crypt below the Capuchine Church, Schönbrunn Palace and its huge park, or the renowned Schönbrunn Zoo, the world's oldest and only baroque zoo. No



A must: exploring Vienna's old town by Fiaker, the typical horse-drawn carriage.



Visitors enjoy the beauty of the Vienna Secession building with its unique Beethoven frieze: The mural by Gustav Klimt illustrates Beethoven's *Choral Symphony, No. 9*. · The Hofburg palace complex in full splendor is home to precious objects such as the crown jewels of the Holy Roman Empire.

matter whether you like to follow in Sisi's tracks through Hofburg, promenade through the vast gardens of Schönbrunn Palace, or take a ride in the typical horse-drawn carriages through the old town's narrow streets to the imperial crypt, the glory of the six-century-long Habsburg dynasty is omnipresent throughout the entire city.

If you decide against concluding your sightseeing tour at Café Hawelka on *Dorotheergasse*, make at least sure not to miss the delicious pastries at nearby Café Demel, the former imperial purveyor to the court on *Kohlmarkt* street. Sisi was crazy about the hand-crafted sweets of the confectioner Christoph Demel but wanted to stay in shape as well. So, to burn the excess calories, the empress simply worked out on the wall bars in her own exercise room. Sisi herself could not indulge in the typical coffeehouse atmosphere but had the delicacies delivered to Hofburg. This was not due to her disliking the cafés. Rather the reason was that women were not allowed inside these refuges for intellectuals, artists, and politicians until late in the 19<sup>th</sup> century. Women across the world surely appreciate that this special tradition has been broken.

**More celebrations still to come** – The year 2006 will see even more celebrations than usual as the anniversary of another great Austrian is fast approaching: On 27 January, celebrations to honor the 250<sup>th</sup> anniversary of Wolfgang Amadeus Mozart's birth will kick off. Already at child age, the musical prodigy set out on his first tour of Europe together with his father and sister, which also took them to Frankfurt am Main. This was where two juvenile geniuses met for the first time in 1763, when the 14-year-old Johann Wolfgang von Goethe listened to a concert given by the merely seven-year-old Mozart.

Mozart lived in an apartment on *Domgasse* alley near St. Stephen's Cathedral from 1784 to 1787 and experienced his most productive period there, creating, for example the opera *The Marriage of Figaro*. If you prefer different musical talents you might want to detour to Vienna's 19<sup>th</sup> district, to Heiligenstadt, to visit the former summer residence of Ludwig van Beethoven, which is closely linked to the creation of his *Choral Symphony, No. 9*. To fully soak up the atmosphere of Beethoven's old wine-grower's house, you should sit down to enjoy a sparkling spritzer made of new white or red wine mixed with soda water in one of the typical, original inns in Heiligenstadt known as *Heurige*.

Perhaps you are also in the mood to visit SAMSON. The Vienna headquarters of the subsidiary are only a stone's throw away from the zoo, on *Amalienstraße*. A warm welcome is almost guaranteed.



Lazing in Schönbrunn Zoo, the world's oldest zoo. Up until 1778, only the imperial family was allowed to stroll through the grounds.

## In honor of the bicentenary of Adalbert Stifter and Hans Christian Andersen

### Poetry in a soft tone

**Imminent revolution** – Times were tough, not only for the writers and poets, during the *Vormärz* period leading up to the 1848 March Revolution that shook the more than thirty loosely connected Germanic states. By the late 1840s, the effects of the industrial revolution had hit Europe with full force: Tensions between the bourgeoisie, who fought to conserve its power, and the emerging class of urban workers, who lived in utter poverty and misery, rose to breaking point. The rapid population growth, unemployment, and famines added to the social disparity. At the same time,

liberal ideas surfaced and the calls for individual rights and national unity grew louder. By March 1848, Germany was a tinderbox waiting for a spark. Fueled by the revolutionary wave that washed over Europe, the tension suddenly erupted in a fierce revolt.

**Honoring the unspectacular** – Up until the 1840s, writers had mostly worked as private teachers for the important aristocratic families, writing only in their spare time. Responding to the social changes and the growing demand for popular literature, many

of them started writing for a living, trapped between their own artistic standards and the trivial taste of the public. They considered the tension-laden economic, social, and political reality inhumane and hostile. As a result, two main groups of artists emerged: those who actively voiced their discontent with the situation and those who ignored the gruesome reality in their creative work. Two representatives of the latter group were born exactly 200 years ago: the Austrian writer Adalbert Stifter and the Danish author Hans Christian Andersen. Both considered their time grim and degrading. Nevertheless, both Stifter and Andersen preferred a softer, more sensitive tone for their stories, rejecting to emphasize the spectacular. Instead, they directed their readers' attention to the small, the simple things in life. Despite these artistic similarities, Stifter and Andersen led quite different lives.

**Magician with words** – "If your novels have made you famous, your fairytales will make you immortal." Hans Christian Ørsted, a Danish scientist and friend of Andersen, was right: Who is not familiar with fairytales like *The Princess and the Pea*, *The Ugly Duckling*, or *The Emperor's New Clothes*?



Hans Christian Andersen's humble home in Odense on the island of Fyn: Like Adalbert Stifter, Andersen grew up in modest conditions but his tales brought him a small fortune and world fame.



The Little Mermaid statue in Copenhagen's harbor commemorates the enchanting tales of Hans Christian Andersen (left) · The preliminary parliament established during the 1848 March Revolution met at Frankfurt's St. Paul's Church. Adalbert Stifter (right) was an active participant in the assembly.

Andersen was born in Odense on the island of Fyn in 1805 as the son of a poor shoemaker and an exceedingly superstitious laundress. Reared in poverty, he began fighting against his nagging sense of deprivation at an early age, ambitious to earn himself respect and success. Only 14 years old, Andersen left home for Copenhagen to join the Royal Danish Theatre. He struggled to gain a footing in the theatre, but to no avail. Nevertheless, he firmly believed in his talent and focused on writing plays and poems instead. King Frederick VI grew aware of him in 1822 and paid for his education. In 1833, Andersen received a small travel stipend and set out on his first journey through Europe. In 1835, his first novel was published, bringing him his international breakthrough and the long-awaited success he had worked so hard for.

**Beyond fairy tales** – Andersen began by recrafting the old folk tales his parents had read to him. Later, the stories grew from his own deeply felt experience and fantasy, fueled by his many journeys abroad. His amazingly visual writing style brought different countries, cultures, and social classes into his readers' homes. Like Stifter, Andersen never openly criticized the social and political situation of his time. However, his stories neither were simple pieces told only for children: He spoke to adults through a mask of childishness and told children about experiences that rightly belonged in the world of grown-ups. Most works also showed strong autobiographical traits: He dealt with his humble origins, his desire to turn himself, the "ugly duckling", into a beautiful swan, and often incorporated replies to critics he felt were unfair. Andersen concluded his life as a man "rich in happy memories", as he put it. Andersen died in 1875, financially independent and world famous for his writing.

**A man ahead of his time** – Adalbert Stifter was born in Oberplan, Bohemia (now Horní Planá, Czech Republic) in 1805. The son of a simple artisan studied law in Vienna and worked as a tutor until 1846, amongst others teaching the son of the Austrian Chancellor Metternich. Despite retaining a distant political stance to the March Revolution, Stifter joined the *Nationalversammlung*, the self-appointed preliminary parliament that met in Frankfurt, in 1848. When the revolution failed, Stifter moved to Linz and was appointed supervisor of elementary schools for Upper Austria. He wrote and painted in his free time but never earned enough to make a living of his artistic work alone.

Throughout his entire lifetime, Stifter strived at implementing his humanist ideals in everyday life. He was a fervent supporter of universal schooling and education accessible to all as he considered it the only means of rooting out the rampant impoverishment. Stifter's early tales were widely acclaimed for their sensitive landscape descriptions and beautiful harmony between nature and man. The characters in his stories strived to be moral and were rather introspective, characterized by self-restraint but with a relentlessly optimistic outlook, which presented a stark contrast to the reality of the industrial revolution with its abundant technical opportunities. In his later novels, Stifter placed even greater emphasis on his visions of an ideal world, but he lost the earlier acclaim. The last years of his life were marked by deep depression, both due to his lack of success as a writer and his failed attempts at implementing his educational ideas. On 25 January 1868, Stifter slashed his neck open with a razor, dying a few days later. His works went rather unnoticed until after the First World War. Numerous celebrations to honor the bicentenaries of Stifter and Andersen are held in their respective home countries, Austria and Denmark, in 2005.



Traces of the famous fairytale writer Hans Christian Andersen can still be found all across Copenhagen: In Nyhavn, the popular new harbor, ...

## SAMSON in Denmark

# Nothing's rotten in the state of Denmark

Wherever in Europe the terrible Vikings with their horn helmets appeared at the end of the 8<sup>th</sup> century, their dreadful reputation hurried on ahead of them. By the end of the 11<sup>th</sup> century, their king, the Dane Canute the Great, had extended the Viking sphere of influence across large parts of Northern Europe. After Canute's death in 1035, Viking power in Europe temporarily subsided.

Around 1157, a second wave of invasion started almost out of nowhere. This time, the invaders gradually established permanent settlements, accepted the Christian faith, and assimilated into the peoples they had conquered, which finally marked the end of the Viking age. By then, they had established vast trade networks and laid the foundations for Scandinavia's future. Copenhagen, for example, was founded during Canute's reign. Today, Denmark's capital, together with the Swedish cities of Malmö and Lund, forms the first cross-border metropolitan area, the Øresund region.

Conveniently located in the fast-growing Øresund region, SAMSON's Danish branch was established in Birkerød, just a few kilometers north of Copenhagen in 1979. As one of SAMSON's top-performing subsidiaries, the Danish staff has a lot more to celebrate in 2005 than just the bicentenary of Hans Christian Andersen, the famous Danish writer of fairytales.



The dragon head fixed to the prow of the Viking long boats was considered an important charm, warding off the dangers of the sea.



... as well as on the night-lit H.C. Andersen's Boulevard. Andersen used to live and write in Nyhavn and gave his name to said boulevard.

PHILIPS

## Off to new shores

**"From the wrath of the Northmen deliver us, O Lord!"** – Around the end of the 8<sup>th</sup> century, heathen hordes from the north started to launch onslaughts on the Christian world, spreading fear and terror among the threatened population, as expressed in this old English prayer. The Vikings, or Norsemen as they were also known, left Norway, Sweden, and Denmark in a quest for wealth and power, attacking, looting, and burning churches and monasteries along the European coasts. Nevertheless, the fascination with these rough raiders continues well into our time. The legend of the ungodly adventurers and merciless warriors, steeled in the harsh environment of the North who cart off anything of value, has obscured the view of Viking achievements for several centuries. Today's research, however, focuses more on pointing out the extraordinary, awe-inspiring talent of the Norsemen when it came to navigation and commerce.

**The beginnings** – Alcuin (circa 735 to 804), an influential Anglo-Saxon theologian and scholar serving at Emperor Charlemagne's court, greatly assisted in branding the Vikings. Being a former monk, Alcuin followed their raiding the island monastery of Lindisfarne off the northeastern coast of England in 793 and reported it to Rome, instantly raising attention among the top political and clerical ranks. Alcuin also set the tone for future chronicles of the Viking raiders, stigmatizing them as the incarnation of Evil, but also turning them into God's just punishment well suited to save the human soul. Nevertheless, Charlemagne had several naval bases constructed along the coastline threatened by the vicious Vikings and ordered fleets to patrol the coastal waters.

**Emerging out of nowhere** – The greatest menace to the population of Lindisfarne—as to most cities under Viking attack—was that the raiders for the first time

advanced from the open sea. This made their attacks entirely unpredictable, particularly if we keep in mind that open-sea assaults were considered impossible then due to the way ships were commonly constructed in Central and Southern Europe at that time. Islands like Lindisfarne, in particular, were thought to be unconquerable from the sea. Apart from their silent, unexpected approach, the raiders retreated just as rapidly as they had arrived, leaving behind nothing but death and devastation.

**At home at sea** – Without any doubt, no-one at that time knew the vast blue expanses of the North Sea, the Baltic Sea, the Mediterranean, and the Atlantic Ocean better than the Vikings did. Back home, the sailors had learned to live on and with the water while fishing or competing in their popular sports contests. It is thus no wonder that the Vikings brought



Hamlet's castle in Helsingør, better known as Kronborg Castle, is a must for any Shakespeare enthusiast. The tragedy is said to be set in the Dutch-renaissance-style castle.



The world-renowned Carlsberg brewery was founded just outside Copenhagen almost 150 years ago. Advertised as “probably the best beer in the world”, Carlsberg is one of Denmark’s major exports.

about extremely talented and agile warriors as well as gifted, fearless seafarers. They perfectly maneuvered their typical open longboats with square sails driven by up to 60 men with oars. The vessels were sturdy enough to handle the stormy seas of the North Atlantic, yet narrow and light enough to silently glide through the shallower waters of rivers and the coast. Viking tactics involved quickly approaching the target from the open sea and retreating just as quickly back to the open waters. In addition, no construction plans existed for their ships, neither for the long warships,

nor for the Viking merchant ships known as “knorr.” How to build these exceptionally versatile vessels was a well-kept secret and part of the oral tradition passed down from generation to generation. Most of the time, if at all, the slow, heavy, and ponderous ships of the attacked confined them to doing nothing more than fuming and watching the Vikings make a clean getaway to the open sea.

**Warriors settle down** – In the early days of their journeys, the Vikings always returned home after their raids to winter in their own countries. Later,

they started establishing permanent settlements in the conquered areas and gradually stopped plundering and destroying. Instead, they imposed a tribute on the occupied population known as “Danegeld”, which would spare the raided from further furious attacks.

**Skilled merchants** – Copenhagen—Denmark’s metropolis and one of the most beautiful European capitals—was founded during the reign of Canute the Great around 1000 AD. Its importance as a center for commerce and trade continues to be reflected in the city’s Danish name, København, a corruption of the original designation, Købmandshavn, meaning “merchants’ harbor.” Apart from being ruthless warriors and skillful sailors, the Vikings displayed an extraordinary talent for commerce and trade, establishing relations nearly all across the world. Their trade and knowledge networks stretched from the Orient to North America, the most important goods being animal skins and slaves.

Canute’s death in 1035 signified the end of the great Viking empire. Nevertheless, their almost 300-year-long reign left a lasting mark on Europe’s political, commercial, and cultural map and also furthered Denmark’s, Norway’s, and Sweden’s integration into the customs of the continent. The advancing conversion to Christianity played an important



Denmark, the smallest Scandinavian country, is a country of islands. It is composed of the Jutland peninsula and over 480 smaller and larger islands: a true paradise for sailors.





Today, sheep graze on the old Viking settlement and graveyard on the Lindholm Høje chalk hill, one of the most beautiful Viking monuments.

role in this process, at least as important as the Viking's settling down. Their setting-up home in the occupied regions caused the invaders to integrate with the peoples they had conquered and governed, making them forget some of their old customs and habits. It was around 965 during the reign of Harold Bluetooth—son of Gorm the Old, the actual founder of the state of Denmark—that Denmark officially converted to Christianity. Harold largely relied on the Church in his efforts to unify previously warring tribes from Denmark, Norway, and Sweden, thus paving the way for political stability in Denmark as well as providing a sound basis for economic growth and cross-border trade with the neighboring countries. Allegedly, Harold's success at unification was also the reason why his name was chosen for the Bluetooth short-range wireless connectivity standard, which aims at unifying different technologies like computers and mobile phones. Not surprisingly, networking and the exchange with other countries continue to be of great importance to Denmark's economy.

**Danish economy today** – Exports as the major economic factor account for two thirds of Denmark's GDP, the most important trade partners being Germany, Sweden, Great Britain, the US, Japan, and Norway. To ensure the barrier-free exchange of goods and services across borders, Denmark has joined various multinational business organizations including the EU, OECD, and WTO.

Over the past decades, the composition of Denmark's exports has changed radically, with industrial goods, such as machinery and instruments, supplanting agricultural products as the country's main exports. And even though 65 % of Denmark's area continue to be used for agricultural production, only 4 % of the Danish employees still work in this sector. The formerly agriculture-dominated country has been trans-



Cool Sorption uses SAMSON's self-operated regulators, control valves, positioners, and butterfly valves in its compact vapor recovery units.

## Every small amount counts

Every time liquid petrochemicals are pumped from one tank to another, a mixture of air and hydrocarbon vapors escapes. The loss—only one thousandth of the handled product at each loading point—appears to be relatively small. However, keeping in mind the enormous amounts of liquid petrochemicals handled worldwide, the small losses rapidly add up to a considerable total. As many as 250 million liters of these fuels are recovered each year by the vapor recovery units (VRUs) developed by the Danish company Cool Sorption A/S, a frontrunner in the field of emission abatement technologies for volatile organic compounds. The recuperated hydrocarbons would easily suffice to keep 125,000 cars running 20,000 km each.

Since its foundation in 1982, Cool Sorption has supplied almost 200 VRUs to nearly all oil companies across the world for various kinds of installations: The escaping gasoline or crude oil vapor is routed from the loading points through a collection system to the vapor recovery unit where the hydrocarbon is recovered by absorbing it in activated carbon, which is then regenerated under vacuum. The remaining clean air is emitted back to the atmosphere. Apart from the economic aspect, the recovery of hydrocarbons is of significant importance to the environment, both locally for the people at and near the loading points as well as on a global scale as hydrocarbons are a major greenhouse gas.

Over 80 % of Cool Sorption's VRUs are connected online with the headquarters in Denmark for maximum reliability and easy assistance in case of malfunction. No wonder that the overall availability of the VRUs is greater than 98 %.

From the very beginning, the vast majority of Cool Sorption's VRUs were fitted with control valves from SAMSON, forming a long-standing partnership. The most frequently used models include the Type 3241 Control Valves, Type 3331 Butterfly Valves, Type 42-36 and Type 4/2231 Self-operated Regulators, and even Type 3281 Steam-converting Valves.



Northern Jutland is not just a popular holiday destination for nature lovers who enjoy the dunes along the Limfjord sound, but also one of the fastest-growing business areas in Scandinavia.

formed into a prosperous industrial nation, making Denmark one of the world's most attractive sites for business and foreign investment thanks to favorable tax and labor costs.

Hamlet, Shakespeare's unfortunate Prince of Denmark who, in his time, used to be rather appalled by the state of affairs in his home country, would have little reason to complain now. The well-known concern, "Something is rotten in the state of Denmark", uttered by Hamlet's kinsman Marcellus in the first act of Shakespeare's tragedy can be considered unfounded in view of Denmark's current situation.

**Strong export orientation** – The importance of exports to Denmark's economy has also shaped everyday operations at SAMSON's Danish subsidiary, SAMSON REGULERINGSTEKNIK A/S. Its main customers including ABB,

Alfa Laval, Arla Foods, FLSmidth, GEA Niro Inc., HALDOR TOPSOE, Invensys APV, and Novo Nordisk also show a strong export orientation. As a result, the operations of SAMSON Denmark are less centered around the relatively irregular project business to be processed in stages. Rather, the main focus for the subsidiary lies with conducting regular business on a day-to-day basis, which nevertheless requires great flexibility. To be competitive, the stocks of SAMSON Denmark are well equipped, keeping material worth 1.6 million euros ready at hand. Over 30,000 device versions can be assembled from valves, actuators, and positioners at short notice.

**Customer relationship management of a different kind** – In line with the long-standing continuity that customers rely on, personal contact with the

customer and the staff as well as the exchange of technical ideas are still high on the agenda at SAMSON Denmark.

**Hands-on experience** – "Twelve eyes see more than two", according to an old Danish saying that wishes to express that practical experience is indispensable when dealing with specific tasks at hand. Jørn Møller, head of SAMSON's Danish subsidiary since 1988, is a fervent supporter of the idea that hands-on experience is much more lasting than any knowledge gained from theory and abstraction. This is why Mr. Møller has regularly invited SAMSON's Danish customers to join him on a visit to the main SAMSON AG, VETEC, and Pfeiffer sites in Germany over the past 15 years, allowing the guests to experience firsthand how the people at SAMSON and its associated compa-

## Danish mustard-dill sauce

- 1 bunch of dill
- 2 tablespoons of sugar
- 2 egg yolks
- 2 tablespoons of lemon juice
- 6 teaspoons of medium-hot mustard
- 6 teaspoons of honey
- 2 tablespoons of cream



Chop the dill and mix all ingredients in a bowl. Spice with salt and pepper and cool the sauce in the fridge. Serve with gravad lax (cold-cured salmon) or other fish dishes.



Team work is highly important to Jørn Møller (fifth from the right), head of SAMSON Denmark: The 2004 sales meeting was held on a sailing ship. · Over 30,000 versions can be assembled in Birkerød at short notice. · Jesper Petersen, a member of staff, starts up a control valve in a thermal power plant.

nies think, work, and produce. The most valuable impressions that the visitors take home are usually those gathered at the test benches and in the quality assurance department. Each visit is concluded by exchanging ideas about technical developments and opportunities, which can be done on a much broader basis thanks to the experience gained on site. Word quickly got round that the tours organized by Mr. Møller are far more than interesting, making it harder each time for the customers to snatch one of the few, much sought-after spaces.

**Succeeding as a team** – “If the others are fine, I am fine too”, is the second important motto that Mr. Møller likes to follow. The continuing growth of SAMSON Denmark over the past years has proved him right and helped his subsidiary become one of the most successful branches of the SAMSON Group. Surely, the excellent cooperation of the team, i.e. the eleven members of staff at the Birkerød headquarters as well as the six employees in the Jutland office, has contributed greatly to this success. SAMSON Denmark can pride itself on the excellent technical and engineering expertise of its staff. In addition, a full range of products can be supplied for any process requiring steam as the energy source.

**Evolution and growth** – The headquarters of SAMSON REGULERINGSTEKNIK A/S in Birkerød were established in 1979. Only five years later, SAMSON Denmark acquired its own facilities, which continue to be used today. Thanks to the site’s favorable location north of Copenhagen at the heart of the fast-growing Øresund region and the easy access to major transport hubs, Birkerød has proven to be the ideal choice. In 1985, the subsidiary’s office on the Jutland peninsula was opened.

Recently, the office has been expanded and new office, storage, and training facilities have been acquired in the city of Randers. It was thus no wonder that SAMSON Denmark proudly celebrated its 25<sup>th</sup> anniversary last year, resting assured that the subsidiary is excellently prepared for any challenge that the future may hold.

**Reasons to celebrate** – In contrast to Austria, where the celebrations of the 2005 Stifter Year will blend right into the festive events of the 2006 Mozart Year, Denmark will probably take a short rest from celebrating, at least when it comes to staging official anniversaries and jubilees. The event-packed year 2005 will be concluded on 6 December, on the exact day that the popular writer Hans Christian Andersen finally returned to his home town of Odense on the island of Fyn in 1867 to be proclaimed honorary citizen.



Egeskov Castle on Fyn, the island where Hans Christian Andersen was born, figures among Europe’s best-preserved renaissance castles.



SAMSON's compact electric actuators include fail-safe action and torque-dependent switch-off.

## Powerful yet sensitive Electric actuators from SAMSON

**SAMSON can provide the right actuator, whether electric or pneumatic, for any application. In industrial plants, pneumatic actuators are used most frequently to drive the installed valves. Thanks to their design, the actuators are explosion protected and include a fail-safe function thrown in virtually free of charge, which opens or closes the connected valves if the supply air fails or any other fault occurs. In addition, they are cost-effective, rugged, reliable, and maintenance free due to their simple design.**

**In such areas, however, where the supply of compressed air is not required, e.g. in supply engineering, power plant applications, and many industrial plants, electric actuators are the prime choice. SAMSON provides a full range of electric actuators for the lower and medium thrust ranges, both with and without spring mechanism for the fail-safe function.**

**The actuators are tailored to meet the specific requirements of the different applications, providing innovative, custom solutions.**

**Currently, SAMSON produces over 40,000 actuators per year and is planning to expand the product range to include actuators for lower and higher demands as well.**



SAMSON's controller with electric actuator is designed for DHW applications in instantaneous heating systems.



State-of-the-art control: SAMSON's electric actuator with digital positioner uses neural network technology.



SAMSON has a patent for the functional principle of torque-dependent switch-off using planetary gears.

## Actuators that never run out of breath

**Compact yet powerful** – SAMSON uses self-locking synchronous motors that run at a constant speed for its electric actuators. Merely the strongest electric actuators are equipped with an asynchronous motor that requires an electromagnetic brake.

In general, the lower gearing levels are executed as simple helical gears, while at least the higher levels are planetary gears. The torque acting on the ring gear of the planetary gear is compensated by tangentially arranged compression springs. If the permissible torque is exceeded, the springs are compressed and the motor is switched off: an innovative, compact, and smooth solution that functions reliably in both senses of rotation.

In small actuators without fail-safe function, the rotary motion is cost-effectively converted into a linear motion by a worm gear. For medium-sized actuators, a special lever is used. And in large actuators with a high efficiency exceeding 90 percent, the rotation is converted into a linear travel motion by a recirculating ball screw.

**Safe in any condition** – In actuators with fail-safe action, the motor is coupled to the gearing over a magnetic clutch with integrated centrifugal brake. In case of a fault, the gearing is uncoupled from the self-locking motor and moves to the predetermined fail-safe position using the force of a pretensioned compression or torsion spring. The centrifugal brake ensures that the permissible stroking or closing speed of the valve is not exceeded.

SAMSON has taken out patents for many of the specific technical solutions included in the compact gearing design of the electric actuators with torque-dependent switch-off and fail-safe action.

**State-of-the-art positioners** – Although the electric actuators do not necessarily require positioners for

exact positioning, all actuators can soon be equipped with a digital positioner suitable for an input signal of 0 to 10 V, which is commonly used in heating, ventilation, and air-conditioning applications. Automatic start-up, adaptation of characteristic and span, split-range operation as well as online diagnostics, for example, are common, state-of-the-art positioner functions. The principle of operation of the positioners for integration into large actuators has even been copied from the human brain: The positioner output is determined on the basis of an artificial neural network.

**Integrated controllers** – SAMSON has identified promising market opportunities for actuators with integrated PI or PID controllers. These combination devices are particularly suitable to control domestic hot water (DHW) applications in instantaneous water heating systems or outdoor temperature compensated heating applications in small and medium-sized residential units connected to a local or district heating network. A convenient, demand-driven hot water supply can be guaranteed even without a circulation pipe by adding a flow meter or flow switch. Connecting a room panel with a temperature sensor to the integrated controller for heating applications ensures ease of operation and the right room temperatures at all times.

A major factor contributing to the success of the SAMSON electric actuators is that they form a perfect unit with SAMSON's valves. Effortless start-up and an excellent control behavior are guaranteed by simple adaptation—using a force-locking connection for small nominal valve sizes—as well as matching travels and transit times.



If emissions are kept at bay, agriculture and industry can coexist.

# Sealed for life Emission control using the bellows

The threats to people and the environment posed by harmful substances still figure among the most pressing problems of our time. Consequently, emission control is now high on the political agenda in most industrialized countries.

Far-reaching regulations such as the US Clean Air Act or Germany's TA-Luft were implemented to safeguard air quality in the long run. As part of a United Nations initiative, the leading industrialized nations have reached a global agreement, committing themselves to protect the environment for the next generations and to considerably reduce greenhouse gas emissions. BASF, for example, plans to cut back greenhouse gas emissions from its global chemicals operations by 40 percent based on the 2002 figures.

In industrial plants, however, harmful substances are not only emitted from defined sources such as chimneys: A large proportion also comes from diffuse sources spread across the plant area including flanges, valve shafts, and valve stem seals. Defined-source emissions can drastically be reduced by optimizing procedures and processes; emissions from stem seals can be cut back by using SAMSON's bellows-sealed control valves.

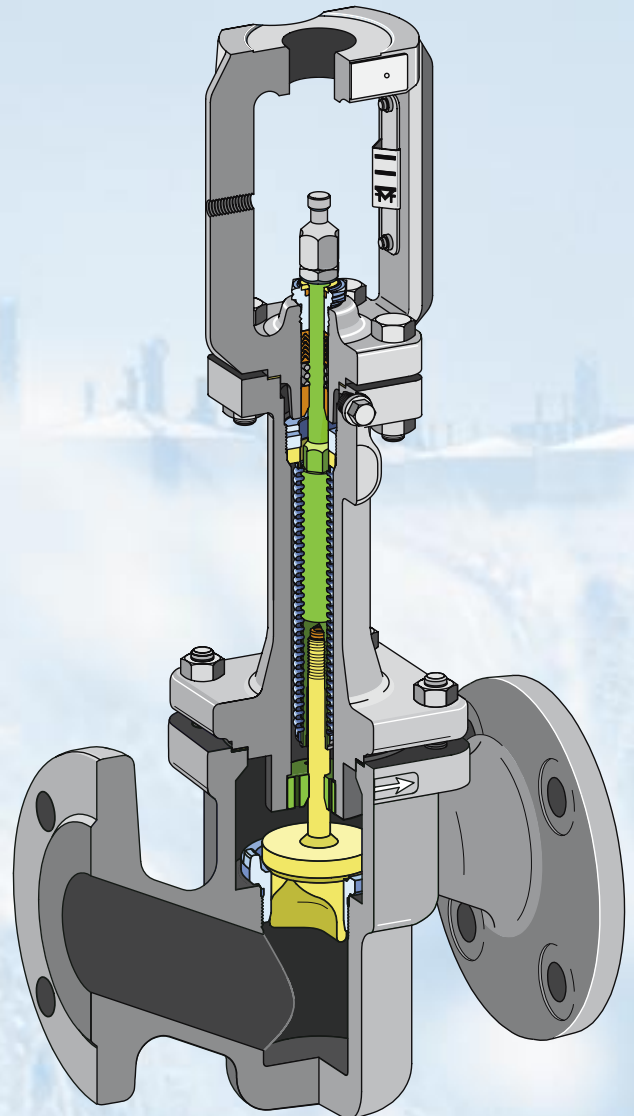

A standard forged valve from SAMSON with bellows seal and backup stuffing box.



A typical SAMSON valve trim: threaded seat with seat-guided V-port plug and bellows seal.



SAMSON manufactures its own standard bellows from stainless metal sheets on self-developed machines.

## Efficiently combating fugitive emissions

**Never absolutely leak-tight** – Sealing integrity is not a case of black or white that can be exactly defined as “tight” or “leaking.” The theoretical state of 100 % emission containment cannot be achieved in practice. The SAMSON bellows seal, for example, still has a very low leakage rate, which is hardly traceable by extensive helium leak testing. The weak point of the bellows seal is the detachable connection between the bellows and the valve body. At this point, a small number of gas molecules can still escape, but never exceeding 0.32 cubic centimeters per year at a differential pressure of 1 bar. The leakage rate for a new standard packing for example, is 10,000 times higher. This is no surprise if we keep in mind that the packing must seal off the space at the plug stem, stop leakage between the packing and the stuffing box wall as well as prevent diffusion through the packing material itself.

**Difficulties posed by pressure and temperature** – The sealing behavior of the valve packing is influenced by numerous parameters. A major factor is its susceptibility to pressure and temperature, which is negligibly small in the case of the bellows. While the bellows still has an excellent sealing performance at operating temperatures between  $-200\text{ }^{\circ}\text{C}$  and  $+450\text{ }^{\circ}\text{C}$ , the standard packing made of PTFE and similar compounds gives up already at temperatures below  $-10\text{ }^{\circ}\text{C}$  and exceeding  $+250\text{ }^{\circ}\text{C}$ . The application range of a standard packing can be extended to that of a bellows by using an insulating section, which keeps the high-temperature process medium away from the packing. Nevertheless, the packing will never achieve the reliability of a bellows.

**Ageing of packings** – Apart from being unaffected by pressure and operating temperature, the bellows seals tightly without requiring maintenance while the

packing is subject to wear due to increased friction on the plug stem induced by the ageing of the applied lubricants. The packing needs to be serviced or even replaced periodically to keep the fugitive emissions rate at the initial value. Simply retightening the packing does indeed reduce the leakage rate, but it also causes friction to rise, which in turn heightens the packing’s susceptibility to wear and affects the valve’s control response.

As a result, certificates issued by TÜV or other certified bodies that confirm the equivalence of the packing to the bellows when it comes to sealing ability are to be judged critically. Such documents merely certify that the leakage rate of the system during the test remained below  $10^{-5}$  mbar l/s. While great effort is required to achieve such results for a packing, a bellows seal can accomplish leakage rates below  $10^{-8}$  mbar l/s without any difficulty.

The sealing quality of the SAMSON bellows seal becomes most obvious when taking into account that the 1,000-times-higher leakage rate of the certified packing still is 100 times smaller than the amount that escapes through a hole with the diameter of a hair. In more precise terms: The leakage rate of 1 mbar l/s corresponds to a gas flow of 0.001 l/s into an evacuated container or, in other words, causes an initial pressure change of 1 mbar/s in an evacuated container with a volume of 1 liter.

**In-house production** – Did you know that the metal bellows was invented by Hermann Sandvoss, the founder of SAMSON, who had his innovation patented in 1909? No wonder that SAMSON trusts in its vast bellows expertise and manufactures its own standard bellows of stainless steel, copper, and Hastelloy sheets on machines specifically developed by SAMSON engineers.



Table Mountain with its unique flat top dominates the cityscape of Capetown, where SAMSON founded a new subsidiary in 2005.

## Financial year 2004/2005 **SAMSON** continues its success story

For SAMSON, the 2004/2005 financial year was again marked by expansion. Not only the Jutland sales office in Denmark has been expanded, the SAMSON sales network also grew in other parts of the world: New valve service centers were opened in Egypt and Qatar, a new subsidiary was established in South Africa, and a new representative was added in Pakistan.

The chemical industry in Qatar has been ordering large quantities of SAMSON control equipment through German engineering companies for years; by extending the sales network in the Middle East and in South Africa, the SAMSON Group is paving the way for a successful future. The Group has taken on the challenge of fully exploiting the actual market opportunities in both regions, although SAMSON products have already been supplied through European plant engineers.

Despite the continuing low that the German domestic market is experiencing, the SAMSON Group managed to increase its sales by almost eight percent in 2004/2005 compared to the previous year, generating consolidated sales of EUR 327 million—a clear indication that the SAMSON strategy of being close at hand for customers across the world is spot-on.

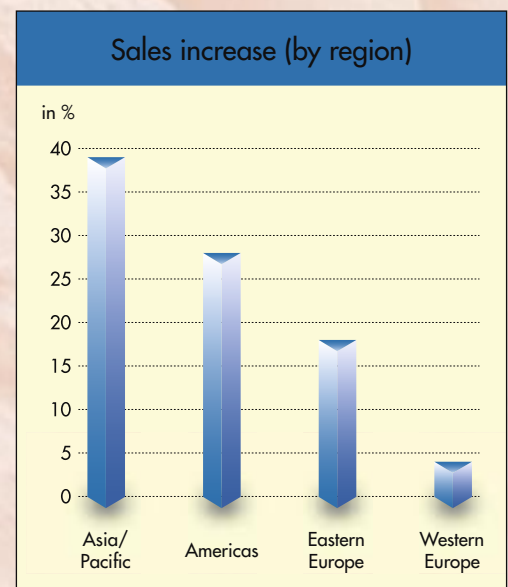
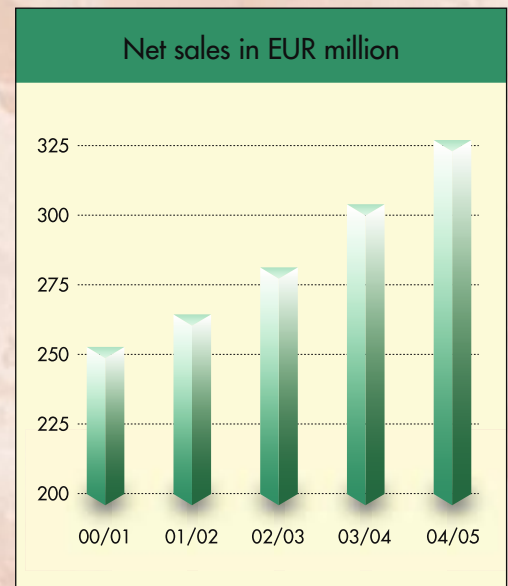





In fall 2005, the valve service center will officially be opened in Badr City. From there, SAMSON's products can conveniently be supplied to the customers in North Africa and the Middle East. Mr. Vinod P. Joshi (left), head of the Egyptian subsidiary, and the service engineer Mr. Ehab H. Edward.

## Outperforming the global competition

**Asia in the lead again** – With an average increase in turnover of 39 percent, the Asian markets managed to defend the number-one spot in SAMSON's corporate ranking of growth markets in the financial year 2004/2005. East Asia was the first runner-up among the regions with the highest turnover. With the exception of the Japanese subsidiary, which recorded a huge plus in sales in the project business in the previous financial year, all subsidiaries achieved two-figure growth percentages. China turned out to be the top foreign market, with the subsidiary upping its number of placed orders and with a 69 percent increase in turnover. With 52 percent, the Indian subsidiary also boosted its sales considerably.

A new SAMSON representative, INNOVATIVE AUTOMATION & ENGINEERING PVT. Ltd., was found in Lahore, Pakistan, near the Indian border, where the food and textiles industries are centered.

**Africa making up ground** – Over the past financial year, SAMSON has also been present on the growing markets in Africa. In South Africa, a new subsidiary, MONITOR-SAMSON CONTROLS (PTY) Ltd., was established. Apart from supplying SAMSON's currently most important customers in the textile and food industries, the new branch is expected to provide products and services to the chemical industry as well.

**SAMSON Middle East on the jump** – A challenging project has been launched southeast of Riyadh, right in the middle of the Saudi Arabian Al Kharj desert, one of the hottest places on earth. Almost like a mirage, metal towers reaching 15 meters in height jut right out of the hot sand. Yet, the cooling towers of the world's largest integrated dairy farm operated by Al Safi-Danone are not just an illusion. The farm comprises 35 square kilometers and more than 29,000 cows ensure a daily production of around

500,000 liters of fresh milk, an achievement recognized even as a Guinness World Record. The farm's production comprises over 75 dairy products, which are reliably handled by SAMSON's food-processing valves.

To move even closer to customers in the Middle East, SAMSON has established a new valve service center in Badr City near Cairo, Egypt. The conveniently located center is intended to supply the representatives in Egypt. In addition, it assists the representatives in the nearby countries including Libya, Jordan, Lebanon, Syria, Iran, Kuwait, Saudi Arabia, Bahrain, Qatar, UAE, Oman, Yemen, and Sudan in all technical matters and ensures a quick delivery of SAMSON equipment. When the new center is officially opened in October, SAMSON is the only valve manufacturer in the area capable of assembling equipment on site at short notice. The new subsidiary is headed by Mr. Vinod P. Joshi, who has been active for SAMSON in the region for years.

Operations in Qatar have been expanded as well: QATAR MODERN INSTRUMENTS & CONTROLS Co., SAMSON's long-standing representative in the emirate, has also established a new valve service center with support from the Frankfurt headquarters. The center will cater to the main customers in the oil and gas industry.

**Close to the home base** – Western Europe continues to be the region with the highest sales. Registering a plus in turnover of approximately 16 percent, both the Iberian and the Dutch market performed particularly well. In Eastern Europe, the highest growth rates were achieved by Hungary and Russia with 28 and 21 percent respectively.



All key business processes are steered from the SAMSON headquarters in Frankfurt am Main.

## IFS Applications New corporate software at SAMSON

The advancing globalization of markets, which for some companies is accompanied by increased customer demands concerning product availability, service, and price, is the foremost reason for every company to orient its own organizational structures towards the changed conditions. SAMSON AG and its sales network have been expanding continually over the past years. The conditions and requirements of new markets that have been opened up call for constant adaptation within the company. Since the beginning of 2005, worldwide business processes have been supported by a new enterprise software, IFS Applications. The software package supplied by IFS, a leading provider of business solutions from Sweden, is designed in modules that can be tailored to individual requirements, which makes the program exceptionally flexible. The new business solution replaces the production-centered SILINE software successfully applied at SAMSON over the past years, paving the way for standardized company-wide communication on a worldwide scale. Yet, despite the obvious benefits that the system brings, it still posed a challenge on its launch.



SAMSON's products are delivered all over the world. The new corporate software contributes to the fast and flexible delivery.



SAMSON staff at work in the logistics center. Parts are produced independently of customer orders, kept in stock, and assembled on demand to respond to customer orders as flexibly as possible. The new corporate software supports the parts' management.

## An added value for our customers

**How it all began** – The fact that the SAMSON AG sales network has been expanding on every continent for years emphasized the priority of the matter. This continual expansion and the arising era of information technology providing worldwide access to increasing amounts of information and the standardization of business processes at all subsidiaries entailed the need to re-organize the existing software solution. In 1999, SAMSON began to deal with the implications of introducing an appropriate software solution tailored to the needs of the company.

All SAMSON subsidiaries and sales offices worldwide must have access to key information in real time to provide better customer support in future. The main objective is to react faster to customer requests and secure the standard of quality in the company. SAMSON AG decided in favor of the IFS Applications software from the Swedish software specialist who also supplied other software solutions in use at SAMSON. The additional benefit of this choice was that it allowed making full use of the synergy effects.

**Teamwork needed** – The introduction of any new corporate software is accompanied by the revision of existing work processes as they need to be adapted to the new system. To achieve the best results, employees from all areas, such as sales, after-sales service, and R&D, worked together with external consultants from IFS in project teams. The objective of this approach was to pool specialized knowledge from each department and to integrate it directly into the implementation of the new system.

**Article code as the key** – A major issue during implementation was the revision of the existing coding

system for SAMSON products. The aim was to keep the type designation and to define the characteristics of each product in clear properties. A unique article code is assigned to every SAMSON product, clearly identifying it.

The smooth transition from the old to the new system also required an extensive training concept to be drawn up for the headquarters and for all subsidiaries. Shortly before the new system was launched, a large number of staff had to be made familiar with the new system. Key users were trained who then took on the task of instructing their colleagues in their own departments.

After a development phase lasting several years, IFS Applications was introduced in steps. In November 2004, the after-sales service department was the first to put the system into practice. In January 2005, it was turn for all sales operations to be linked up with the system. An ongoing process: In the run-up to the launch, the system was put to the test by key users using real customer orders. The module for the R&D department is to follow in late 2005.

**Inside and out** – Apart from IFS Applications, more precisely termed ERP (Enterprise Resource Planning), the IFS Sales and Marketing module was introduced simultaneously for customer relationship management. This tool assists project work, allowing information to be exchanged on a worldwide basis. The time required from the concept to implementation stage took approximately two years. Another project team was also formed to implement the requirements of all departments involved together with the software company.

The universal tie linking the subsidiaries outside Germany to the new software platform is the next challenge awaiting SAMSON.

# SAMSON worldwide



**SAMSON**

SAMSON AG · MESS- UND REGELTECHNIK · Weismüllerstraße 3 · 60314 Frankfurt am Main · Germany  
Phone: +49 69 4009-0 · Fax: +49 69 4009-1507 · E-mail: [samson@samson.de](mailto:samson@samson.de) · Internet: <http://www.samson.de>