

MOUNTING AND OPERATING INSTRUCTIONS



EB 8074 EN

Translation of original instructions



Type 3296 Valve · ANSI version

In combination with an actuator,
e.g. a Type 3271 or Type 3277 Pneumatic Actuator

Edition May 2021



Note on these mounting and operating instructions

These mounting and operating instructions assist you in mounting and operating the device safely. The instructions are binding for handling SAMSON devices. The images shown in these instructions are for illustration purposes only. The actual product may vary.

- For the safe and proper use of these instructions, read them carefully and keep them for later reference.
- If you have any questions about these instructions, contact SAMSON's After-sales Service (aftersaleservice@samsongroup.com).



Documents relating to the device, such as the mounting and operating instructions, are available on our website at www.samsongroup.com > **Service & Support > Downloads > Documentation.**

Definition of signal words

DANGER

Hazardous situations which, if not avoided, will result in death or serious injury

WARNING

Hazardous situations which, if not avoided, could result in death or serious injury

NOTICE

Property damage message or malfunction

Note

Additional information

Tip

Recommended action

1	Safety instructions and measures	1-1
1.1	Notes on possible severe personal injury	1-5
1.2	Notes on possible personal injury	1-5
1.3	Notes on possible property damage	1-8
1.4	Warnings on the device.....	1-9
2	Markings on the device	2-1
2.1	Valve nameplate	2-1
2.2	Actuator nameplate.....	2-2
2.3	Material identification number	2-2
2.4	Label when an adjustable packing is installed	2-2
3	Design and principle of operation	3-1
3.1	Fail-safe positions	3-3
3.2	Versions	3-3
3.3	Additional fittings.....	3-3
3.4	Valve accessories	3-4
3.5	Technical data	3-4
4	Shipment and on-site transport	4-1
4.1	Accepting the delivered goods	4-1
4.2	Removing the packaging from the valve.....	4-1
4.3	Transporting and lifting the valve.....	4-1
4.3.1	Transporting the valve	4-3
4.3.2	Lifting the valve.....	4-3
4.4	Storing the valve	4-5
5	Installation	5-1
5.1	Installation conditions	5-1
5.2	Preparation for installation.....	5-3
5.3	Mounting the device.....	5-4
5.3.1	Mounting the external anti-rotation fixture.....	5-4
5.3.2	Mounting the actuator onto the valve	5-14
5.3.3	Installing the valve into the pipeline	5-16
5.4	Testing the installed valve.....	5-17
5.4.1	Leak test	5-18
5.4.2	Travel motion	5-19
5.4.3	Fail-safe position.....	5-19
5.4.4	Pressure test.....	5-19

Contents

6	Start-up	6-1
7	Operation	7-1
7.1	Normal operation	7-1
7.2	Manual operation	7-2
8	Malfunctions	8-1
8.1	Troubleshooting	8-1
8.2	Emergency action	8-3
9	Servicing	9-1
9.1	Periodic testing	9-3
9.2	Preparing the valve for service work	9-5
9.3	Installing the valve after service work.....	9-5
9.4	Service work.....	9-6
9.4.1	Checking facings	9-6
9.4.2	Replacing the gaskets	9-6
9.4.3	Replacing the packing	9-10
9.4.4	Replacing the seat and plug.....	9-12
9.4.5	Determining the number of gaskets required.....	9-16
9.4.6	Tightening the body nuts.....	9-19
9.5	Ordering spare parts and operating supplies	9-20
10	Decommissioning	10-1
11	Removal	11-1
11.1	Removing the valve from the pipeline.....	11-2
11.2	Removing the actuator from the valve	11-2
12	Repairs	12-1
12.1	Returning devices to SAMSON	12-1
13	Disposal	13-1
14	Certificates	14-1
15	Annex	15-1
15.1	Tightening torques, lubricants and tools	15-1
15.2	Spare parts	15-1
15.3	After-sales service	15-6

1 Safety instructions and measures

Intended use

The SAMSON Type 3296 Angle Valve in combination with an actuator (e.g. Type 3271 or Type 3277 Pneumatic Actuator) is designed to regulate the flow rate, pressure or temperature of liquids, gases or vapors. The valve with its actuator is designed to operate under exactly defined conditions (e.g. operating pressure, process medium, temperature). Therefore, operators must ensure that the control valve is only used in operating conditions that meet the specifications used for sizing the valve at the ordering stage. In case operators intend to use the control valve in other applications or conditions than specified, contact SAMSON.

SAMSON does not assume any liability for damage resulting from the failure to use the device for its intended purpose or for damage caused by external forces or any other external factors.

➔ Refer to the technical data and nameplate for limits and fields of application as well as possible uses.

Reasonably foreseeable misuse

The control valve is not suitable for the following applications:

- Use outside the limits defined during sizing and by the technical data
- Use outside the limits defined by the valve accessories connected to the valve

Furthermore, the following activities do not comply with the intended use:

- Use of non-original spare parts
- Performing service and repair work not described

Qualifications of operating personnel

The control valve must be mounted, started up, serviced and repaired by fully trained and qualified personnel only; the accepted industry codes and practices must be observed. According to these mounting and operating instructions, trained personnel refers to individuals who are able to judge the work they are assigned to and recognize possible hazards due to their specialized training, their knowledge and experience as well as their knowledge of the applicable standards.

Welding operations must only be performed by personnel who has the necessary qualification to perform the applied welding procedure and handle the materials used.

Explosion-protected versions of this device must be operated only by personnel who has undergone special training or instructions or who is authorized to work on explosion-protected devices in hazardous areas.

Safety instructions and measures

The operating personnel must be specially trained for the correct and safe handling of oxygen when valves are used for oxygen service.

Personal protective equipment

We recommend checking the hazards posed by the process medium being used (e.g. ► GESTIS (CLP) hazardous substances database). Depending on the process medium and/or the activity, the protective equipment required includes:

- Protective clothing, gloves, eye protection and respiratory protection in applications with hot, cold and/or corrosive media
 - Wear hearing protection when working near the valve
 - Hard hat
 - Safety harness when working at height
 - Safety footwear, ESD (electrostatic discharge) footwear, if necessary
- ➔ Check with the plant operator for details on further protective equipment.

Revisions and other modifications

Revisions, conversions or other modifications of the product are not authorized by SAMSON. They are performed at the user's own risk and may lead to safety hazards, for example. Furthermore, the product may no longer meet the requirements for its intended use.

Safety features

The fail-safe position of the control valve upon air supply or control signal failure depends on the actuator used (see associated actuator documentation). When the valve is combined with a SAMSON Type 3271 or Type 3277 Pneumatic Actuator, the valve moves to a certain fail-safe position (see the 'Design and principle of operation' section) upon supply air or control signal failure. The fail-safe action of the actuator is the same as its direction of action and is specified on the nameplate of SAMSON actuators.

Warning against residual hazards

To avoid personal injury or property damage, plant operators and operating personnel must prevent hazards that could be caused in the control valve by the process medium, the operating pressure, the signal pressure or by moving parts by taking appropriate precautions. Plant operators and operating personnel must observe all hazard statements, warning and caution notes in these mounting and operating instructions.

Hazards resulting from the special working conditions at the installation site of the valve must be identified in a risk assessment and prevented through the corresponding safety instructions drawn up by the operator.

- Observe safety measures for handling the device as well as fire prevention and explosion protection measures.

Responsibilities of the operator

Operators are responsible for proper use and compliance with the safety regulations. Operators are obliged to provide these mounting and operating instructions as well as the referenced documents to the operating personnel and to instruct them in proper operation. Furthermore, operators must ensure that operating personnel or third parties are not exposed to any danger.

Operators are additionally responsible for ensuring that the limits for the product defined in the technical data are observed. This also applies to the start-up and shutdown procedures. Start-up and shutdown procedures fall within the scope of the operator's duties and, as such, are not part of these mounting and operating instructions. SAMSON is unable to make any statements about these procedures since the operative details (e.g. differential pressures and temperatures) vary in each individual case and are only known to the operator.

Responsibilities of operating personnel

Operating personnel must read and understand these mounting and operating instructions as well as the referenced documents and observe the specified hazard statements, warnings and caution notes. Furthermore, operating personnel must be familiar with the applicable health, safety and accident prevention regulations and comply with them.

Referenced standards, directives and regulations

The control valves comply with the requirements of the European Pressure Equipment Directive 2014/68/EU and the Machinery Directive 2006/42/EC. Valves with a CE marking have a declaration of conformity which includes information about the applied conformity assessment procedure. The 'Certificates' section contains this declaration of conformity.

According to the ignition hazard assessment performed in accordance with Clause 5.2 of ISO 80079-36, the non-electrical control valves do not have their own potential ignition source even in the rare incident of an operating fault. As a result, they do not fall within the scope of Directive 2014/34/EU.

- For connection to the equipotential bonding system, observe the requirements specified in section 6.4 of EN 60079-14 (VDE 0165-1).

Safety instructions and measures

Referenced documentation

The following documents apply in addition to these mounting and operating instructions:

- Mounting and operating instructions for the mounted actuator, e.g. ► EB 8310-X for the SAMSON Type 3271 or Type 3277 Pneumatic Actuator
- Mounting and operating instructions for mounted valve accessories (positioner, solenoid valve etc.)
- ► AB 0100 for tools, tightening torques and lubricant
- Manual ► H 02: Appropriate Machinery Components for SAMSON Pneumatic Control Valves with a Declaration of Conformity of Final Machinery
- For oxygen service: Manual ► H 01

The packaging of valve constructed and sized for oxygen service has the following label on it:

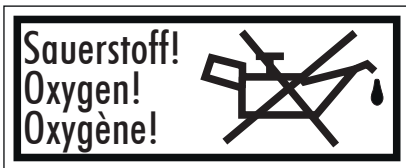

- When a substance is used in the device, which is listed as being a substance of very high concern on the candidate list of the REACH regulation:

Information on safe use of the part affected

► www.samsongroup.com > About SAMSON > Material Compliance > REACH

If a device contains a substance which is listed as being a substance of very high concern on the candidate list of the REACH regulation, this circumstance is indicated on the SAMSON delivery note.

1.1 Notes on possible severe personal injury

DANGER

Risk of bursting in pressure equipment.

Valves and pipelines are pressure equipment. Impermissible pressure or improper opening can lead to valve components bursting.

- Observe the maximum permissible pressure for valve and plant.
- Before starting any work on the control valve, depressurize all plant sections affected as well as the valve.
- Drain the process medium from all the plant sections concerned as well as the valve.

Risk of injury due to incorrect handling of oxygen or cryogenic gases in applications.

The valve can be used for oxygen service or applications with cryogenic gases. Oxygen is a hazardous substance, which reacts quickly, leading to combustion and explosions. Contact with cryogenic gases causes severe frostbite and cold burns (cryogenic burns). Operating personnel must be trained for these applications. Unqualified operating personnel expose themselves and others to an increased risk of injury.

- Operating personnel must be sufficiently trained and be made aware of the hazards in applications involving oxygen or cryogenic gases.
- Instructions and information on how to safely handle devices for oxygen service can be found in the Manual ► H 01.

1.2 Notes on possible personal injury

WARNING

Risk of burn injuries due to hot or cold components and pipelines.

Depending on the process medium, valve components and pipelines may get very hot or cold and cause burn injuries.

- Allow components and pipelines to cool down or warm up to the ambient temperature.
- Wear protective clothing and safety gloves.

WARNING

Risk of hearing loss or deafness due to loud noise.

The noise emissions depend on the valve version, plant facilities and process medium.

- Wear hearing protection when working near the valve.

Risk of personal injury due to exhaust air being vented.

While the valve is operating, air is vented from the actuator, for example, during closed-loop operation or when the valve opens or closes.

- Install the control valve in such a way that vent openings are not located at eye level and the actuator does not vent at eye level in the work position.
- Use suitable silencers and vent plugs.
- Wear eye protection when working in close proximity to the control valve.

Crush hazard arising from moving parts.

The control valve contains moving parts (actuator and plug stem), which can injure hands or fingers if inserted into the valve.

- Do not insert hands or finger into the yoke while the air supply is connected to the actuator.
- Before working on the control valve, disconnect and lock the pneumatic air supply as well as the control signal.
- Do not impede the movement of the actuator and plug stem by inserting objects into the yoke.
- Before unblocking the actuator and plug stem after they have become blocked (e.g. due to seizing up after remaining in the same position for a long time), release any stored energy in the actuator (e.g. spring compression). See associated actuator documentation.

Risk of personal injury due to preloaded springs.

Valves in combination with pneumatic actuators with preloaded springs are under tension. These control valves with SAMSON pneumatic actuators can be identified by the long bolts protruding from the bottom of the actuator.

- Before starting any work on the actuator, relieve the compression from the preloaded springs (see associated actuator documentation).

⚠ WARNING**Risk of personal injury due to residual process medium in the valve.**

While working on the valve, residual medium can flow out of the valve and, depending on its properties, cause personal injury, e.g. (chemical) burns.

- If possible, drain the process medium from all the plant sections affected and the valve.
- Wear protective clothing, safety gloves, respiratory protection and eye protection.

Risk of personal injury due to pressurized components and process medium being discharged.

- Do not loosen the screw of the test connection while the valve is pressurized.

Exposure to hazardous substances poses a serious risk to health.

Certain lubricants and cleaning agents are classified as hazardous substances. These substances have a special label and a material safety data sheet (MSDS) issued by the manufacturer.

- Make sure that an MSDS is available for any hazardous substance used. If necessary, contact the manufacturer to obtain an MSDS.
- Inform yourself about the hazardous substances and their correct handling.

Risk of personal injury through incorrect operation, use or installation as a result of information on the valve being illegible.

Over time, markings, labels and nameplates on the valve may become covered with dirt or become illegible in some other way. As a result, hazards may go unnoticed and the necessary instructions not followed. There is a risk of personal injury.

- Keep all relevant markings and inscriptions on the device in a constantly legible state.
- Immediately renew damaged, missing or incorrect nameplates or labels.

1.3 Notes on possible property damage

! NOTICE

Risk of valve damage due to contamination (e.g. solid particles) in the pipeline.

The plant operator is responsible for cleaning the pipelines in the plant.

→ Flush the pipelines before start-up.

Risk of valve damage due to unsuitable medium properties.

The valve is designed for a process medium with defined properties.

→ Only use the process medium specified for sizing the valve.

Risk of leakage and valve damage due to excessively high or low tightening torques.

Observe the specified torques when tightening control valve components. Excessive tightening torques lead to parts wearing out more quickly. Parts that are too loose may cause leakage.

→ Observe the specified tightening torques (▶ AB 0100).

Risk of valve damage due to the use of unsuitable tools.

Certain tools are required to work on the valve.

→ Only use tools approved by SAMSON (▶ AB 0100).

Risk of valve damage due to the use of unsuitable lubricants.

The lubricants to be used depend on the valve material. Unsuitable lubricants may corrode and damage surfaces.

→ Only use lubricants approved by SAMSON (▶ AB 0100).

Risk of the process medium being contaminated through the use of unsuitable lubricants and/or contaminated tools and components.

→ If necessary (e.g. for oxygen service), keep the valve and the tools used free from solvents and grease.

→ Make sure that only suitable lubricants are used.

1.4 Warnings on the device

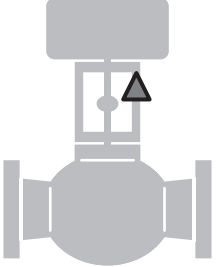
Warning	Meaning of the warning	Location on the device
	<p>Warning against moving parts There is a risk of injury to hands or fingers through the stroking movement of the actuator and plug stem if they are inserted into the yoke while the air supply is connected to the actuator.</p>	

2 Markings on the device

2.1 Valve nameplate

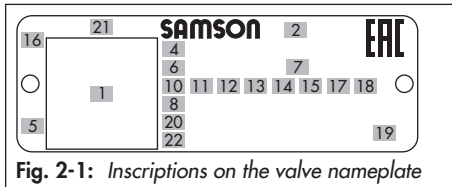

Fig. 2-1: Inscriptions on the valve nameplate

i Note

Fig. 2-1 and the inscription table list all possible characteristics and options that may appear on a valve nameplate. Only the inscriptions relevant to the ordered Type 3296 Valve actually appear on the nameplate.

Item	Inscription meaning
1	Data Matrix code
2	Type designation
4	Material
5	Month and year of manufacture
6	Valve size: DIN: DN · ANSI: NPS · JIS: DN
7	Pressure rating: DIN: PN · ANSI: CL · JIS: K
8	Order number/item
10	Flow coefficient: DIN: KVS · ANSI: CV
11	Characteristic: %: equal percentage · LIN : linear mod-lin : modified linear NO/NC : on/off service
12	Seat-plug seal: ME : metal · HA : carbide metal · ST : metal base material with Stellite® facing KE : ceramic · PT : PTFE soft seal · PK : PEEK soft seal
13	Seat code (trim material): on request
14	Pressure balancing: DIN: D · ANSI/JIS: B Version: M : mixing valve · V : flow-diverting valve

Item	Inscription meaning
15	Noise reduction: 1 : flow divider (ST) 1 · 2 : ST 2 · 3 : ST 3 1/PSA : ST 1 standard and integrated in seat for PSA valve · AC-1/AC-2/AC-3/AC-5 : AC trim, versions 1 to 5 · LK : perforated plug · LK1/LK2/LK3 : perforated plug with flow divider ST 1 to ST 3 · MHCT : multi-hole cage · CC1 : Combi Cage · ZT1 : Zero Travel
16	Country of origin
17	PSA version: PSA
18	Cage/seat style: CC : clamped cage, clamped seat SF : suspended cage, flanged seat
19	CE marking
20	ID of the notified body PED : Pressure Equipment Directive G1/G2 : gases and vapors Fluid group 1 = hazardous Fluid group 2 = other L1 : liquids Fluid group 1 = hazardous Fluid group 2 = other I/II/III : Category 1 to 3
21	Serial number
22	NE 53 (NAMUR Recommendation)

Markings on the device

The nameplate is affixed to the yoke of the valve (see Fig. 2-2).

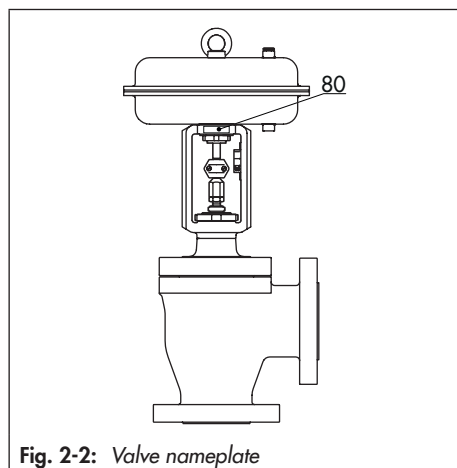

Fig. 2-2: Valve nameplate

2.2 Actuator nameplate

See associated actuator documentation.

2.3 Material identification number

The seat and plug of the valves have an item number written on them. You can contact us stating this item number to find out which material is used. Additionally, a seat code is used to identify the trim material. This seat code is specified on the nameplate.

2.4 Label when an adjustable packing is installed

An instructional label is affixed to the valve when an adjustable packing is installed (see Fig. 2-3).

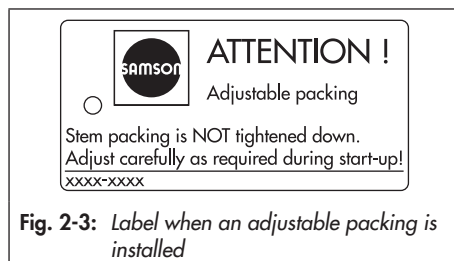

Fig. 2-3: Label when an adjustable packing is installed

3 Design and principle of operation

The Type 3296 Angle Valve with clamped seat is preferably combined with a SAMSON Type 3271 or Type 3277 Pneumatic Actuator. It can also be combined with other actuators.

The seat (4), plug with plug stem (5) and seat retainer (124) are installed in the body (1). The seat is inserted into the seat bridge. The seat and seat retainer are clamped into place by tightening the body nuts (14). In versions with flow divider, it takes over the function as a seat retainer, i.e. the seat (4) is clamped in place by the flow divider (62).

The plug stem is connected to the actuator stem (A7) by the stem connector clamps (A26/27) and is sealed by a spring-loaded V-ring packing or an adjustable high-temperature packing.

The springs in the pneumatic actuator are located either above or below the diaphragm depending on the selected fail-safe action (see section 3.1). A change in the signal pressure acting on the diaphragm causes the

plug to move. The actuator size is determined by the diaphragm area.

The process medium flows through the valve in the direction indicated by the arrow on the body in the flow-to-open (FTO) direction. A rise in signal pressure causes the force acting on the diaphragm in the actuator to increase. The springs are compressed. Depending on the selected direction of action, the actuator stem retracts or extends. As a result, the plug position in the seat changes, which together with the seat retainer's contour, determines the released cross-section and the flow rate as well.

Tip

We recommend the use of positioners with integrated diagnostic firmware (see section 3.4) for valves used for on/off service. The partial stroke test included in this software helps prevent a shut-off valve normally in its end position from seizing up or getting jammed.

Legend for Fig. 3-1

1 Body	15 Packing	A4 Diaphragm
2 Bonnet	17 Body gasket	A7 Actuator stem
4 Seat	60 Yoke assembly	A8 Ring nut
5 Plug (with plug stem)	92 Castellated nut	A10 Spring
8 Threaded bushing (packing nut)	124 Seat retainer	A26/ 27 Stem connector clamps
10 Lock nut	125 Spacer ring	S Signal pressure connection
14 Body nut	126 Seat retainer gasket	
	127 Seat bridge gasket	

Design and principle of operation

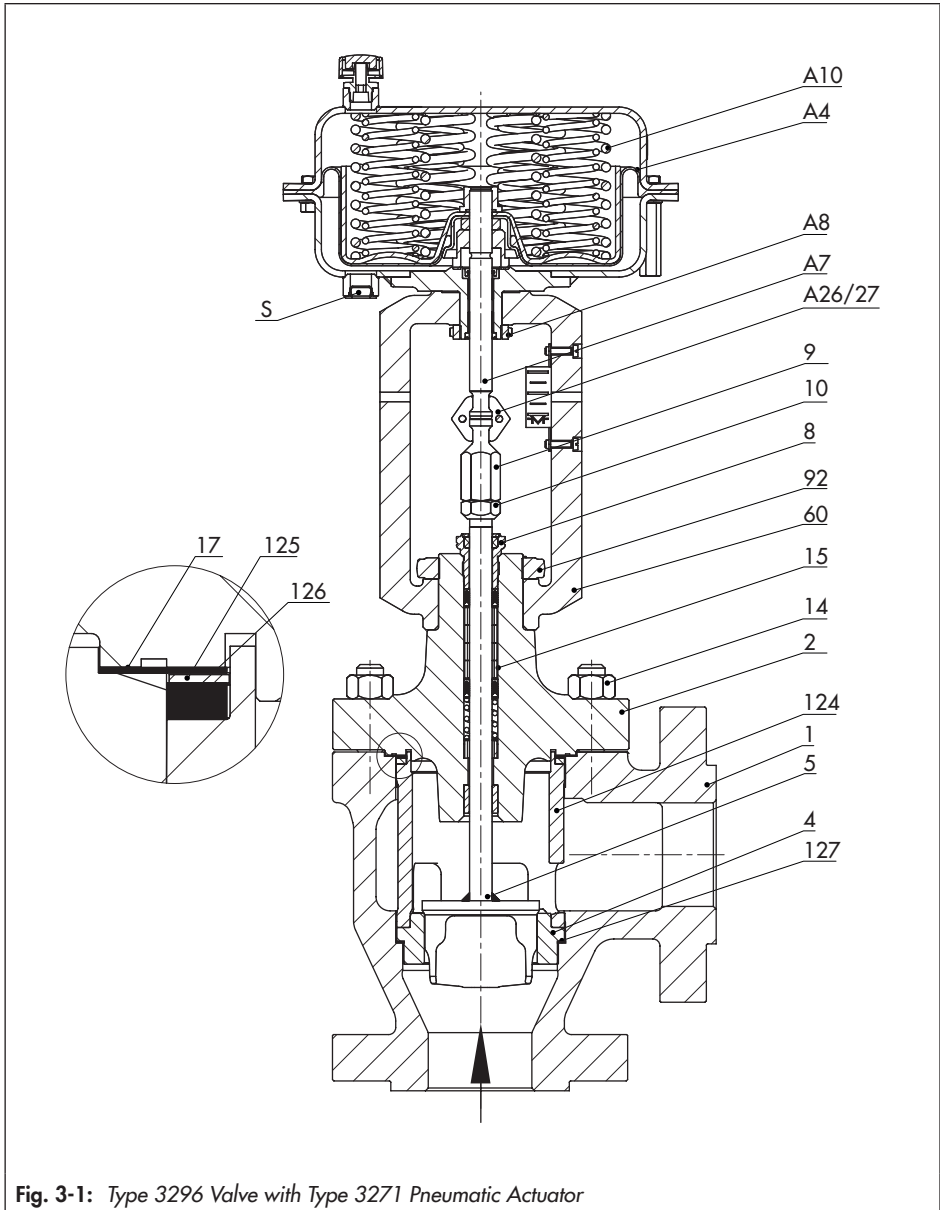

Fig. 3-1: Type 3296 Valve with Type 3271 Pneumatic Actuator

3.1 Fail-safe positions

The fail-safe position of the control valve upon air supply or control signal failure depends on the actuator used (see associated actuator documentation).

Depending on how the compression springs are arranged in the SAMSON Type 3271 and Type 3277 Pneumatic Actuator, the valve has one of two different fail-safe positions:

– **Actuator stem extends (FA)**

When the signal pressure is reduced or the air supply fails, the springs move the actuator stem downward and close the valve. The valve opens when the signal pressure is increased enough to overcome the force exerted by the springs.

– **Actuator stem retracts (FE)**

When the signal pressure is reduced or the air supply fails, the springs move the actuator stem upwards and open the valve. The valve closes when the signal pressure is increased enough to overcome the force exerted by the springs.



Tip

The actuator's direction of action can be reversed, if required. Refer to the mounting and operating instructions of the pneumatic actuator:

► EB 8310-X for Type 3271 and Type 3277

3.2 Versions

With insulating section/bellows seal

The modular design allows an insulating section or bellows seal to be fitted to the standard valve version.

Actuators

In these instructions, the preferable combination with a SAMSON Type 3271 or Type 3277 Pneumatic Actuator is described. The pneumatic actuator (with or without handwheel) can be replaced by another pneumatic actuator in a different size, but with the same travel.

→ Observe the maximum permissible actuator force.

Note

If the travel range of the actuator is larger than the travel range of the valve, the spring assembly in the actuator must be preloaded so that the travel ranges match. See associated actuator documentation.

The basic pneumatic actuator can be replaced by a pneumatic actuator with additional handwheel or by an electric actuator (see Information Sheet ► T 8300).

3.3 Additional fittings

Strainers

We recommend installing a SAMSON strainer upstream of the valve. It prevents solid particles in the process medium from damaging the valve.

Design and principle of operation

Bypass and shut-off valves

We recommend installing a shut-off valve both upstream of the strainer and downstream of the valve and installing a bypass line. The bypass ensures that the plant does not need to be shut down for service and repair work on the valve.

Insulation

Control valves can be insulated to reduce heat energy transfer. Refer to the instructions in the 'Installation' section.

Test connection

Versions with bellows seal fitted with a test connection (G 1/8) at the top flange allow the sealing ability of the bellows to be monitored.

Particularly for liquids and vapors, we recommend installing a suitable leakage indicator (e.g. a contact pressure gauge, an outlet to an open vessel or an inspection glass).

Safety guard

For operating conditions that require increased safety (e.g. in cases where the valve is freely accessible to untrained staff), a safety guard must be installed to rule out a crush hazard arising from moving parts (actuator and plug stem). Plant operators are responsible for deciding whether a guard is to be used. The decision is based on the risk posed by the plant and its operating conditions.

Noise reduction

Trims with flow dividers can be used to reduce noise emission (▶ T 8081).

3.4 Valve accessories

Information Sheet ▶ T 8350

3.5 Technical data

The nameplates on the valve and actuator provide information on the control valve version. See the 'Markings on the device' section.

i Note

More information is available in Data Sheet ▶ T 8074-1.

Noise emissions

SAMSON is unable to make general statements about noise emissions. The noise emissions depend on the valve version, plant facilities and process medium.

Table 3-1: Technical data for Type 3296

Material		Cast steel	Cast steel	Cast steel	Cast stainless steel	
		A352 LCC	A216 WCC	A217 WC6	A351 CF3M	A351 CF8M
Valve size		NPS ½ to 8				
Pressure rating		Class 150 to 900				
Type of connection	Flanges	All ANSI versions				
	Welding ends	According to ANSI B16.25				
Seat-plug seal		Metal seal · Soft seal · High-performance metal seal				
Characteristic		Equal percentage · Linear · On/off				
Rangeability		50:1				
Compliance						
Temperature ranges in °F (°C) · Permissible operating pressures according to pressure-temperature diagrams (see Information Sheet ▶ T 8000-2)						
Body without insulating section		14 to 428 (-10 to +220) · Up to 660 (350) with high-temperature packing depending on material				
Body with	Insulating section	-51 to +649 (-46 to +343)	-20 to +800 (-29 to +425)	-20 to +842 (-29 to +450)	-325 to +842 (-196 to +450)	-325 to +842 (-196 to +450)
	Bellows seal	-51 to +649 (-46 to +343)	-20 to +800 (-29 to +425)	-20 to +842 (-29 to +450)	-325 to +842 (-196 to +450)	-325 to +842 (-196 to +450)
Valve plug ¹⁾	Standard	Metal seal	-325 to +842 (-196 to +450)			
		Soft seal	-325 to +428 (-196 to +220)			
	Balanced with PTFE ring	-40 to +428 (-40 to +220) · Lower temperatures on request				
	Balanced with graphite ring	-40 to +842 (-40 to +450)				
Leakage class according to ANSI/FCI 70-2						
Valve plug	Standard	Metal seal	IV · High-performance metal seal: V			
		Soft seal ²⁾	VI			
	Balanced, metal seal	Standard: IV (with PTFE or graphite ring) High-performance metal seal: V (only with PTFE ring)				

¹⁾ Only in combination with suitable body material

²⁾ On request

Design and principle of operation

Dimensions and weights

Dimensions in mm and inches · Weights in kg and pounds

Table 3-2: *Dimensions for Type 3296*

Valve	NPS		½	1	1½	2	3	4	6	8	
DN			15	25	40	50	80	100	150	200	
Length L1	Class 150	in	3.62	3.62	4.37	5.0	5.88	6.94	8.88	10.69	
		mm	92	92	111	127	149	176	226	272	
	Class 300	in	3.75	3.88	4.62	5.25	6.25	7.25	9.31	11.19	
		mm	95	99	117	133	159	184	236	284	
	Class 600	in	4.00	4.12	4.94	5.62	6.62	7.75	10.00	12.00	
		mm	101	105	125	143	168	197	254	305	
	Class 900	in	4.25	5.00	6.00	7.25	7.50	9.00	12.00	14.50	
		mm	108	127	152	184	190	229	305	368	
Height H4	Class 150 to 600	in	5.28	5.08	5.08	6.89	6.30	6.69	9.17	On request	
		mm	134	129	129	175	160	170	233		
	Class 900	in	6.89	6.69	6.69	8.70	6.30	6.69	9.17		
		mm	175	170	170	221	160	170	233		
H8 for actua- tor	350 cm ²	in	9.45	9.45	9.45	9.45	9.45	9.45	-		
		mm	240	240	240	240	240	240	-		
	355 cm ²	in	9.45	9.45	9.45	9.45	9.45	9.45	15.55	-	
		mm	240	240	240	240	240	240	395		
	700 cm ²	in	9.45	9.45	9.45	9.45	9.45	9.45	15.55	15.55	
		mm	240	240	240	240	240	240	395	395	
	1000 cm ²	in	-				11.61	11.61	11.61	15.55	15.55
		mm	-				295	295	295	395	395
	1400-60 cm ²	in	-				11.61	11.61	11.61	15.55	15.55
		mm	-				295	295	295	395	395
	1400-120 cm ²	in	-						18.90	18.90	18.90
		mm	-						480	480	480
2800 cm ²	in	-						18.90	18.90	18.90	
	mm	-						480	480	480	

Table 3-3: Weights for Type 3296

Valve		NPS	1/2	1	1 1/2	2	3	4	6	8
Valve without actuator (approx.)	Class 150 and 300	lbs	26	On request		77	128	165	419	On req.
		kg	12			35	58	75	190	
	Class 600	lbs	On request			128	203	On request		
		kg				58	92			
	Class 900	lbs	On req.	84	126	200	242			
		kg		38	57	91	110			

Dimensional drawings

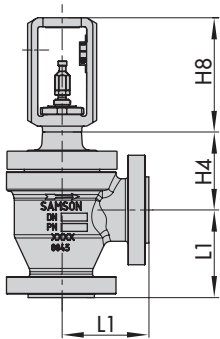

Type 3296 Valve with flanges

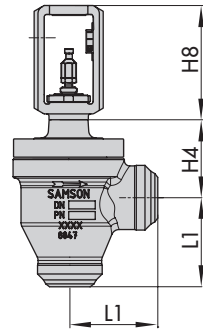

Type 3296 Valve with welding ends

i Note

Refer to the following data sheet for more dimensions and weights:

▶ T 8074-1

The associated actuator documentation applies to actuators, e.g. SAMSON pneumatic actuators:

▶ T 8310-1 for Type 3271 or Type 3277 Pneumatic Actuators up to 750 cm² actuator area

▶ T 8310-2 for Type 3271 Actuator with 1000 cm² actuator area and larger

▶ T 8310-3 for Type 3271 Actuator with 1400-60 cm² actuator area

▶ T 8312 for Type 3273 Hand-operated Actuator

4 Shipment and on-site transport

The work described in this section is only to be performed by personnel appropriately qualified to carry out such tasks.

4.1 Accepting the delivered goods

After receiving the shipment, proceed as follows:

1. Check the scope of delivery. Check that the specifications on the valve nameplate match the specifications in the delivery note. See the 'Markings on the device' section for nameplate details.
2. Check the shipment for transportation damage. Report any damage to SAMSON and the forwarding agent (refer to delivery note).
3. Determine the weight and dimensions of the units to be lifted and transported in order to select the appropriate lifting equipment and lifting accessories, if required. Refer to the transport documents and the 'Technical data' section.

4.2 Removing the packaging from the valve

Observe the following sequence:

- Do not open or remove the packaging until immediately before lifting to install the valve into the pipeline.

- Leave the control valve in its transport container or on the pallet to transport it on site.
- Do not remove the protective caps from the inlet and outlet until immediately before installing the valve into the pipeline. They prevent foreign particles from entering the valve.
- Dispose and recycle the packaging in accordance with the local regulations.

4.3 Transporting and lifting the valve

⚠ DANGER

Danger due to suspended loads falling.

- *Stay clear of suspended or moving loads.*
 - *Close off and secure the transport paths.*
-

⚠ WARNING

Risk of lifting equipment tipping over and risk of damage to lifting accessories due to exceeding the rated lifting capacity.

- *Only use approved lifting equipment and accessories whose minimum lifting capacity is higher than the weight of the valve (including actuator and packaging, if applicable).*
-

WARNING

Risk of personal injury due to the control valve tipping over.

- Observe the valve's center of gravity.
 - Secure the valve against tipping over or turning.
-

WARNING

Risk of injury due to incorrect lifting without the use of lifting equipment.

Lifting the control valve without the use of lifting equipment may lead to injuries (back injury in particular) depending on the weight of the control valve.

- Observe the occupational health and safety regulations valid in the country of use.
-

NOTICE

Risk of valve damage due to incorrectly attached slings.

The lifting eyelet/eyebolt on SAMSON actuators is only intended for mounting and removing the actuator as well as lifting the actuator without valve. Do not use this lashing point to lift the entire control valve assembly.

- When lifting the control valve, make sure that the slings attached to the valve body bear the entire load.
 - Do not attach load-bearing slings to the actuator, handwheel or any other parts.
 - Observe lifting instructions (see section 4.3.2).
-

Tip

A swivel hoist can be screwed into SAMSON actuators with a female thread on the top diaphragm case in place of the eyebolt (see associated actuator documentation). In contrast to the lifting eyelet/eyebolt, the swivel hoist is designed for setting a control valve assembly upright.

The sling between the swivel hoist and rigging equipment (hook, shackle etc.) must not bear any load when lifting a control valve assembly. The sling only protects the control valve from tilting while being lifted.

Tip

Our after-sales service can provide more detailed transport and lifting instructions on request.

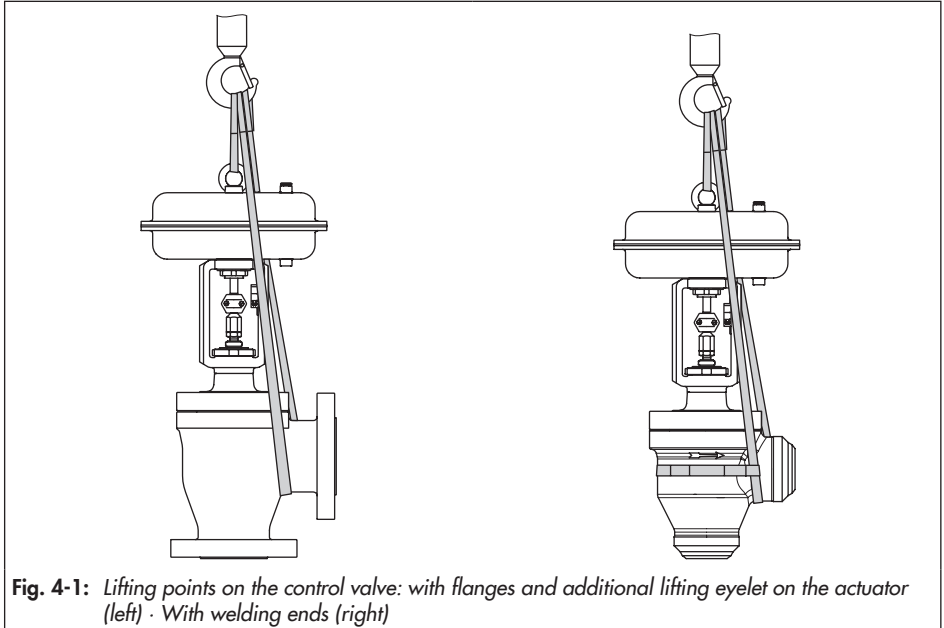

Fig. 4-1: Lifting points on the control valve: with flanges and additional lifting eyelet on the actuator (left) · With welding ends (right)

4.3.1 Transporting the valve

The control valve can be transported using lifting equipment (e.g. crane or forklift).

- ➔ Leave the control valve in its transport container or on the pallet to transport it.
- ➔ Observe the transport instructions.

Transport instructions

- Protect the control valve against external influences (e.g. impact).
- Do not damage the corrosion protection (paint, surface coatings). Repair any damage immediately.
- Protect the piping and any mounted valve accessories against damage.

- Protect the control valve against moisture and dirt.
- The permissible transportation temperature of standard control valves is -20 to $+65$ °C (-4 to $+149$ °F).

i Note

Contact our after-sales service for the transportation temperatures of other valve versions.

4.3.2 Lifting the valve

To install a large valve into the pipeline, use lifting equipment (e.g. crane or forklift) to lift it.

Shipment and on-site transport

Lifting instructions

- Use a hook with safety latch (see Fig. 4-1) to secure the slings from slipping off the hook during lifting and transporting.
- Secure slings against slipping.
- Make sure the slings can be removed from the valve once it has been installed into the pipeline.
- Prevent the control valve from tilting or tipping over.
- Do not leave loads suspended when interrupting work for longer periods of time.
- Make sure that the axis of the pipeline is always horizontal during lifting and the axis of the plug stem is always vertical.
- Make sure that the additional sling between the lashing point on the actuator and rigging equipment (hook, shackle etc.) does not bear any load when lifting valves with an actuator that has a lifting eyelet/eyebolt on it. The sling only protects the control valve from tilting while being lifted. Before lifting the control valve, tighten the sling.

a) Version with flanges

1. Attach one sling to each flange of the body and to the rigging equipment (e.g. hook) of the crane or forklift (see Fig. 4-1).
2. **NPS 6 and larger:** attach another sling to the lashing point on the actuator and to the rigging equipment.

3. Carefully lift the control valve. Check whether the lifting equipment and accessories can bear the weight.
4. Move the control valve at an even pace to the site of installation.
5. Install the valve into the pipeline (see the 'Installation' section).
6. After installation in the pipeline, check whether the flanges are bolted tight and the valve in the pipeline holds.
7. Remove slings.

b) Version with welding ends

1. Attach one sling to each welding end of the body and to the rigging equipment (e.g. hook) of the crane or forklift (see Fig. 4-1).
2. Secure the slings attached to the body against slipping using a connector.
3. **NPS 6 and larger:** attach another sling to the lashing point on the actuator and to the rigging equipment.
4. Carefully lift the control valve. Check whether the lifting equipment and accessories can bear the weight.
5. Move the control valve at an even pace to the site of installation.
6. Install the valve into the pipeline (see the 'Installation' section).
7. After installation, check whether the weld seams hold.
8. Remove slings.

4.4 Storing the valve

NOTICE

Risk of valve damage due to improper storage.

- Observe the storage instructions.
- Avoid long storage times.
- Contact SAMSON in case of different storage conditions or longer storage times.

Note

We recommend regularly checking the control valve and the prevailing storage conditions during long storage periods.

Storage instructions

- Protect the control valve against external influences (e.g. impact).
- Secure the valve in the stored position against slipping or tipping over.
- Do not damage the corrosion protection (paint, surface coatings). Repair any damage immediately.
- Protect the control valve against moisture and dirt. Store it at a relative humidity of less than 75 %. In damp spaces, prevent condensation. If necessary, use a drying agent or heating.
- Make sure that the ambient air is free of acids or other corrosive media.
- The permissible storage temperature of standard control valves is -20 to $+65$ °C (-4 to $+149$ °F). Contact our after-sales

service for the storage temperatures of other valve versions.

- Do not place any objects on the control valve.

Special storage instructions for elastomers

Elastomer, e.g. actuator diaphragm

- To keep elastomers in shape and to prevent cracking, do not bend them or hang them up.
- We recommend a storage temperature of 15 °C (59 °F) for elastomers.
- Store elastomers away from lubricants, chemicals, solutions and fuels.

Tip

SAMSON's After-sales Service can provide more detailed storage instructions on request.

5 Installation

The work described in this section is only to be performed by personnel appropriately qualified to carry out such tasks.

5.1 Installation conditions

Work position

The work position for the control valve is the front view looking onto the operating controls (including valve accessories).

Plant operators must ensure that, after installation of the device, the operating personnel can perform all necessary work safely and easily access the device from the work position.

Pipeline routing

The inlet and outlet lengths (see Table 5-1) vary depending on several variables and process conditions and are intended as recommendations. Contact SAMSON if the lengths are significantly shorter than the recommended lengths.

To ensure that the valve functions properly, proceed as follows:

- ➔ Observe the recommended inlet and outlet lengths (see Table 5-1). Contact SAMSON if the valve conditions or states of the medium process deviate.
- ➔ Install the valve free of stress and with the least amount of vibrations as possible. Read information under 'Mounting position' and 'Adjusting the packing' in this section.

- ➔ Install the valve allowing sufficient space to remove the actuator and valve or to perform service and repair work on them.

Mounting position

Generally, we recommend installing the valve with the actuator upright and on top of the valve.

In the following versions, the valve must be installed with the actuator on top:

- Valves in NPS 4 and larger
 - Valves with insulating section for low temperatures below -10 °C (14 °F)
- ➔ Contact SAMSON if the mounting position is not as specified above.

Support or suspension

Note

The plant engineering company is responsible for selecting and implementing a suitable support or suspension of the installed control valve and the pipeline.

Depending on the valve version and mounting position, the valve, actuator and pipeline must be supported or suspended.

Valves, which are not installed in the pipeline in the upright position with the actuator on top, must be supported or suspended.

Valve accessories

- ➔ During connection of valve accessories, make sure that they are easily accessible and can be operated safely from the work position.

Installation

Table 5-1: Inlet and outlet lengths

State of process medium		Valve conditions	Inlet length a	Outlet length b
Inlet	Outlet			
Gas		$Ma \leq 0.3$	2	4
		$0.3 \leq Ma \leq 0.7$	2	10
Vapor		$Ma \leq 0.3$ ¹⁾	2	4
		$0.3 \leq Ma \leq 0.7$ ¹⁾	2	10
		Saturated steam (percentage of condensate > 5 %)	2	20
Liquid		Free of cavitation/ $w < 10$ m/s	2	4
		Cavitation producing noise/ $w \leq 3$ m/s	2	4
		Cavitation producing noise/ $3 < w < 5$ m/s	2	10
		Critical cavitation/ $w \leq 3$ m/s	2	10
		Critical cavitation/ $3 < w < 5$ m/s	2	20
Liquid	Liquid, with flashing	–	2	20
Multi-phase		–	10	20

¹⁾ No saturated steam

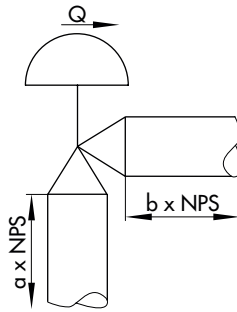

Q Flow rate
a Inlet length
b Outlet length

Vent plugs

Vent plugs are screwed into the exhaust air ports of pneumatic and electropneumatic devices. They ensure that any exhaust air that forms can be vented to the atmosphere (to avoid excess pressure in the device). Furthermore, the vent plugs allow air intake to prevent a vacuum from forming in the device.

- ➔ Locate the vent plug on the opposite side to the work position of operating personnel.

5.2 Preparation for installation

Before installation, make sure the following conditions are met:

- The valve is clean.
- The valve and all valve accessories (including piping) are not damaged.
- The valve data on the nameplate (type designation, valve size, material, pressure rating and temperature range) match the plant conditions (size and pressure rating of the pipeline, medium temperature etc.). See the 'Markings on the device' section for nameplate details.
- The requested or required additional pipe fittings (see 'Additional fittings' in the 'Design and principle of operation' section) have been installed or prepared as necessary before installing the valve.

! NOTICE

Risk of control valve damage due to incorrect insulation.

- ➔ Only insulate control valves with insulating section or bellows seal up to the bonnet flange of the valve body for medium temperatures below 0 °C (32 °F) and above 220 °C (428 °F). If the insulating section is insulated, it will not function properly.
 - ➔ Do not insulate valves mounted to comply with NACE MR0175 requirements and which have nuts and bolts that are not suitable for sour gas environments.
-

Proceed as follows:

- ➔ Lay out the necessary material and tools to have them ready during installation work.
 - ➔ Flush the pipelines.
-

i Note

The plant operator is responsible for cleaning the pipelines in the plant.

- ➔ For steam applications, dry the pipelines. Moisture will damage the inside of the valve.
- ➔ Check any mounted pressure gauges to make sure they function properly.
- ➔ When the valve and actuator are already assembled, check the tightening torques of the bolted joints (▶ AB 0100). Components may loosen during transport.

5.3 Mounting the device

The activities listed below are necessary to install the valve and before it can be started up.

! NOTICE***Risk of valve damage due to excessively high or low tightening torques.***

Observe the specified torques when tightening control valve components. Excessive tightening torques lead to parts wearing out more quickly. Parts that are too loose may cause leakage.

→ *Observe the specified tightening torques (▶ AB 0100).*

! NOTICE***Risk of valve damage due to the use of unsuitable tools.***

→ *Only use tools approved by SAMSON (▶ AB 0100).*

5.3.1 Mounting the external anti-rotation fixture

Before mounting the actuator, the external anti-rotation fixture must be mounted onto the plug stem in some cases. The valve must be closed beforehand.

For SAMSON Type 3271 and Type 3277 Actuators with Type 3273 Hand-operated Actuator, observe the mounting and operating instructions of the hand-operated actuator (handwheel) to mount the anti-rotation fixture ▶ EB 8312-X.

a) Standard version for Series 290 Valves, NPS 6 and larger

See Fig. 5-1 and Fig. 5-2

1. Insert ball bearings (310) into the recesses in the bonnet.
2. Place the yoke (3) on the bonnet in such a way that the ball bearings fit into the recesses of the yoke.
3. Fasten the yoke (3) using the castellated nut (92).
4. Fasten the hanger (83) and warning label (255), if applicable, to the yoke using the screws (82).
5. Position the travel indicator scale (84) on the hanger (83) with the screws (85) according to Table 5-3.
6. Use a soft-faced hammer or lever press to press the sliding washers (309) with their beveled part first (without using any lubricant) into the recesses of the clamps

(301) as far as they will go. Remove any excess material.

7. Apply a thin film of lubricant (114) to the threads of the stem (9) and screws (303).

! NOTICE

Impaired functioning due to incorrectly applied lubricant.

→ Do not apply any lubricant to the threads of the clamps (301) or the plug stem.

8. Position the clamps (301) and stem (9) on the plug stem according to Table 5-3 and tighten screws (303) and washers (304) by hand.
9. Mount the actuator. See section 5.3.2.
10. Thread the stem (9) upwards until the head of the stem rests on the extended actuator stem.
11. Retract the actuator stem to relieve the stem (9).
12. Gradually tighten the screws (303) in a crisscross pattern. Observe the tightening torques specified in Table 5-4.

Table 5-4: Tightening torques

Screw size	Tightening torque [Nm]
M12	50
M16	121

13. Check and ensure the following:
 - There is a nominal clearance of 0.5 to 1 mm between the sliding washers and their contact surface on the yoke

- on each side (see detailed view Y in Fig. 5-2).
- The anti-rotation fixture does not get stuck on the yoke and can move freely in the direction of travel.

14. Extend the actuator stem again and mount the stem connector clamps.

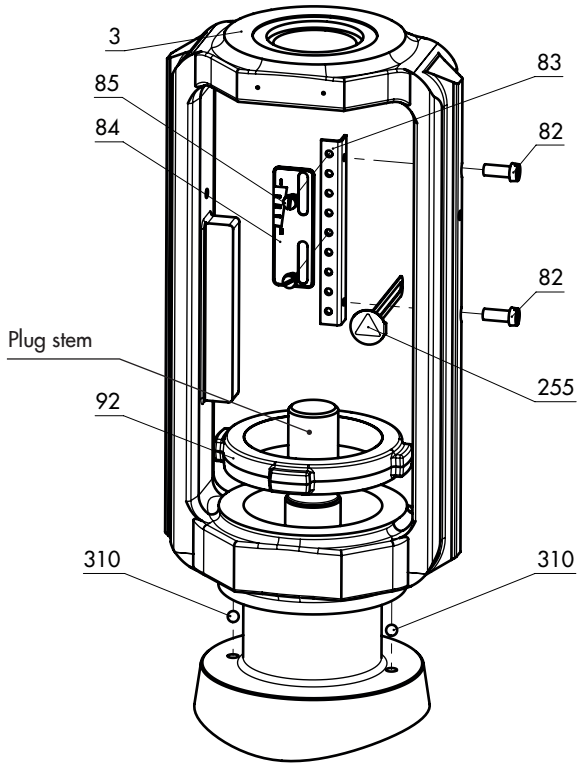

Legend

- 3 Yoke
- 82 Screws
- 83 Hanger
- 84 Travel indicator scale
- 85 Screws
- 92 Castellated nut
- 255 Warning label
- 310 Ball bearing

Fig. 5-1: Overview of yoke assembly with travel indicator scale in the standard version

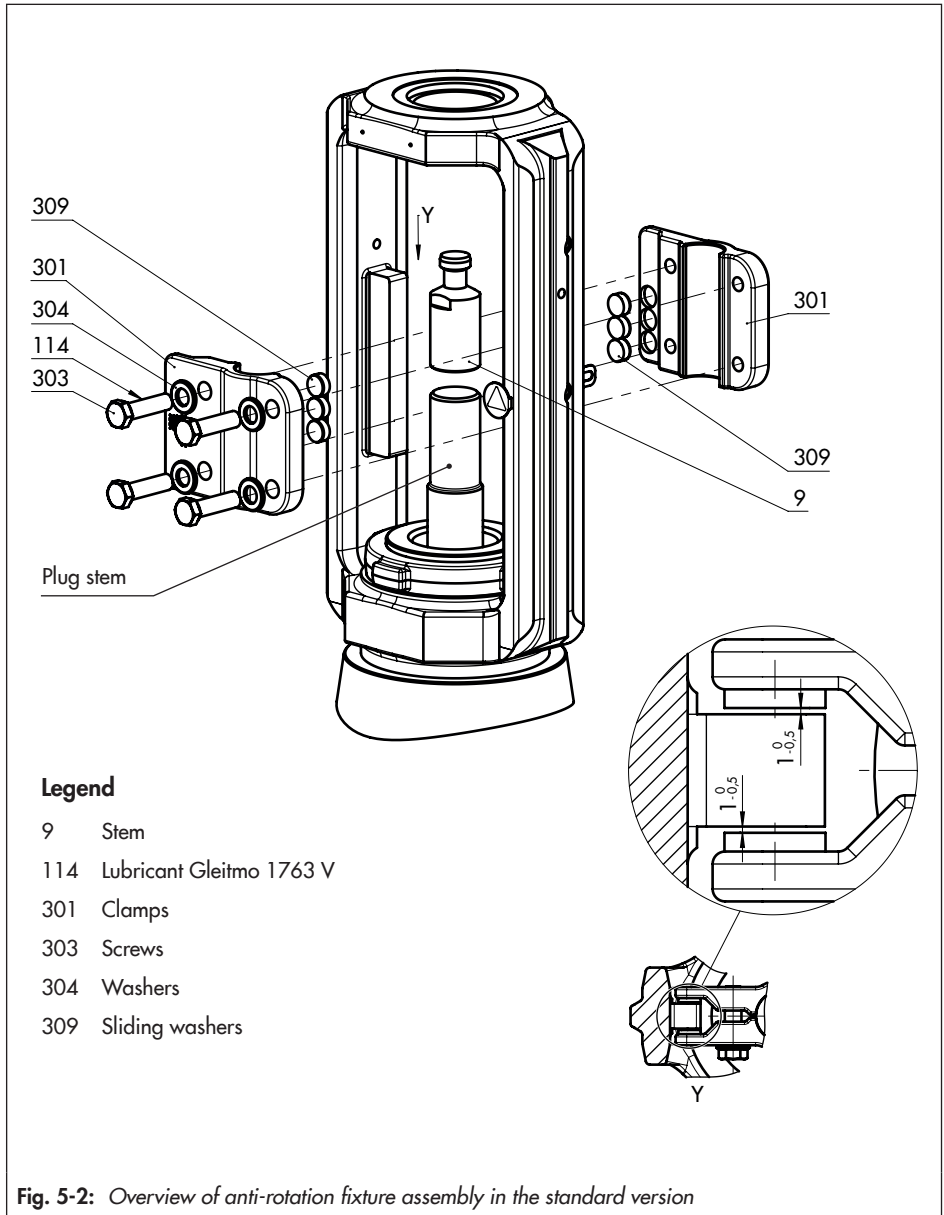

Fig. 5-2: Overview of anti-rotation fixture assembly in the standard version

b) Special version for Series 290 Valves, NPS 2 to 4

See Fig. 5-3 and Fig. 5-4

1. Fasten the travel indicator scale (84) with hanger (83) and warning label (255), if applicable, to the yoke using the screws (82). While fastening it, position the travel indicator scale (84) on the hanger (83) according to Table 5-3.
2. Screw tight the holder (302) using the screws (306) and washers (308). Observe the tightening torques specified in Table 5-2.
3. Fasten the yoke (3) using the castellated nut (92).
4. Use a soft-faced hammer or lever press to press the sliding washers (309) (without using any lubricant) into the holes of the clamps (301) as far as they will go. Remove any excess material.
5. Apply a thin film of lubricant (114) to the threads of the stem (9) and screws (303).

⚠ NOTICE

Impaired functioning due to incorrectly applied lubricant.

➔ Do not apply any lubricant to the threads of the clamps (301) or the plug stem.

6. Position the clamps (301) and stem (9) on the plug stem according to Table 5-3 and tighten screws (303) and washers (304) by hand.
7. Mount the actuator. See section 5.3.2.

8. Thread the stem (9) upwards until the head of the stem rests on the extended actuator stem.
9. Retract the actuator stem to relieve the stem (9).
10. Gradually tighten the screws (303) in a crisscross pattern. Observe the tightening torques specified in Table 5-2.

Table 5-2: Tightening torques

Item	Screw size	Tightening torque [Nm]
306	M10	30
303	M8	15

11. Check and ensure the following:
 - There is a nominal clearance of 0.5 to 1 mm between the sliding washers and their contact surface on the yoke on each side (see detailed view Y in Fig. 5-4).
 - The anti-rotation fixture does not get stuck on the yoke and can move freely in the direction of travel.
12. Extend the actuator stem again and mount the stem connector clamps.

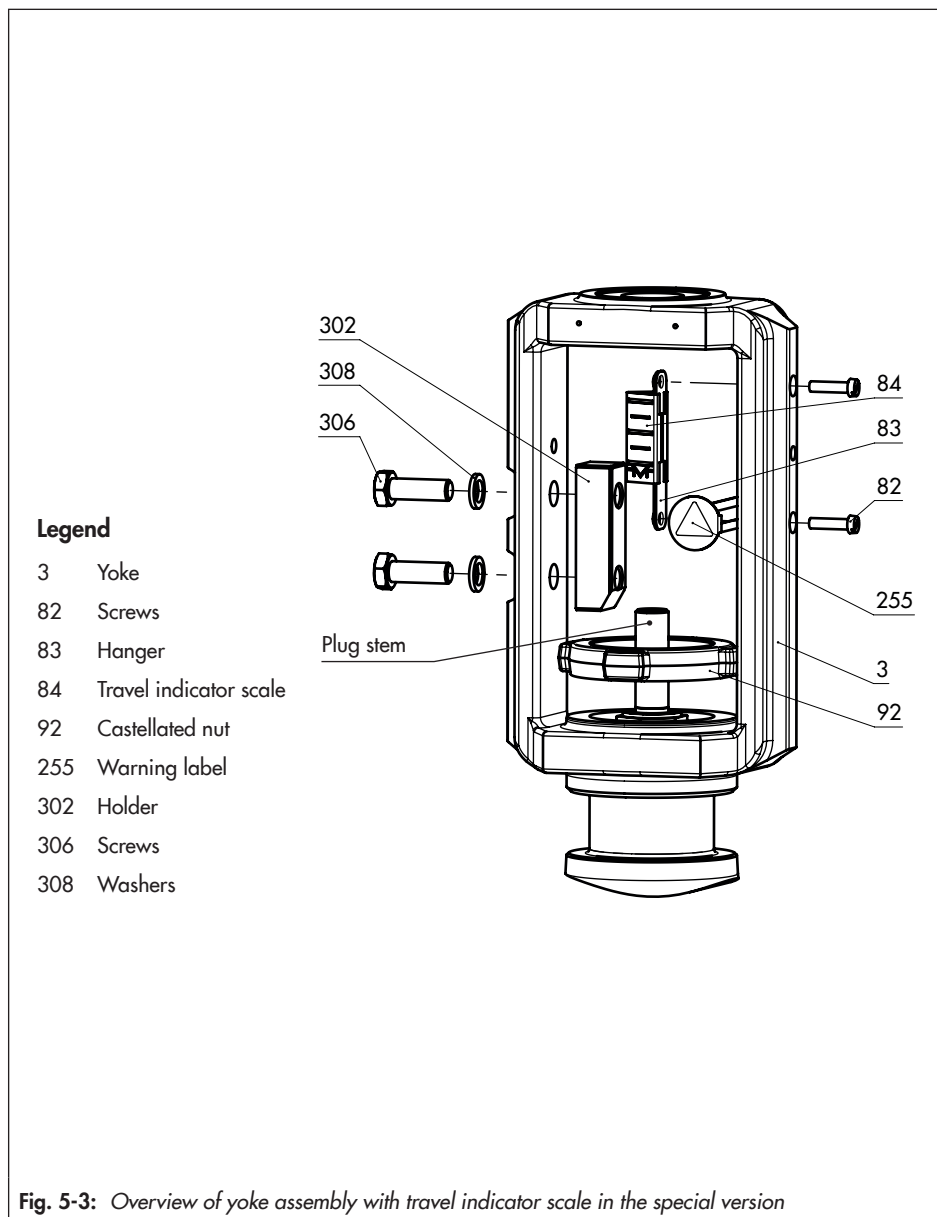

Fig. 5-3: Overview of yoke assembly with travel indicator scale in the special version

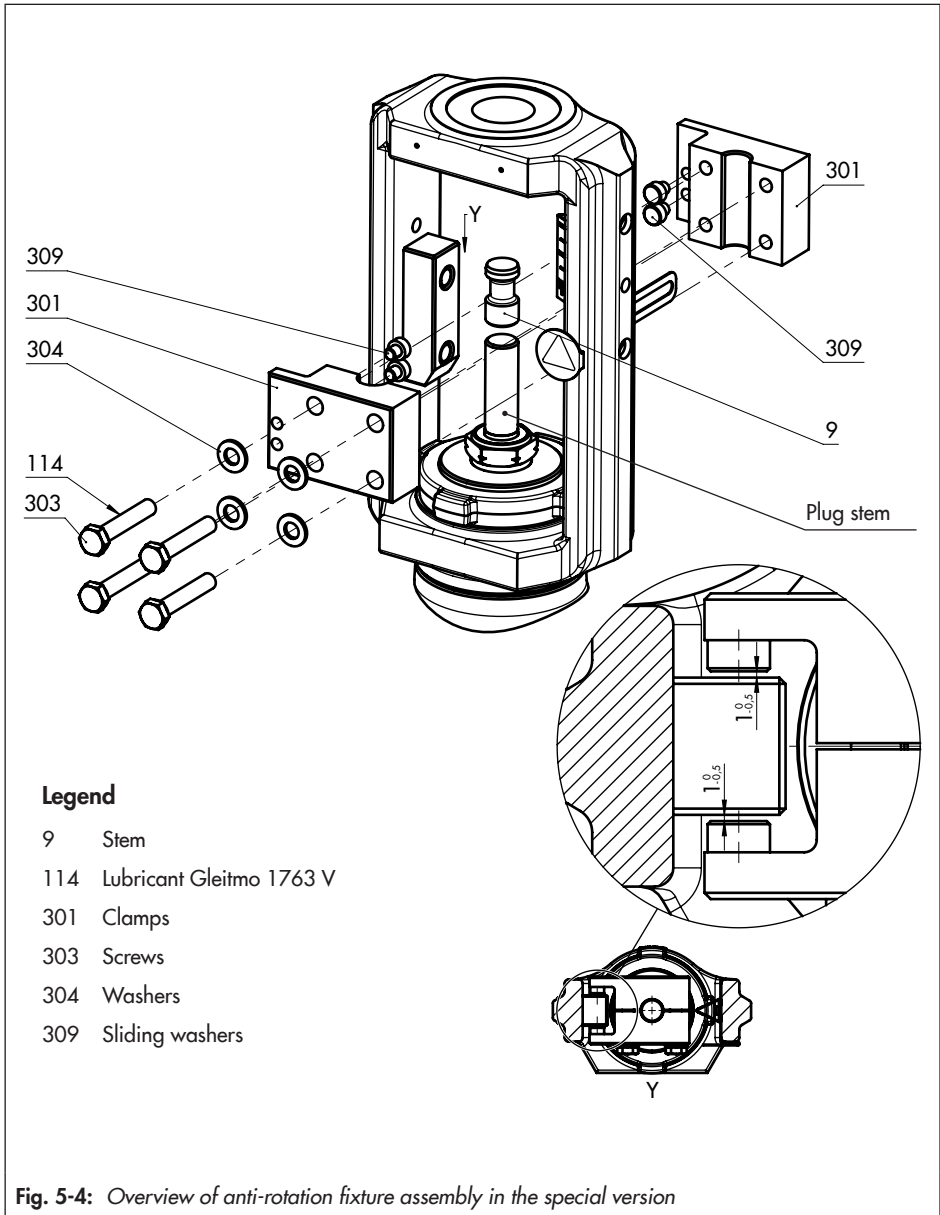

Fig. 5-4: Overview of anti-rotation fixture assembly in the special version

Table 5-3: Mounting dimensions for Types 3271 and 3277 Pneumatic Actuators · See Fig. 5-5 for dimensional drawing

Actuator [cm ²]	Travel [mm]	Actuator preloading		Dimension when the valve is closed [mm]									
		[%]	[mm]	H _F	H _G	H _I	H _K	H _L	H _N	H _O	H _T		
NPS 2 to 4 · Special version													
350	15	0	0	111	75	192	54	-	66	42	-		
	15	25	3.75	115	71								
355 700 750	15	50	15	111	75								
	15	75	22.5	118.5	67.5								
	30	0	0	96	90							34.5	30
	30	25	7.5	103.5	82.5							34.5	30
1000 1400-60	15	100	60	136	105								
	30	75	45	121	120			-	-				
1400-120	30	75	90	231	195			-	-				
2800	30	100	120	231	195			-	-				
NPS 6 · Standard version													
355 700 750	15	0	0	263.5	67.5			192	87	48	105	70	145
	15	50	15	256	75	145							
	15	75	22.5	263.5	67.5	145							
	30	0	0	241	90	120							
	30	25	7.5	248.5	82.5	120							
1000 1400-60	15	100	60	226	105	103							
	30	0	0	211	120	88							
	30	75	45	211	120	88							
	60	0	0	166	165	58							
	60	25	15	181	150	58							
1400-120	15	87.5	105	236	180	63	105						
	30	0	0	191	225	75							
	30	75	90	221	195	105							
	60	0	0	191	225	75							
	60	50	60	191	225	75							
	60	75	90	191	225	75							
2800 5600	30	0	0	191	225	48	75						
	30	100	120	221	195	105							
	60	0	0	191	225	75							
	60	75	90	191	225	75							

Installation

Actuator [cm ²]	Travel [mm]	Actuator preloading		Dimension when the valve is closed [mm]							
		[%]	[mm]	H _F	H _G	H _I	H _K	H _L	H _N	H _O	H _T
NPS 8 to 10 up to seat bore 200 · Standard version											
355 700 750	30	0	0	241	90	195	87	61	108	65	120
1000 1400-60	30	0	0	211	120			66			83
	30	75	45	211	120			66			83
	60	0	0	166	165			52			55
	60	25	15	181	150			52			55
1400-120	15	87.5	105	236	180			61			115
	30	0	0	191	225			48			76
	30	75	90	221	195			61			100
	60	0	0	308	255			61			185
	60	50	60	191	225			48			76
2800 5600	30	0	0	191	225			48			76
	30	100	120	221	195			61			100
	60	0	0	308	255			61			185
	60	75	90	191	225			48			76

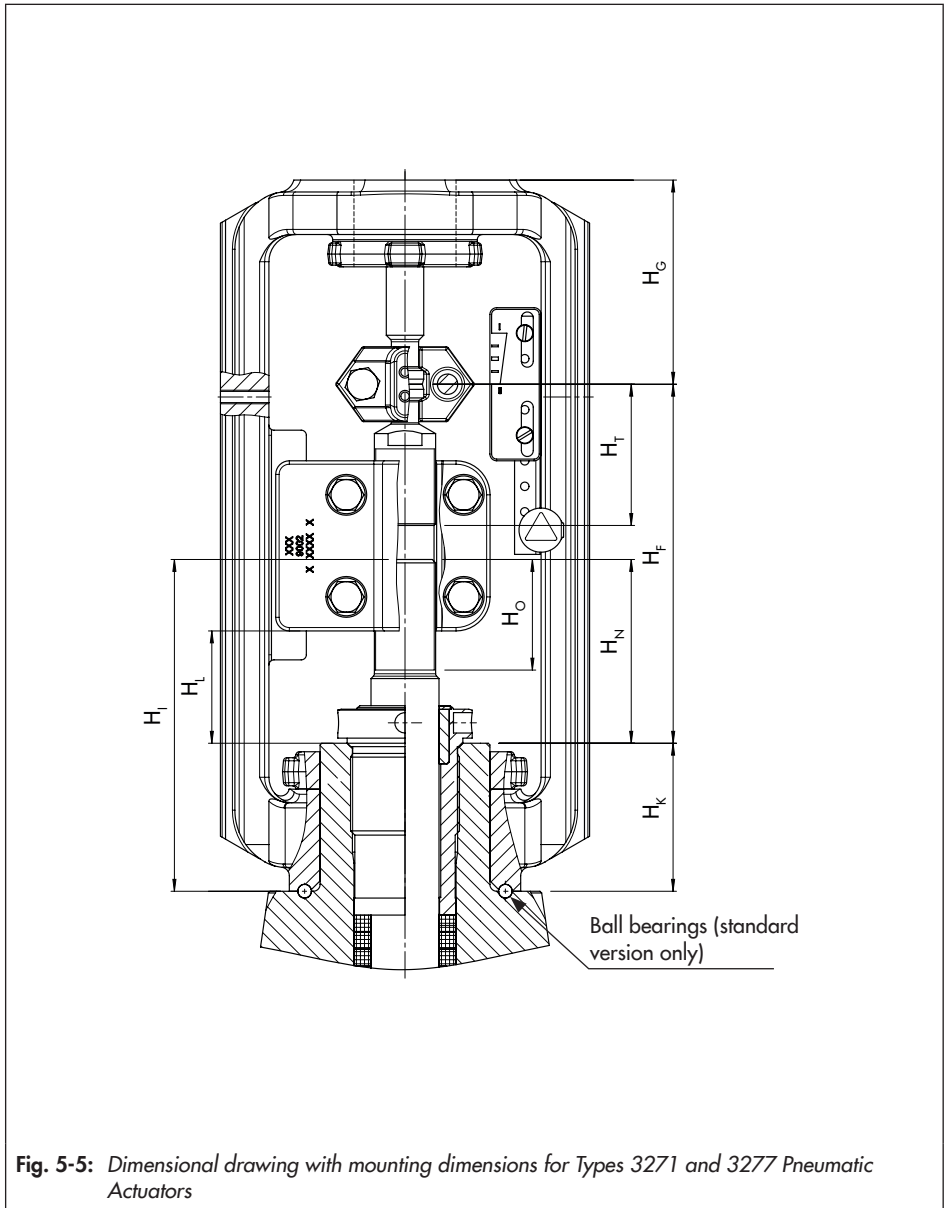

Fig. 5-5: Dimensional drawing with mounting dimensions for Types 3271 and 3277 Pneumatic Actuators

5.3.2 Mounting the actuator onto the valve

⚠ WARNING

Risk of personal injury due to preloaded springs.

Actuators with preloaded springs are under tension. They can be identified by the long bolts protruding from the bottom of the actuator.

- Before starting any work on the actuator, relieve the compression from the preloaded springs (see associated actuator documentation).

⚠ WARNING

Risk of personal injury due to incorrect removal of the anti-rotation fixture under tension.

Once the actuator has been mounted on the valve and the assembly is ready for use, the clamps (301) of the anti-rotation fixture on the plug stem are under tension.

- Follow the instructions in this document during mounting or removal.
- Do not loosen the screws (303) of the anti-rotation fixture while the force generated by the supply air and/or the actuator springs is transmitted to the actuator stem and the stem (9).
- First remove the actuator from the valve or ensure it cannot transmit any forces to the actuator stem before removing the anti-rotation fixture on the plug stem.

Depending on the version, SAMSON control valves are either delivered with the actuator already mounted on the valve or the valve and actuator are delivered separately. When delivered separately, the valve and actuator must be assembled together on site.

Versions with V-port plug

To achieve the best flow conditions inside the valve, the V-port plug must always be installed with the port that releases the flow first when the valve opens facing toward the valve outlet. This is the largest of the three V-shaped ports (see Fig. 5-6).

- Before mounting the actuator, determine which V-shaped port is uncovered first when the plug is lifted out of the seat.
- On mounting the actuator, make sure that the V-shaped port uncovered first faces toward the valve outlet.

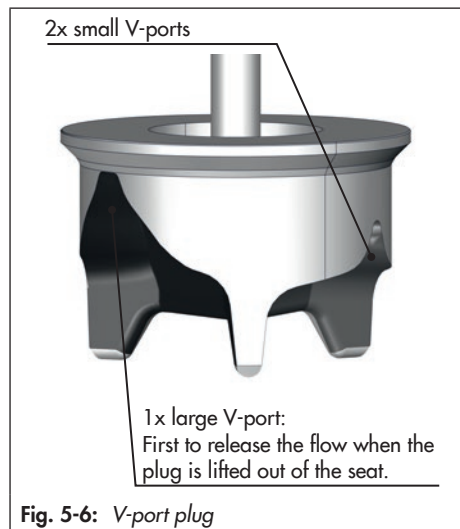

Fig. 5-6: V-port plug

Versions with perforated plug

Only one hole is located near the seal facing of perforated plugs with equal percentage characteristic. Depending on the valve size, the hole pattern varies and is partly unsymmetrical. The process medium in the valve flows through the holes as soon as the plug is lifted out of the seat. To achieve the best flow conditions inside the valve, the perforated plug must always be installed with the hole that releases the flow first when the valve opens facing toward the valve outlet (see Fig. 5-7).

- Before mounting the actuator, check the hole pattern of the perforated plug and determine which hole is the closest to the seal facing and is uncovered first when the plug is lifted out of the seat.
- On mounting the actuator, make sure that the hole uncovered first faces toward the valve outlet.

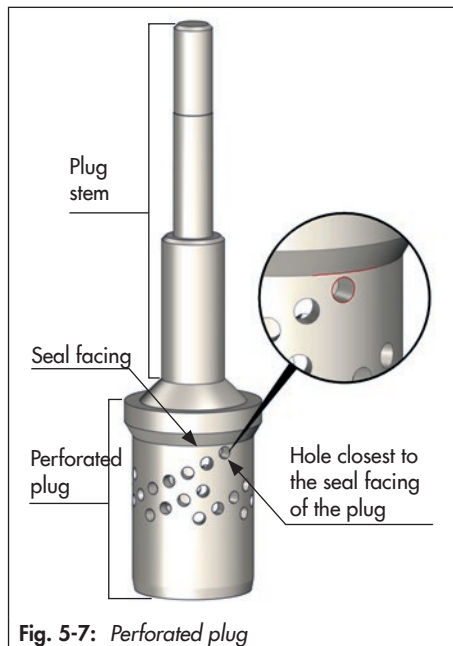

Fig. 5-7: Perforated plug

a) Mounting the actuator

- To mount the actuator, proceed as described in the associated actuator documentation.

b) Aligning the travel indicator scale

After mounting the actuator, the travel indicator scale must be aligned. To do so, align '0' on the travel indicator scale with the tip of the stem connector clamp (see Fig. 5-5).

1. Move the valve to the closed position.
2. Loosen the screws on the travel indicator scale.
3. Align the travel indicator scale.

4. Fix the travel indicator scale into place by tightening the screws.

5.3.3 Installing the valve into the pipeline

NOTICE

Risk of valve damage due to work being carried out by personnel not qualified for such tasks.

The plant operator or specialist company performing the welding is responsible for the selection of the welding procedure and the actual welding operations on the valve. This also applies to any required heat treatment to be performed on the valve.

→ *Only allow qualified welding personnel to carry out welding operations.*

NOTICE

Premature wear and leakage due to insufficient support or suspension.

→ *Support or suspend the valve sufficiently at suitable points.*

a) Version with flanges

1. Close the shut-off valves in the pipeline at the inlet and outlet of the plant section while the valve is being installed.
2. Prepare the relevant section of the pipeline for installing the valve.
3. Remove the protective caps from the valve ports before installing the valve.

4. Lift the valve using suitable lifting equipment to the site of installation (see information under 'Lifting the valve' in the 'Shipment and on-site transport' section). Observe the flow direction through the valve. The arrow on the valve indicates the direction of flow.
5. Make sure that the correct flange gaskets are used.
6. Bolt the pipe to the valve free of stress.
7. Attach a support or suspension on the valve, if necessary.

b) Version with welding ends

1. Proceed as described for 'Version with flanges' (steps 1 to 4).
2. Completely retract the actuator stem to protect the plug from sparks during welding.
3. Weld the valve free of stress into the pipeline.
4. Attach a support or suspension on the valve, if necessary.

5.4 Testing the installed valve

⚠ DANGER

Risk of bursting due to incorrect opening of pressurized equipment or components.

Valves and pipelines are pressure equipment that may burst when handled incorrectly. Flying projectile fragments or the release of process medium under pressure can cause serious injury or even death.

Before working on the control valve:

- ➔ Depressurize all plant sections affected and the valve (including the actuator). Release any stored energy.
- ➔ Drain the process medium from all the plant sections concerned as well as the valve.

⚠ WARNING

Risk of personal injury due to pressurized components and process medium being discharged.

- ➔ Do not loosen the screw of the test connection while the valve is pressurized.

⚠ WARNING

Risk of hearing loss or deafness due to loud noise.

Noise emission (e.g. cavitation or flashing) may occur during operation caused by the process medium and the operating conditions. Additionally, a loud noise may briefly occur through the sudden venting of the pneumatic actuator or pneumatic valve accessories not fitted with noise-reducing fittings. Both can damage hearing.

➔ Wear hearing protection when working near the valve.

⚠ WARNING

Crush hazard arising from actuator and plug stem moving.

- ➔ Do not insert hands or finger into the yoke while the air supply is connected to the actuator.
- ➔ Before working on the control valve, disconnect and lock the pneumatic air supply as well as the control signal.
- ➔ Do not impede the movement of the actuator and plug stem by inserting objects into the yoke.
- ➔ Before unblocking the actuator and plug stem after they have become blocked (e.g. due to seizing up after remaining in the same position for a long time), release any stored energy in the actuator (e.g. spring compression). See associated actuator documentation.

⚠ WARNING

Risk of personal injury due to exhaust air being vented.

While the valve is operating, air is vented from the actuator, for example, during closed-loop operation or when the valve opens or closes.

- ➔ Wear eye protection when working in close proximity to the control valve.

WARNING

Risk of personal injury due to preloaded springs.

Actuators with preloaded springs are under tension. They can be identified by the long bolts protruding from the bottom of the actuator.

→ Before starting any work on the actuator, relieve the compression from the preloaded springs (see associated actuator documentation).

To test the valve functioning before start-up or putting back the valve into operation, perform the following tests:

5.4.1 Leak test

The plant operator is responsible for performing the leak test and selecting the test method. The leak test must comply with the requirements of the national and international standards that apply at the site of installation.

Tip

Our after-sales service can support you to plan and perform a leak test for your plant.

1. Close the valve.
2. Slowly apply the test medium to the inlet space upstream of the valve. A sudden surge in pressure and resulting high flow velocities can damage the valve.
3. Open the valve.
4. Apply the required test pressure.

5. Check the valve for leakage to the atmosphere.
6. Depressurize the pipeline section and valve.
7. Rework any parts that leak (see information below under 'Adjusting the packing') and repeat the leak test.

Adjusting the packing

A label on the yoke indicates whether an adjustable packing is installed (see the 'Markings on the device' section).

NOTICE

Risk of valve damage due to the use of unsuitable tools.

→ A special tool is required for form HT packings (▶ AB 0100).

NOTICE

Impaired valve functioning due to increased friction as a result of the threaded bushing being tightened too far.

→ Make sure that the plug stem can still move smoothly after the threaded bushing has been tightened.

1. Tighten the threaded bushing gradually (by turning it clockwise) until the packing seals the valve.
2. Open and close the valve several times.
3. Check the valve for leakage to the atmosphere.
4. Repeat steps 1 and 2 until the packing completely seals the valve.

- If the adjustable packing does not seal properly, contact our after-sales service.

5.4.2 Travel motion

The movement of the actuator stem must be linear and smooth.

- Apply the maximum and minimum control signals to check the end positions of the valve while observing the movement of the actuator stem.
- Check the travel reading at the travel indicator scale.

5.4.3 Fail-safe position

- Shut off the signal pressure line.
- Check whether the valve moves to the fail-safe position (see the 'Design and principle of operation' section).

5.4.4 Pressure test

The plant operator is responsible for performing the pressure test.

**Tip**

Our after-sales service can support you to plan and perform a pressure test for your plant.

During the pressure test, make sure the following conditions are met:

- Retract the plug stem to open the valve.
- Observe the maximum permissible pressure for both the valve and plant.

6 Start-up

The work described in this section is only to be performed by personnel appropriately qualified to carry out such tasks.

⚠ WARNING

Risk of burn injuries due to hot or cold components and pipeline.

Valve components and the pipeline may become very hot or cold. Risk of burn injuries.

- Allow components and pipelines to cool down or warm up to the ambient temperature.
- Wear protective clothing and safety gloves.

⚠ WARNING

Risk of personal injury due to pressurized components and process medium being discharged.

- Do not loosen the screw of the test connection while the valve is pressurized.

⚠ WARNING

Risk of hearing loss or deafness due to loud noise.

Noise emission (e.g. cavitation or flashing) may occur during operation caused by the process medium and the operating conditions. Additionally, a loud noise may briefly occur through the sudden venting of the pneumatic actuator or pneumatic valve accessories not fitted with noise-reducing fittings. Both can damage hearing.

- Wear hearing protection when working near the valve.

⚠ WARNING

Crush hazard arising from actuator and plug stem moving.

- Do not insert hands or finger into the yoke while the air supply is connected to the actuator.
- Before working on the control valve, disconnect and lock the pneumatic air supply as well as the control signal.
- Do not impede the movement of the actuator and plug stem by inserting objects into the yoke.
- Before unblocking the actuator and plug stem after they have become blocked (e.g. due to seizing up after remaining in the same position for a long time), release any stored energy in the actuator (e.g. spring compression). See associated actuator documentation.

⚠ WARNING

Risk of personal injury due to exhaust air being vented.

While the valve is operating, air is vented from the actuator, for example, during closed-loop operation or when the valve opens or closes.

- Wear eye protection when working in close proximity to the control valve.

Start-up

Before start-up or putting the valve back into service, make sure the following conditions are met:

- The valve is properly installed into the pipeline (see the 'Installation' section).
- The leak and function tests have been completed successfully (see 'Testing the installed valve' in the 'Installation' section).
- The prevailing conditions in the plant section concerned meet the valve sizing requirements (see information under 'Intended use' in the 'Safety instructions and measures' section).

Start-up/putting the valve back into operation

1. Allow the valve to cool down or warm up to reach ambient temperature before start-up when the ambient temperature and process medium temperature differ greatly or the medium properties require such a measure.
2. Slowly open the shut-off valves in the pipeline. Slowly opening these valves prevents a sudden surge in pressure and high flow velocities which can damage the valve.
3. Check the valve to ensure it functions properly.

7 Operation

Immediately after completing start-up or putting the valve back into operation, the valve is ready for use.

⚠ WARNING

Risk of burn injuries due to hot or cold components and pipeline.

Valve components and the pipeline may become very hot or cold. Risk of burn injuries.

- Allow components and pipelines to cool down or warm up to the ambient temperature.
- Wear protective clothing and safety gloves.

⚠ WARNING

Risk of personal injury due to pressurized components and process medium being discharged.

- Do not loosen the screw of the test connection while the valve is pressurized.

⚠ WARNING

Risk of hearing loss or deafness due to loud noise.

Noise emission (e.g. cavitation or flashing) may occur during operation caused by the process medium and the operating conditions. Additionally, a loud noise may briefly occur through the sudden venting of the pneumatic actuator or pneumatic valve accessories not fitted with noise-reducing fittings. Both can damage hearing.

- Wear hearing protection when working near the valve.

⚠ WARNING

Crush hazard arising from actuator and plug stem moving.

- Do not insert hands or finger into the yoke while the air supply is connected to the actuator.
- Before working on the control valve, disconnect and lock the pneumatic air supply as well as the control signal.
- Do not impede the movement of the actuator and plug stem by inserting objects into the yoke.
- Before unblocking the actuator and plug stem after they have become blocked (e.g. due to seizing up after remaining in the same position for a long time), release any stored energy in the actuator (e.g. spring compression). See associated actuator documentation.

⚠ WARNING

Risk of personal injury due to exhaust air being vented.

While the valve is operating, air is vented from the actuator, for example, during closed-loop operation or when the valve opens or closes.

- Wear eye protection when working in close proximity to the control valve.

7.1 Normal operation

The handwheel of valves with actuators fitted with a handwheel must be in the neutral position during normal operation.

7.2 Manual operation

Valves with actuators fitted with a handwheel can be manually closed or opened in case of supply air failure.

8 Malfunctions

Read hazard statements, warnings and caution notes in the 'Safety instructions and measures' section.

8.1 Troubleshooting

Malfunction	Possible reasons	Recommended action
Actuator and plug stem does not move on demand.	Actuator is blocked.	Check attachment. Remove the blockage. WARNING! A blocked actuator or plug stem (e.g. due to seizing up after remaining in the same position for a long time) can suddenly start to move uncontrollably. Injury to hands or fingers is possible if they are inserted into the actuator or valve. Before trying to unblock the actuator or plug stem, disconnect and lock the pneumatic air supply as well as the control signal. Before unblocking the actuator, release any stored energy in the actuator (e.g. spring compression). See associated actuator documentation.
	Diaphragm in the actuator defective	See associated actuator documentation.
	Signal pressure too low	Check the signal pressure. Check the signal pressure line for leakage.
Jolting movement of the actuator and plug stem	Version with adjustable packing ¹⁾ ; packing not tightened correctly	Tighten the packing correctly (see information under 'Adjusting the packing' in the 'Installation' section > 'Testing the installed valve').
Actuator and plug stem does not stroke through the entire range.	Signal pressure too low	Check the signal pressure. Check the signal pressure line for leakage.
	Travel stop active	See associated actuator documentation.
	Incorrect setting of valve accessories	Check the settings of the valve accessories.

Malfunctions

Malfunction	Possible reasons	Recommended action
Increased flow through closed valve (seat leakage)	Dirt or other foreign particles deposited between the seat and plug.	Shut off the section of the pipeline and flush the valve.
	Valve trim is worn out.	Replace seat and plug (see the 'Servicing' section) or contact our after-sales service.
	Gasket (127) underneath the seat bridge is worn out.	Replace gasket (see the 'Servicing' section) or contact our after-sales service.
	Gasket (126) at the seat retainer (124) or flow divider (62) is worn out.	Replace gasket (see the 'Servicing' section) or contact our after-sales service.
The valve leaks to the atmosphere (fugitive emissions).	Defective packing	Replace packing (see the 'Servicing' section) or contact our after-sales service.
	Version with adjustable packing ¹⁾ : packing not tightened correctly	Adjust the packing (see information under 'Adjusting the packing' in the 'Installation' section > 'Testing the installed valve'). Contact our after-sales service when it continues to leak.
	Version with bellows seal: the bellows seal is defective.	Contact our after-sales service.
	Flange joint loose or gasket worn out	Check the flange joint. Replace gasket at the flanged joint (see the 'Servicing' section) or contact our after-sales service.

¹⁾ See the 'Markings on the device' section

i Note

Contact our after-sales service for malfunctions not listed in the table.

8.2 Emergency action

Plant operators are responsible for emergency action to be taken in the plant.

In the event of a valve malfunction:

1. Close the shut-off valves upstream and downstream of the control valve to stop the process medium from flowing through the valve.
2. Perform troubleshooting (see section 8.1).
3. Rectify those malfunctions that can be remedied based on the instructions provided here. Contact our after-sales service in all other cases.

Putting the valve back into operation after a malfunction

See the 'Start-up' section.

9 Servicing

The work described in this section is only to be performed by personnel appropriately qualified to carry out such tasks.

The following documents are also required for servicing the valve:

- Mounting and operating instructions for the mounted actuator, e.g. ► EB 8310-X for Type 3271 or Type 3277 Pneumatic Actuator
- ► AB 0100 for tools, tightening torques and lubricant

! DANGER

Risk of bursting due to incorrect opening of pressurized equipment or components.

Valves and pipelines are pressure equipment that may burst when handled incorrectly. Flying projectile fragments or the release of process medium under pressure can cause serious injury or even death.

Before working on the control valve:

- Depressurize all plant sections affected and the valve (including the actuator). Release any stored energy.
- Drain the process medium from all the plant sections concerned as well as the valve.

! WARNING

Risk of burn injuries due to hot or cold components and pipeline.

Valve components and the pipeline may become very hot or cold. Risk of burn injuries.

- Allow components and pipelines to cool down or warm up to the ambient temperature.
- Wear protective clothing and safety gloves.

! WARNING

Risk of personal injury due to pressurized components and process medium being discharged.

- Do not loosen the screw of the test connection while the valve is pressurized.

! WARNING

Risk of hearing loss or deafness due to loud noise.

Noise emission (e.g. cavitation or flashing) may occur during operation caused by the process medium and the operating conditions. Additionally, a loud noise may briefly occur through the sudden venting of the pneumatic actuator or pneumatic valve accessories not fitted with noise-reducing fittings. Both can damage hearing.

- Wear hearing protection when working near the valve.

! WARNING

Crush hazard arising from actuator and plug stem moving.

- Do not insert hands or finger into the yoke while the air supply is connected to the actuator.

Servicing

- Before working on the control valve, disconnect and lock the pneumatic air supply as well as the control signal.
- Do not impede the movement of the actuator and plug stem by inserting objects into the yoke.
- Before unblocking the actuator and plug stem after they have become blocked (e.g. due to seizing up after remaining in the same position for a long time), release any stored energy in the actuator (e.g. spring compression). See associated actuator documentation.

⚠ WARNING

Risk of personal injury due to exhaust air being vented.

While the valve is operating, air is vented from the actuator, for example, during closed-loop operation or when the valve opens or closes.

- Wear eye protection when working in close proximity to the control valve.

⚠ WARNING

Risk of personal injury due to preloaded springs.

Actuators with preloaded springs are under tension. They can be identified by the long bolts protruding from the bottom of the actuator.

- Before starting any work on the actuator, relieve the compression from the preloaded springs (see associated actuator documentation).

⚠ WARNING

Risk of personal injury due to residual process medium in the valve.

While working on the valve, residual medium can flow out of the valve and, depending on its properties, cause personal injury, e.g. (chemical) burns.

- Wear protective clothing, safety gloves, respiratory protection and eye protection.

ⓘ NOTICE

Risk of valve damage due to excessively high or low tightening torques.

Observe the specified torques when tightening control valve components. Excessive tightening torques lead to parts wearing out more quickly. Parts that are too loose may cause leakage.

- Observe the specified tightening torques (▶ AB 0100).

ⓘ NOTICE

Risk of valve damage due to the use of unsuitable tools.

- Only use tools approved by SAMSON (▶ AB 0100).

ⓘ NOTICE

Risk of valve damage due to the use of unsuitable lubricants.

- Only use lubricants approved by SAMSON (▶ AB 0100).

i Note

The control valve was checked by SAMSON before it left the factory.

- Certain test results certified by SAMSON lose their validity when the valve is opened. Such testing includes seat leakage and leak tests.
- The product warranty becomes void if service or repair work not described in these instructions is performed without prior agreement by SAMSON's After-sales Service.
- Only use original spare parts by SAMSON, which comply with the original specifications.

9.1 Periodic testing

Depending on the operating conditions, check the valve at certain intervals to prevent possible failure before it can occur. Plant operators are responsible for drawing up an inspection and test plan.

 **Tip**

Our after-sales service can support you in drawing up an inspection and test plan for your plant.

We recommend the following inspection and testing which can be performed while the process is running:

Inspection and testing	Action to be taken in the event of a negative result:
Check the markings, labels and nameplates on the valve for their readability and completeness.	Immediately renew damaged, missing or incorrect nameplates or labels.
	Clean any inscriptions that are covered with dirt and are illegible.
Check the pipe connections and gaskets on the valve and actuator for leakage.	Check the bolted joint (tightening torque).
	Replace the gaskets (see section 9.4.2)
	Version with adjustable packing ¹⁾ : adjust the packing (see information under 'Adjusting the packing' in the 'Installation' section > 'Testing the installed valve') or replace the packing (see section 9.4.3).

Servicing

Inspection and testing	Action to be taken in the event of a negative result:
<p>Check the test connection and bellows seal (if used) for external leakage. WARNING! Risk of personal injury due to pressurized components and process medium being discharged. Do not loosen the screw of the test connection while the valve is pressurized.</p>	<p>Put the control valve out of operation (see the 'Decommissioning' section). To repair the bellows seal, contact our after-sales service (see the 'Repairs' section).</p>
<p>Check the valve's seat leakage.</p>	<p>Shut off the section of the pipeline and flush the valve to remove any dirt and/or deposited foreign particles between the seat and plug.</p>
<p>Check the valve for external damage (e.g. corrosion).</p>	<p>Repair any damage immediately. If necessary, put the control valve out of operation (see the 'Decommissioning' section).</p>
<p>Check the valve accessories to ensure they are mounted properly.</p>	<p>Tighten the connections of the valve accessories.</p>
<p>Check to ensure that the actuator and plug stem move smoothly.</p>	<p>Version with adjustable packing ¹⁾: tighten the packing correctly (see information under 'Adjusting the packing' in the 'Installation' section > 'Testing the installed valve').</p>
	<p>Unblock a blocked actuator and plug stem. WARNING! A blocked actuator or plug stem (e.g. due to seizing up after remaining in the same position for a long time) can suddenly start to move uncontrollably. Injury to hands or fingers is possible if they are inserted into the actuator or valve. Before trying to unblock the actuator or plug stem, disconnect and lock the pneumatic air supply as well as the control signal. Before unblocking the actuator, release any stored energy in the actuator (e.g. spring compression). See associated actuator documentation.</p>
<p>If possible, check the valve's fail-safe position by briefly interrupting the air supply.</p>	<p>Put the control valve out of operation (see the 'Decommissioning' section). Identify the cause for the malfunction and rectify it (see the 'Troubleshooting' section).</p>

¹⁾ See the 'Markings on the device' section

9.2 Preparing the valve for service work

WARNING

Risk of personal injury due to incorrect removal of the anti-rotation fixture under tension.

Once the actuator has been mounted on the valve and the assembly is ready for use, the clamps (301) of the anti-rotation fixture on the plug stem are under tension.

- Follow the instructions in this document during mounting or removal.
- Do not loosen the screws (303) of the anti-rotation fixture while the force generated by the supply air and/or the actuator springs is transmitted to the actuator stem and the stem (9).
- First remove the actuator from the valve or ensure it cannot transmit any forces to the actuator stem before removing the anti-rotation fixture on the plug stem.

1. Lay out the necessary material and tools to have them ready for the service work.
2. Put the control valve out of operation (see the 'Decommissioning' section).
3. Remove the actuator from the valve. See associated actuator documentation.

Note

To remove an actuator with "stem extends" fail-safe action and/or with preloaded springs, a certain signal pressure must be applied to the actuator (see associated actuator documentation). Afterwards, the signal

pressure must be removed and the air supply disconnected again and locked.

Tip

We recommend removing the valve from the pipeline before performing any service work (see the 'Removal' section).

The following service work can be performed after preparation is completed:

- Replace the gaskets (see section 9.4.2)
- Replace the packing (see section 9.4.3)
- Replace the seat and plug (see section 9.4.4)

9.3 Installing the valve after service work

1. Mount actuator. See associated actuator documentation and the 'Installation' section.
2. Adjust lower or upper signal bench range. See associated actuator documentation.
3. If the valve has been removed, re-install the valve into the pipeline (see the 'Installation' section).
4. Put the control valve back into operation (see the 'Start-up' section). Observe the requirements and conditions for start-up or putting the valve back into operation.

9.4 Service work

- Before performing any service work, preparations must be made to the control valve (see section 9.2).
- After all service work is completed, check the control valve before putting it back into operation (see 'Testing the installed valve' in the 'Installation' section).

i Note

In versions with flow divider, it takes over the function as a seat retainer (124), i.e. the seat (4) is clamped in place by the flow divider (62).

9.4.1 Checking facings

As part of the service work (section 9.4.2 to 9.4.4), check the facings at the valves. Fig. 9-1 shows all the facings at the valve.

- Make sure that the facings are free of dirt and not damaged.

9.4.2 Replacing the gaskets

! NOTICE

Risk of control valve damage due to incorrect servicing.

- *The gaskets can only be replaced when all the following conditions are met:*
 - *The valve does not have a balanced plug.*
 - *The valve does not have a bellows seal.*
 - *To replace the gaskets in other valve versions, contact our after-sales service.*
-

The following gaskets are installed and must be exchanged:

- Gasket (17)
 - Shim (125)
 - Seat retainer gasket (126)
- Measure how many shims (125) and gaskets (126) are required as described in section 9.4.5.
 - Make sure that the gaskets are free of dirt and not damaged.
 - Make sure that the inserted gaskets rest with their entire surface on the facing.
-

i Note

Proceed as follows to service versions with the standard bonnet (2). The same procedure applies to versions with insulating section (21).

1. Undo the body nuts (14) gradually in a crisscross pattern.
2. Lift the yoke (60), bonnet (2) and plug with plug stem (5) off the body (1).
3. Remove the gasket (17), shims (125) and gaskets (126).
4. Carefully clean the facings (DF 3, DF 4, DF 5, DF 6, DF 8 and DF 9).
5. Measure how many gaskets (126) are required as described in section 9.4.5. Insert new gaskets (126) into the groove of the seat retainer (124). See Fig. 9-2.
6. Measure how many shims (125) are required as described in section 9.4.5. Place the new shims (125) on the gaskets (126). See Fig. 9-3.

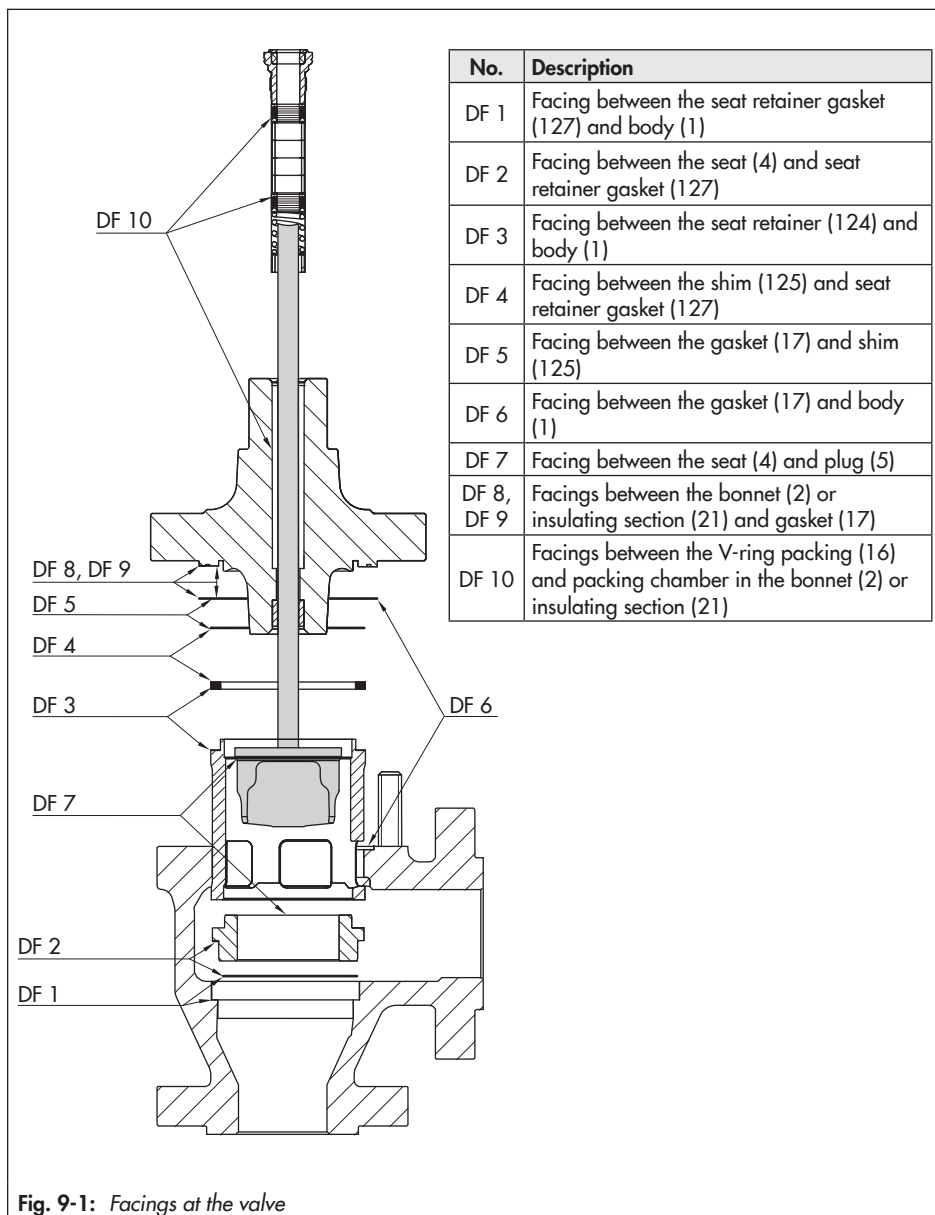

Fig. 9-1: Facings at the valve

NPS 6 and larger: place the gaskets (126) and shims (125) in alternating order into the groove of the seat retainer (124).

Make sure the shims do not touch the facing (DF 6) of the body anywhere.

7. Insert the new gasket (17) into the groove of the seat retainer (124) and body (1). See Fig. 9-4.

8. Place yoke (60), bonnet (2) with plug and plug stem (5) onto the body (1). Make sure that an opening of the seat retainer (124) faces toward the valve outlet.

Version with V-port plug: place the bonnet onto the valve body, making sure that the largest V-shaped port of the V-port plug faces towards the valve outlet.

Version with perforated plug: place the bonnet onto the valve body, making sure that the hole of the plug that releases the flow first faces toward the valve outlet.

See relevant information under 'Mounting the actuator onto the valve' in the 'Installation' section.

9. Firmly press the plug (5) into the seat (4). Fasten down the bonnet (2) with the body nuts (14). See section 9.4.6.

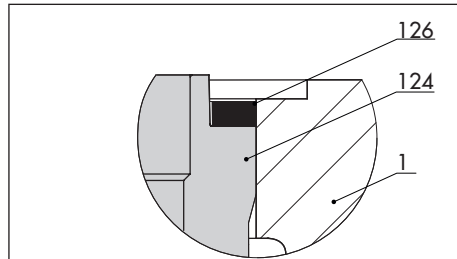

Fig. 9-2: Gasket (126)

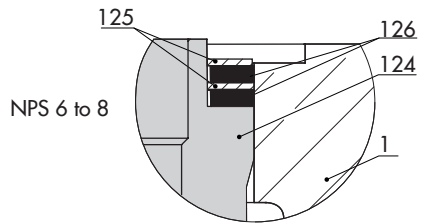
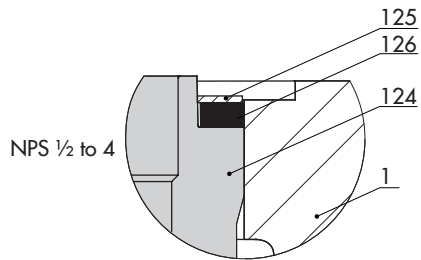

Fig. 9-3: Shims (125)

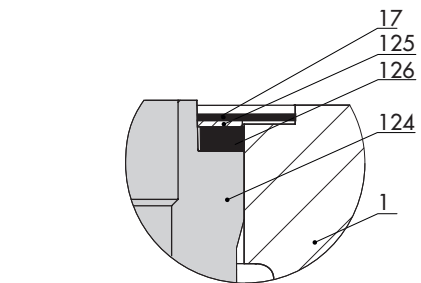
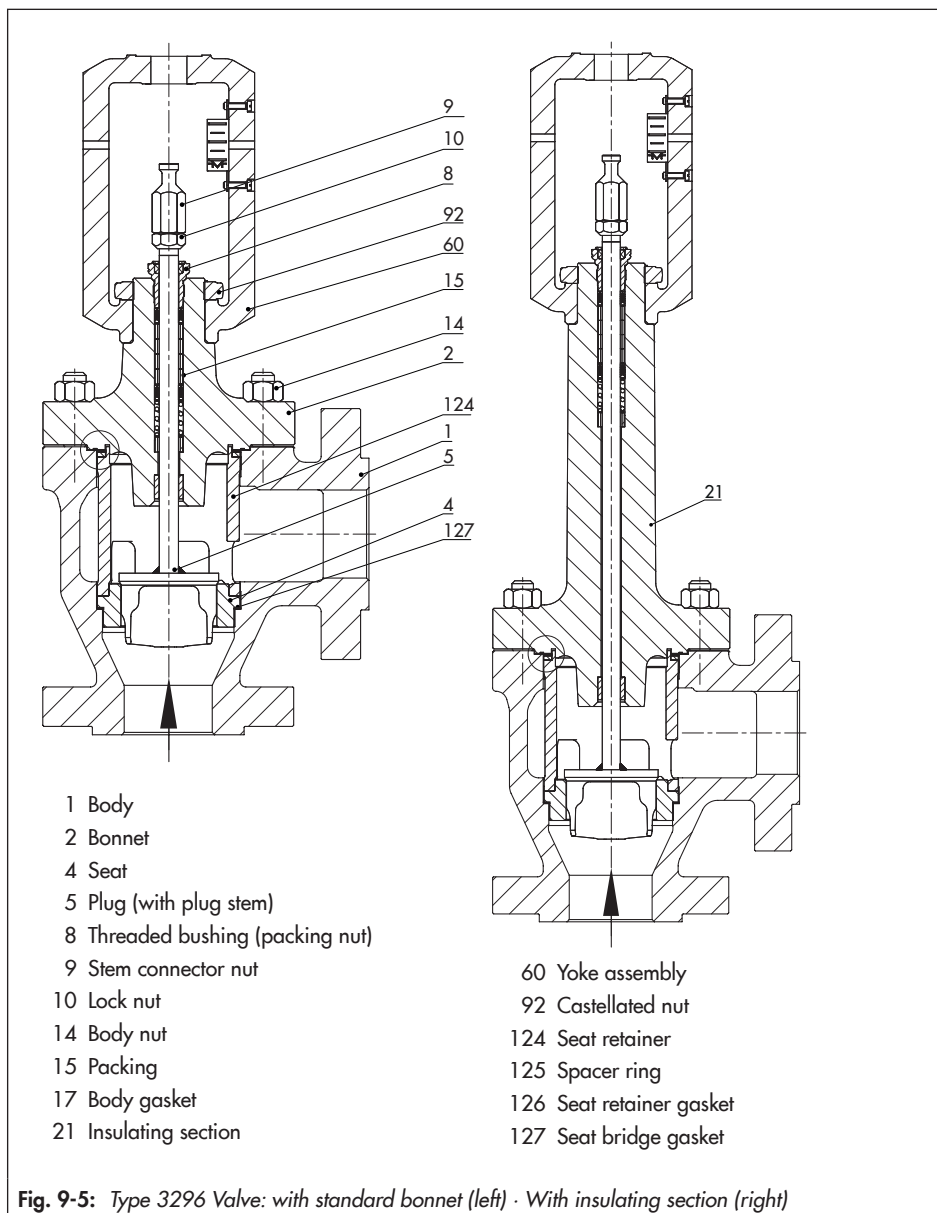

Fig. 9-4: Gasket (17)



9.4.3 Replacing the packing

NOTICE

Risk of control valve damage due to incorrect servicing.

- The packing can only be replaced when all the following conditions are met:
- The valve does not have a balanced plug.
 - The valve does not have a bellows seal.
 - The standard, form HT or ADSEAL packing is installed in the valve.
- To replace the packing in other valve versions, contact our after-sales service.

a) Standard packing (PTFE)

1. Unscrew the castellated nut (92) and take the yoke (60) off the bonnet (2).
2. Undo the body nuts (14) gradually in a crisscross pattern.
3. Lift the bonnet (2) and plug with plug stem (5) off the body (1).
4. Replace the gaskets (see section 9.4.2).
5. Unscrew the stem connector nut (9) and lock nut (10) from the plug stem.
6. Unscrew the threaded bushing (8).
7. Pull the plug with plug stem (5) out of the bonnet (2).
8. Pull the entire packing out of the packing chamber using a suitable tool.
9. Renew damaged parts. Carefully clean the facing (DF 10) in the packing chamber.
10. Apply a suitable lubricant to all the packing parts and to the plug stem (5).
11. Slide the plug with plug stem (5) into the bonnet (2).
12. Make sure that the seat (4) and seat retainer (124) are still clamped correctly on the body.
13. Place the bonnet (2) together with the plug stem and plug (5) onto the body. Make sure that an opening of the seat retainer (124) faces toward the valve outlet.

Version with V-port plug: place the bonnet onto the valve body, making sure that the largest V-shaped port of the V-port plug faces towards the valve outlet.

Version with perforated plug: place the bonnet onto the valve body, making sure that the hole of the plug that releases the flow first faces toward the valve outlet.

See relevant information under 'Mounting the actuator onto the valve' in the 'Installation' section.

14. Carefully slide the packing parts over the plug stem into the packing chamber using a suitable tool. Observe the proper sequence (see Fig. 9-6).
15. Firmly press the plug (5) into the seat (4). Fasten down the bonnet (2) with the body nuts (14). See section 9.4.6.
16. Screw in the threaded bushing (8) and tighten it. Observe tightening torques.
17. Place yoke (60) on the bonnet (2) and fasten using the castellated nut (92).

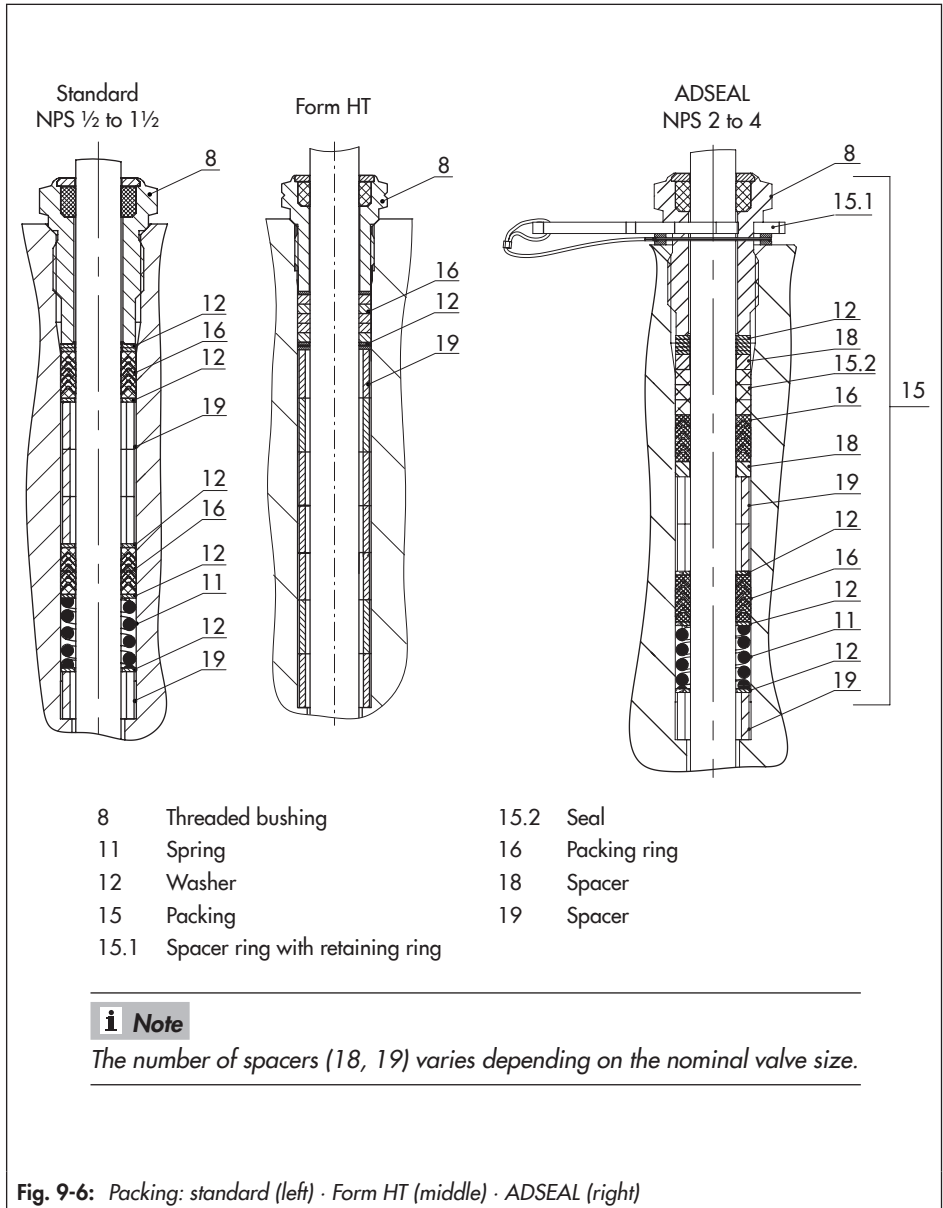

Servicing

18. Loosely screw the lock nut (10) and stem connector nut (9) onto the plug stem.

b) Form HT packing

! NOTICE

Damage to the packing (form HT) through the use of lubricant.

The form HT packing contains graphite.

→ *Do not use any lubricant during the installation of this packing.*

1. Proceed as described in 'Standard packing (PTFE)', steps 1 to 14. Do not use any lubricant.
2. To compress the packing, tighten the packing until reaching the metal stop using a suitable tool.
3. Remove the tool.
4. Proceed as described in 'Standard packing (PTFE)', steps 15 to 18.
5. Stroke the plug stem (5) up and down around ten times to allow the packing to settle.

c) ADSEAL packing

1. Proceed as described in 'Standard packing (PTFE)', steps 1 to 13.
2. Carefully slide the packing parts over the plug stem into the packing chamber using a suitable tool. Observe the proper sequence (see Fig. 9-6).
3. Slide the seals (15.2) over the plug stem.

Insert the wire of the red spacer ring (15.1) into the groove of the retaining ring.

Slide the retaining ring over the plug stem.

4. Insert the red spacer ring (15.1) between the threaded bushing (8) and retaining ring. See Fig. 9-6.
5. Proceed as described in 'Standard packing (PTFE)', steps 15 to 18.

9.4.4 Replacing the seat and plug

! NOTICE

Risk of control valve damage due to incorrect servicing.

→ *Seat and plug can only be replaced when all the following conditions are met:*

- *The valve does not have a balanced plug.*
- *The valve does not have a bellows seal.*
- *The standard, form HT or ADSEAL packing is installed in the valve.*

→ *To replace seat and plug in other valve versions, contact our after-sales service.*

! NOTICE

Risk of damage to the facing of the seat and plug due to incorrect servicing.

→ *Always replace both the seat and plug.*

i Note

In versions with flow divider, it takes over the function as a seat retainer (124), i.e. the seat (4) is clamped in place by the flow divider (62).

1. Unscrew the castellated nut (92) and take the yoke (60) off the bonnet (2).
2. Undo the body nuts (14) gradually in a crisscross pattern.
3. Lift the bonnet (2) and plug with plug stem (5) off the body (1).
4. Remove gaskets and replace with new ones (see section 9.4.2), if necessary.
5. Unscrew the stem connector nut (9) and lock nut (10) from the plug stem.
6. Unscrew the threaded bushing (8).
7. Pull the plug with plug stem (5) out of the bonnet (2).
8. Pull the entire packing out of the packing chamber using a suitable tool.
We recommend replacing the packing as well. See section 9.4.3.
9. Make sure that the guide bushing (7) is not damaged. If necessary, replace the guide bushing using a suitable tool.
10. Remove the seat (4) and seat retainer (124).
11. Remove the gasket (127).
12. Carefully clean the facings (DF 1, DF 2, DF 3 and DF 7).
13. Insert a new gasket (127) into the seat bridge.

14. Carefully place the new seat (4) in the body (1) and use the seat retainer (124) to clamp it into position. Align the seat retainer in such a way that an opening faces toward the valve outlet.

15. Insert gaskets (see section 9.4.2).
16. Slide the new plug with plug stem (5) into the bonnet (2).
17. Place the bonnet (2) together with the plug stem and plug (5) onto the body.

Version with V-port plug: place the bonnet onto the valve body, making sure that the largest V-shaped port of the V-port plug faces towards the valve outlet.

Version with perforated plug: place the bonnet onto the valve body, making sure that the hole of the plug that releases the flow first faces toward the valve outlet.

See relevant information under 'Mounting the actuator onto the valve' in the 'Installation' section.

18. Carefully slide the packing parts over the plug stem into the packing chamber using a suitable tool. Observe the proper sequence (see Fig. 9-6).
19. Firmly press the plug (5) into the seat (4). Fasten down the bonnet (2) with the body nuts (14). See section 9.4.6.
20. Screw in the threaded bushing (8) and tighten it. Observe tightening torques.
21. Place yoke (60) on the bonnet (2) and fasten using the castellated nut (92).
22. Loosely screw the lock nut (10) and stem connector nut (9) onto the plug stem.

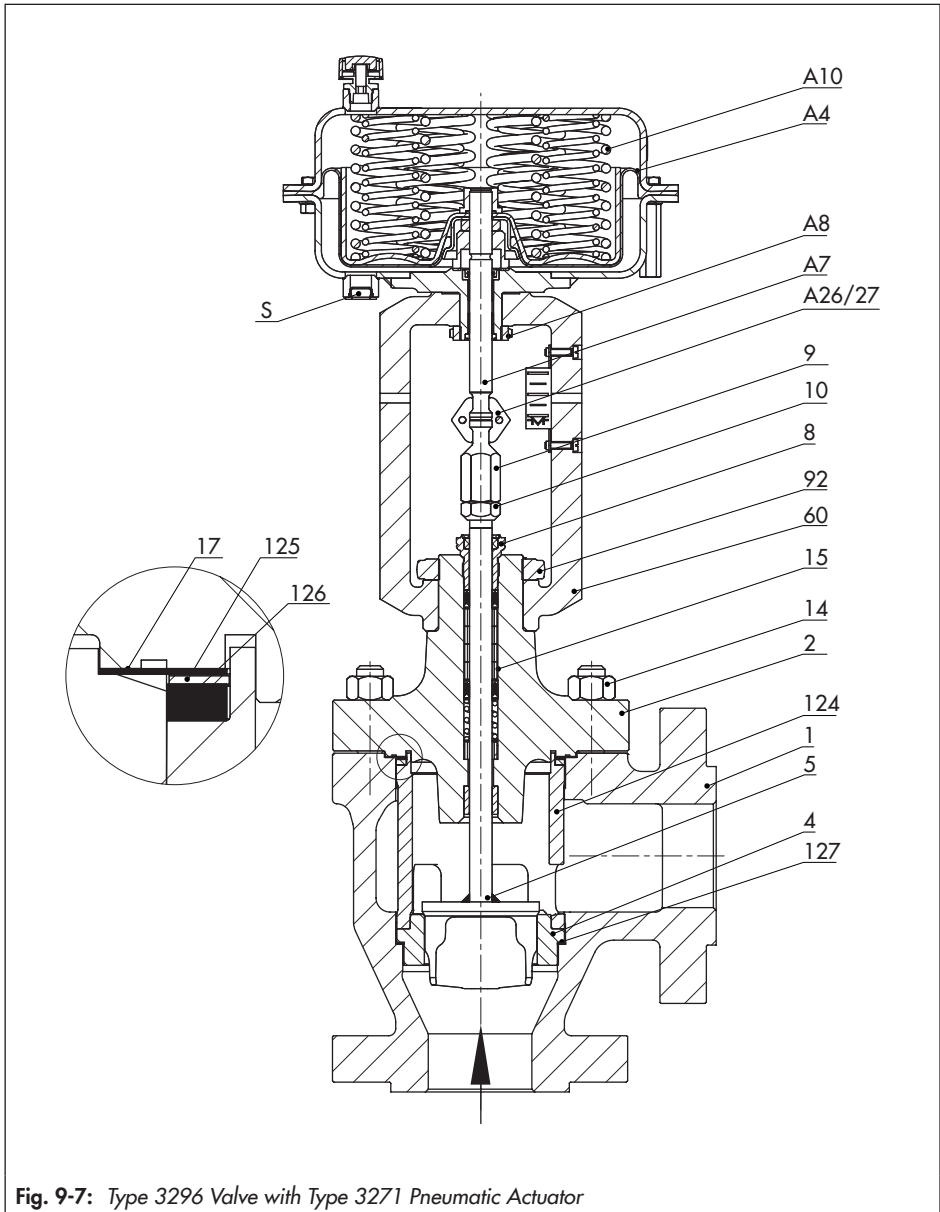

Fig. 9-7: Type 3296 Valve with Type 3271 Pneumatic Actuator

1 Body	124 Seat retainer
2 Bonnet	125 Spacer ring
4 Seat	126 Seat retainer gasket
5 Plug (with plug stem)	127 Seat bridge gasket
8 Threaded bushing (packing nut)	A4 Diaphragm
10 Lock nut	A7 Actuator stem
14 Body nut	A8 Ring nut
15 Packing	A10 Spring
17 Body gasket	A26/27 Stem connector clamps
60 Yoke assembly	S Signal pressure connection
92 Castellated nut	

9.4.5 Determining the number of gaskets required

The following gaskets are installed and must be exchanged:

- Gasket (17)
- Shim (125)
- Seat retainer gasket (126)

Determining height H1

H1 is the height between the facing of the seat retainer (124) and the facing of the body (1). See Fig. 9-8.

1. Measure H1 at three places evenly distributed around the circumference of the body.
2. Write down the measured values 1 to 3 in Table 9-1. Calculate the average value and enter it as $H1_{actual}$.
3. Calculate the difference ΔH from the target dimension $H1_{target}$ and actual dimension $H1_{actual}$ and write it down.

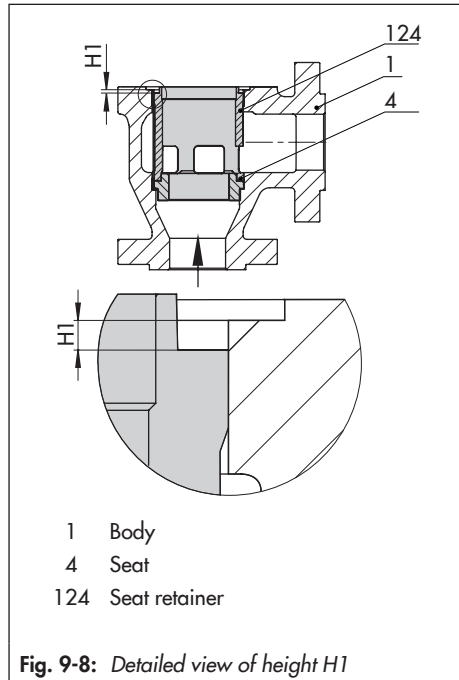

Fig. 9-8: Detailed view of height H1

Table 9-1: Determining height H1 · Dimensions in mm

NPS	$H1_{target}$	H1 (value 1)	H1 (value 2)	H1 (value 3)	$H1_{actual}$	$\Delta H = H1_{target} - H1_{actual}$
½ to 1	4.8					
1½	5.1					
2	5.1					
3	5.1					
4	5.1					
6	9.9					
8	10.1					

Determining height H2

H2 is the height of the new gasket(s) (126) at the seat retainer (124). See Fig. 9-9.

1. Measure H2 at three places evenly distributed around the circumference.
2. Write down the measured values 1 to 3 in Table 9-2. Calculate the average value and enter it as $H2_{actual}$.
3. Insert the gasket (126). See section 9.4.2.

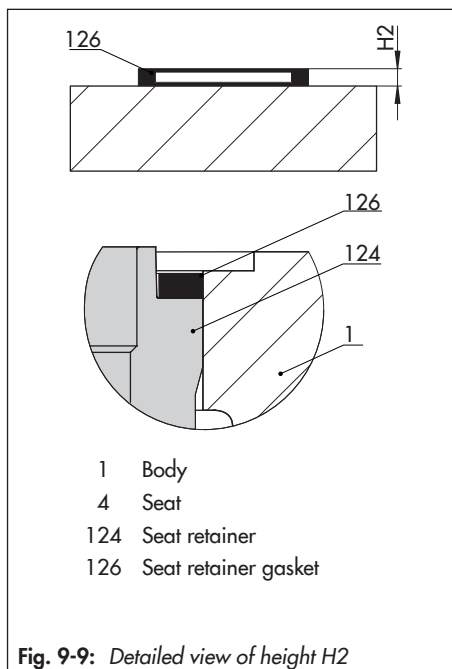

Table 9-2: Determining height H2 · Dimensions in mm

Gasket number (one gasket up to NPS 4, two gaskets for NPS 6 or larger)	H2 (value 1)	H2 (value 2)	H2 (value 3)	$H2_{actual}$

Selecting the shims

t_{total} is the height of the required shims.

1. Calculate the height t_{total} based on the previously determined values (see Table 9-1 and Table 9-2) and enter it into Table 9-3.
2. Insert shims (125). See section 9.4.2.

i Note

Use only one shim and one gasket to compensate for the height difference in valves up to NPS 4. Install two shims and two gaskets in alternating order in valves larger than NPS 6.

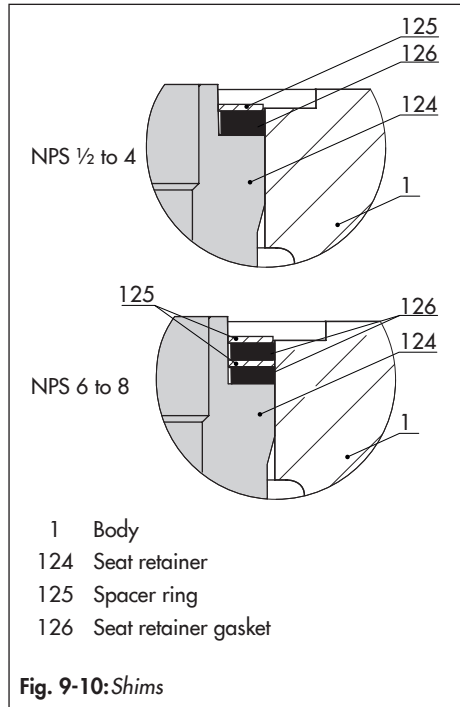

Table 9-3: Selecting the shims

NPS	Height T	Tolerance	Ideal height t_{total}	No. of shims
1/2 to 1	$6.1 - \Delta H - H2_{actual}$	-0.1		1
1 1/2				
2				
3				
4	$12.1 - \Delta H - H2_{actual_total}$	-0.1		2
6				
8				

9.4.6 Tightening the body nuts

NOTICE

Risk of valve damage due to excessively high or low tightening torques.

Observe the specified torques when tightening control valve components. Excessive tightening torques lead to parts wearing out more quickly. Parts that are too loose may cause leakage.

→ Observe the specified tightening torques (▶ AB 0100).

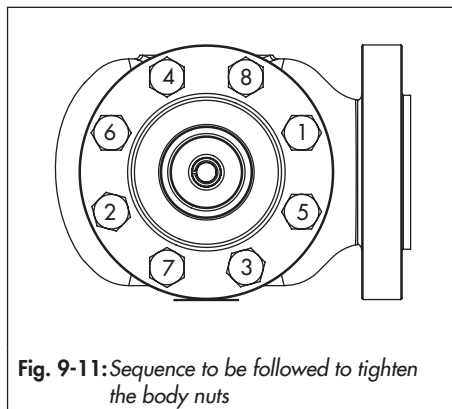

Fig. 9-11: Sequence to be followed to tighten the body nuts

It is not enough to just tighten the body nuts (14) once as the gasket (126) underneath the shim (125) yields. On tightening the body nuts on the bonnet (2) or insulating section (21), proceed as follows:

1. Tighten the body nuts gradually in a crisscross pattern (applying half of the specified tightening torque).
2. Tighten the body nuts in a crisscross pattern several times until no further rotary motion occurs.
3. Tighten the body nuts gradually in a crisscross pattern (applying 75 % of the specified tightening torque).
4. Tighten the body nuts in a clockwise pattern with the full tightening torque.

9.5 Ordering spare parts and operating supplies

Contact your nearest SAMSON subsidiary or SAMSON's After-sales Service for information on spare parts, lubricants and tools.

Spare parts

See Annex for details on spare parts.

Lubricant

See document ► AB 0100 for details on suitable lubricants.

Tools

See document ► AB 0100 for details on suitable tools.

10 Decommissioning

The work described in this section is only to be performed by personnel appropriately qualified to carry out such tasks.

⚠ DANGER

Risk of bursting due to incorrect opening of pressurized equipment or components.

Valves and pipelines are pressure equipment that may burst when handled incorrectly.

Flying projectile fragments or the release of process medium under pressure can cause serious injury or even death.

Before working on the control valve:

- Depressurize all plant sections affected and the valve (including the actuator). Release any stored energy.
- Drain the process medium from all the plant sections concerned as well as the valve.

⚠ WARNING

Risk of burn injuries due to hot or cold components and pipeline.

Valve components and the pipeline may become very hot or cold. Risk of burn injuries.

- Allow components and pipelines to cool down or warm up to the ambient temperature.
- Wear protective clothing and safety gloves.

⚠ WARNING

Risk of personal injury due to pressurized components and process medium being discharged.

- Do not loosen the screw of the test connection while the valve is pressurized.

⚠ WARNING

Risk of hearing loss or deafness due to loud noise.

Noise emission (e.g. cavitation or flashing) may occur during operation caused by the process medium and the operating conditions. Additionally, a loud noise may briefly occur through the sudden venting of the pneumatic actuator or pneumatic valve accessories not fitted with noise-reducing fittings. Both can damage hearing.

- Wear hearing protection when working near the valve.

⚠ WARNING

Crush hazard arising from actuator and plug stem moving.

- Do not insert hands or finger into the yoke while the air supply is connected to the actuator.
- Before working on the control valve, disconnect and lock the pneumatic air supply as well as the control signal.
- Do not impede the movement of the actuator and plug stem by inserting objects into the yoke.
- Before unblocking the actuator and plug stem after they have become blocked

Decommissioning

(e.g. due to seizing up after remaining in the same position for a long time), release any stored energy in the actuator (e.g. spring compression). See associated actuator documentation.

WARNING

Risk of personal injury due to exhaust air being vented.

While the valve is operating, air is vented from the actuator, for example, during closed-loop operation or when the valve opens or closes.

→ Wear eye protection when working in close proximity to the control valve.

WARNING

Risk of personal injury due to residual process medium in the valve.

While working on the valve, residual medium can flow out of the valve and, depending on its properties, cause personal injury, e.g. (chemical) burns.

→ Wear protective clothing, safety gloves, respiratory protection and eye protection.

To decommission the control valve for service work or to remove it from the pipeline, proceed as follows:

1. Close the shut-off valves upstream and downstream of the control valve to stop the process medium from flowing through the valve.

2. Completely drain the pipelines and valve.
3. Disconnect and lock the pneumatic air supply to depressurize the actuator.
4. Release any stored energy.
5. If necessary, allow the pipeline and valve components to cool down or warm up to the ambient temperature.

11 Removal

The work described in this section is only to be performed by personnel appropriately qualified to carry out such tasks.

⚠ WARNING

Risk of burn injuries due to hot or cold components and pipeline.

Valve components and the pipeline may become very hot or cold. Risk of burn injuries.

- Allow components and pipelines to cool down or warm up to the ambient temperature.
- Wear protective clothing and safety gloves.

⚠ WARNING

Crush hazard arising from actuator and plug stem moving.

- Do not insert hands or finger into the yoke while the air supply is connected to the actuator.
- Before working on the control valve, disconnect and lock the pneumatic air supply as well as the control signal.
- Do not impede the movement of the actuator and plug stem by inserting objects into the yoke.
- Before unblocking the actuator and plug stem after they have become blocked (e.g. due to seizing up after remaining in the same position for a long time), release any stored energy in the actuator (e.g. spring compression). See associated actuator documentation.

⚠ WARNING

Risk of personal injury due to residual process medium in the valve.

While working on the valve, residual medium can flow out of the valve and, depending on its properties, cause personal injury, e.g. (chemical) burns.

- Wear protective clothing, safety gloves, respiratory protection and eye protection.

⚠ WARNING

Risk of personal injury due to preloaded springs.

Actuators with preloaded springs are under tension. They can be identified by the long bolts protruding from the bottom of the actuator.

- Before starting any work on the actuator, relieve the compression from the preloaded springs.

⚠ WARNING

Risk of personal injury due to incorrect removal of the anti-rotation fixture under tension.

Once the actuator has been mounted on the valve and the assembly is ready for use, the clamps (301) of the anti-rotation fixture on the plug stem are under tension.

- Follow the instructions in this document during mounting or removal.
- Do not loosen the screws (303) of the anti-rotation fixture while the force generated by the supply air and/or the actuator

Removal

springs is transmitted to the actuator stem and the stem (9).

- *First remove the actuator from the valve or ensure it cannot transmit any forces to the actuator stem before removing the anti-rotation fixture on the plug stem.*
-

Before removing the valve, make sure the following conditions are met:

- The control valve is put out of operation (see the 'Decommissioning' section).

11.1 Removing the valve from the pipeline

a) Version with flanges

1. Support the valve to hold it in place when separated from the pipeline (see the 'Shipment and on-site transport' section).
2. Unbolt the flange joint.
3. Remove the valve from the pipeline (see the 'Shipment and on-site transport' section).

b) Version with welding ends

1. Support the valve to hold it in place when separated from the pipeline (see the 'Shipment and on-site transport' section).
2. Cut the pipeline in front of the weld seam.

3. Remove the valve from the pipeline (see the 'Shipment and on-site transport' section).

11.2 Removing the actuator from the valve

See associated actuator documentation.

12 Repairs

If the valve does not function properly according to how it was originally sized or does not function at all, it is defective and must be repaired or exchanged.

! NOTICE

Risk of valve damage due to incorrect service or repair work.

- ➔ *Do not perform any repair work on your own.*
- ➔ *Contact SAMSON's After-sales Service for repair work.*

12.1 Returning devices to SAMSON

Defective devices can be returned to SAMSON for repair.

Proceed as follows to return devices:

1. Exceptions apply concerning some special device models
 - ▶ www.samsongroup.com > Service & Support > After-sales Service.
2. Send an e-mail
 - ▶ retouren@samsongroup.com to register the return shipment including the following information:
 - Type
 - Article no.
 - Configuration ID
 - Original order

- Completed Declaration on Contamination, which can be downloaded from our website at
 - ▶ www.samsongroup.com > Service & Support > After-sales Service.

After checking your registration, we will send you a return merchandise authorization (RMA).

3. Attach the RMA (together with the Declaration on Decontamination) to the outside of your shipment so that the documents are clearly visible.
4. Send the shipment to the address given on the RMA.

i Note

Further information on returned devices and how they are handled can be found at

- ▶ www.samsongroup.com > Service & Support > After-sales Service.

13 Disposal

- Observe local, national and international refuse regulations.
- Do not dispose of components, lubricants and hazardous substances together with your household waste.

14 Certificates

These declarations are included on the next pages:

- Declaration of conformity in compliance with Pressure Equipment Directive 2014/68/EU on page 14-2
- Declaration of conformity in compliance with Machinery Directive 2006/42/EC for Types 3296-1 and 3296-7 Control Valves on page 14-3
- Declaration of incorporation in compliance with Machinery Directive 2006/42/EC for the Type 3296 Valve with other actuators other than Types 3271 and 3277 Actuators on page 14-4

The certificates shown were up to date at the time of publishing. The latest certificates can be found on our website:

► www.samsongroup.com > *Products & Applications* > *Product selector* > *Valves* > *3296*

Other optional certificates are available on request.

EU DECLARATION OF CONFORMITY TRANSLATION



Module H / N° CE-0062-PED-H-SAM 001-20-DEU-rev-A

For the following products, SAMSON hereby declares under its sole responsibility:

Devices	Series	Type	Version
Globe valve	240	3241	DIN, body of cast iron from DN 150, body of spheroidal-graphite iron, from DN 100, fluids G2, L1, L2 ¹⁾ DIN/ANSI, body of steel, etc., all fluids
Three-way valve	240	3244	DIN, body of cast iron from DN 150, body of spheroidal-graphite iron, from DN 100, fluids G2, L1, L2 ¹⁾ DIN/ANSI, body of steel, etc., all fluids
Cryogenic valve	240	3248	DIN/ANSI, all fluids
Globe valve	250	3251	DIN/ANSI, all fluids
Globe valve	250	3251-E	DIN/ANSI, all fluids
Three-way valve	250	3253	DIN/ANSI, body of steel, etc., all fluids
Globe valve	250	3254	DIN/ANSI, all fluids
Angle valve	250	3256	DIN/ANSI, all fluids
Split-body valve	250	3258	DIN, all fluids
Angle valve (IG standards)	250	3259	DIN, all fluids
Steam-converting valve	280	3281	DIN/ANSI, all fluids
		3284	DIN/ANSI, all fluids
		3286	DIN/ANSI, all fluids
		3288	DIN, all fluids
Globe valve	V2001	3321	DIN, body of steel, etc., all fluids ANSI, all fluids
Three-way valve	V2001	3323	DIN, body of steel, etc., all fluids ANSI, all fluids
Angle seat valve	---	3353	DIN, body of steel, etc., all fluids
Silencer	3381	3381-1	DIN/ANSI, single attenuation plate with welding ends, all fluids
		3381-3	DIN/ANSI, all fluids
		3381-4	DIN/ANSI, single attenuation plate multi-stage with welding ends, all fluids
		3381-4	DIN/ANSI, single attenuation plate multi-stage with welding ends, all fluids
Globe valve	240	3241	ANSI, body of cast iron, Class 125, from NPS 5, fluids G2, L1, L2 ¹⁾
Cryogenic valve	240	3246	DIN/ANSI, all fluids
Three-way valve	250	3253	DIN, body of cast iron from DN200 PN16, fluids G2, L1, L2 ¹⁾
Globe valve	290	3291	ANSI, all fluids
Angle valve	290	3296	ANSI, all fluids
Globe valve	590	3591	ANSI, all fluids
Angle valve	590	3596	ANSI, all fluids
Cryogenic valve	590	3598	ANSI, NPS 3 to NPS 8, Class 900, all fluids
Control valve	---	3595	ANSI, all fluids

¹⁾ Gases according to Article 4(1)(c.i), second indent
Liquids according to Article 4(1)(c.ii)

that the products mentioned above comply with the requirements of the following standards:

Directive of the European Parliament and of the Council on the harmonization of the laws of the Member States relating to the making available on the market of pressure equipment	2014/68/EU	of 15 May 2014
Applied conformity assessment procedure for fluids according to Article 4(1)	Module H	by Bureau Veritas 0062

The manufacturer's quality management system is monitored by the following notified body:
Bureau Veritas Services SAS, 8 Cours du Triangle, 92800 PUTEAUX - LA DEFENSE
Technical standards applied: DIN EN12516-2, DIN EN12516-3, ASME B16.34

Manufacturer: SAMSON AG, Weismuellerstrasse 3, 60314 Frankfurt am Main, Germany
Frankfurt am Main, 7 April 2021

Dr. Andreas Wild
Chief Executive Officer (CEO)

Dr. Thomas Steckenreiter
Chief Technology Officer (CTO)

Revision 08

EU DECLARATION OF CONFORMITY TRANSLATION



Declaration of Conformity of Final Machinery

in accordance with Annex II, section 1.A. of the Directive 2006/42/EC

For the following products:

Types 3296-1/-7 Pneumatic Control Valves consisting of the Type 3296 Valve and Type 3271/Type 3277 Pneumatic Actuator

We hereby declare that the machinery mentioned above complies with all applicable requirements stipulated in Machinery Directive 2006/42/EC.

For product descriptions of the valve and actuator, refer to:

- Type 3296 Valve (ANSI): Mounting and Operating Instructions EB 8074
- Types 3271 and 3277 Actuators: Mounting and Operating Instructions EB 8310-X

Valve accessories (e.g. positioners, limit switches, solenoid valves, lock-up valves, supply pressure regulators, volume boosters and quick exhaust valves) are classified as machinery components in this declaration of conformity and do not fall within the scope of the Machinery Directive as specified in § 35 and § 46 of the Guide to Application of the Machinery Directive 2006/42/EC issued by the European Commission. In the SAMSON Manual H 02 titled "Appropriate Machinery Components for SAMSON Pneumatic Control Valves with a Declaration of Conformity of Final Machinery", SAMSON defines the specifications and properties of appropriate machinery components that can be mounted onto the above specified final machinery.

Referenced technical standards and/or specifications:

- VCI, VDMA, VGB: "Leitfaden Maschinenrichtlinie (2006/42/EG) – Bedeutung für Armaturen, Mai 2018" [German only]
- VCI, VDMA, VGB: "Zusatzdokument zum „Leitfaden Maschinenrichtlinie (2006/42/EG) – Bedeutung für Armaturen vom Mai 2018" [German only], based on DIN EN ISO 12100:2011-03

Comment:

Information on residual risks of the machinery can be found in the mounting and operating instructions of the valve and actuator as well as in the referenced documents listed in the mounting and operating instructions.

Persons authorized to compile the technical file:

SAMSON AG, Weismüllerstraße 3, 60314 Frankfurt am Main, Germany
Frankfurt am Main, 10 May 2020

i.V. Peter Arzbach
Director
Product Management

i.V. Peter Scheermesser
Director
Product Life Cycle Management and ETO
Development for Valves and Actuators

Revision no. 00

DECLARATION OF INCORPORATION TRANSLATION



Declaration of Incorporation in Compliance with Machinery Directive 2006/42/EC

For the following product:
Type 3296 Pneumatic Control Valve

We certify that the Type 3296 Pneumatic Control Valves are partly completed machinery as defined in the Machinery Directive 2006/42/EC and that the safety requirements stipulated in Annex I, 1.1.2, 1.1.3, 1.1.5, 1.3.2, 1.3.4 and 1.3.7 are observed. The relevant technical documentation described in Annex VII, part B has been compiled.

Products we supply must not be put into service until the final machinery into which it is to be incorporated has been declared in conformity with the provisions of the Machinery Directive 2006/42/EC.

Operators are obliged to install the products observing the accepted industry codes and practices (good engineering practice) as well as the mounting and operating instructions. Operators must take appropriate precautions to prevent hazards that could be caused by the process medium and operating pressure in the temperature regulator as well as by the signal pressure and moving parts.

The permissible limits of application and mounting instructions for the products are specified in the associated mounting and operating instructions; the documents are available in electronic form on the Internet at www.samsongroup.com.

For product descriptions refer to:

- Type 3296 Valve (ANSI): Mounting and Operating Instructions EB 8074

Referenced technical standards and/or specifications:

- VCI, VDMA, VGB: "Leitfaden Maschinenrichtlinie (2006/42/EG) – Bedeutung für Armaturen, Mai 2018" [German only]
- VCI, VDMA, VGB: "Zusatzdokument zum Leitfaden Maschinenrichtlinie (2006/42/EG) – Bedeutung für Armaturen vom Mai 2018" [German only], based on DIN EN ISO 12100:2011-03

Comments:

- See mounting and operating instructions for residual hazards.
- Also observe the referenced documents listed in the mounting and operating instructions.

Persons authorized to compile the technical file:

SAMSON AG, Weismüllerstraße 3, 60314 Frankfurt am Main, Germany
Frankfurt am Main, 10 May 2021

Peter Arzbach
Director
Product Management

Peter Scheermesser
Director
Product Life Cycle Management and
ETO Development for Valves and Actuators

Revision no. 00

15 Annex

15.1 Tightening torques, lubricants and tools

- ▶ AB 0100 for tools, tightening torques and lubricants

15.2 Spare parts

Shims (125)

The shims are delivered as a set of seven shims with varying thickness (ranging from 0.7 to 1.25 mm).



Tip

Contact our after-sales service if you have any questions concerning the suitability of shim material.

Table 15-1: Item numbers to order shims

Shim material	NPS	Item no.
1.4404/A240 316L	½ to 1	1120-3074
	1½	1120-3075
	2	1120-3076
	3	1120-3077
	4	1120-3078
	6	1120-3079
	8	1120-3136
1.4301/A240 304	½ to 1	1120-3095
	1½	1120-3096
	2	1120-3097
	3	1120-3098
	4	1120-3099
	6	1120-3100
	8	1120-3137

Shim material	NPS	Item no.
2.4819/B574 N10276	½ to 1	1120-3311
	1½	1120-3312
	2	1120-3313
	3	1120-3314
	4	1120-3315
	6	1120-3316
	8	1120-3317
2.4610/B574 N06455	½ to 1	1120-3387
	1½	1120-3388
	2	1120-3389
	3	1120-3390
	4	1120-3391
	6	1120-3392
	8	1120-3393

List of valve spare parts

1	Body	39	Gasket (bonnet)
2	Bonnet	42	Screw plug (test connection)
3	Yoke	43	Seal
4	Seat	44	Ring (pressure balancing)
5	Plug (with plug stem)	45	Gasket (pressure balancing)
6	Nut	46	Gasket (pressure balancing)
7	Guide bushing	47	Support (pressure balancing)
8	Threaded bushing (packing nut)	48	Hex screw (pressure balancing)
9	Stem connector nut	49	Hex screw (pressure balancing)
10	Lock nut	50	Washer (pressure balancing)
11	Spring	51	Guide ring (several guides only for version with graphite seal)
12	Washer	52	Ring (pressure balancing)
13	Stud bolt	53	Retaining ring (pressure balancing)
14	Body nut	60	Yoke assembly
15	Packing	80	Nameplate
16	V-ring packing	81	Grooved pin
17	Body gasket	82	Screw
19	Bushing	83	Hanger
21	Insulating section	84	Travel indicator scale
22	Bellows seal	85	Screw
24	Guide bushing	91	Protective cap
26	Label	92	Castellated nut
27	Flange	101	Bellows cover
28	Clamping ring	102	Retaining ring
29	Plug for version with bellows seal	124	Seat retainer
31	Washer	125	Spacer ring
32	Screw	126	Seat retainer gasket
33	Nut	127	Seat bridge gasket
34	Screw		
37	Plug stem with metal bellows		

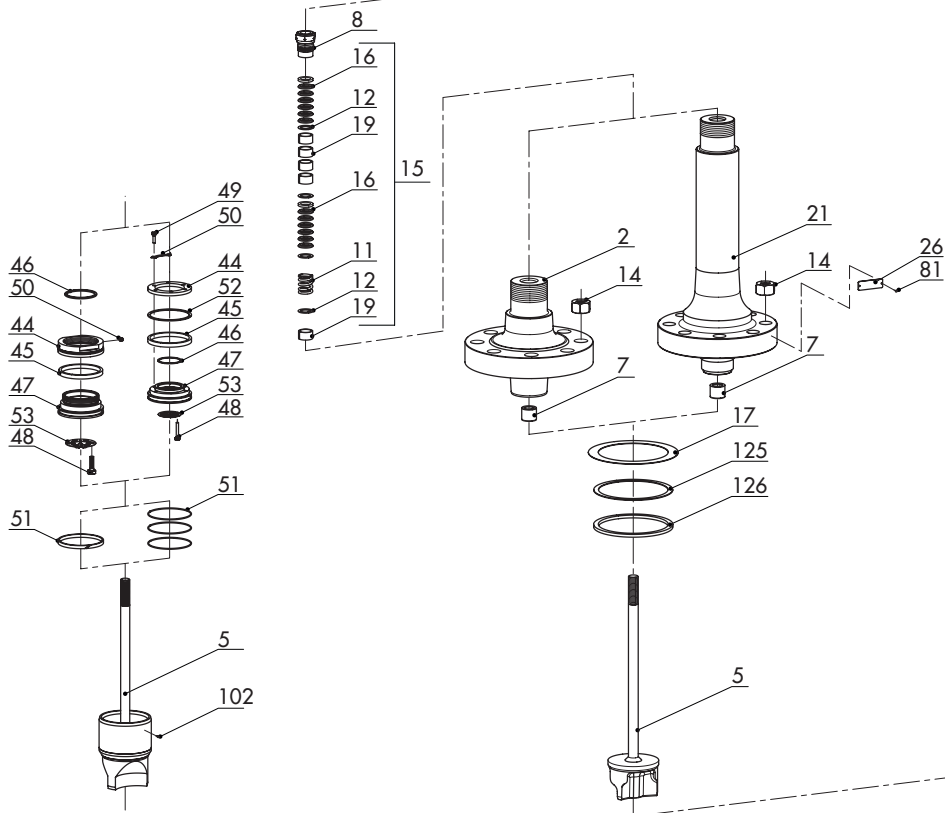
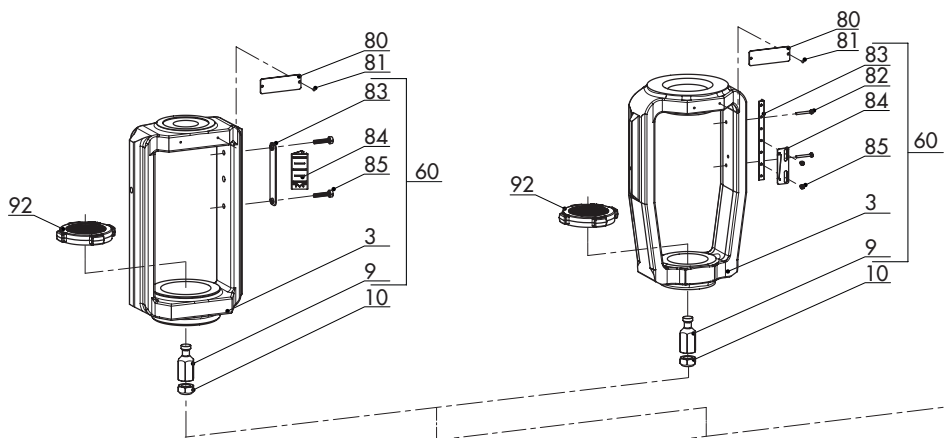

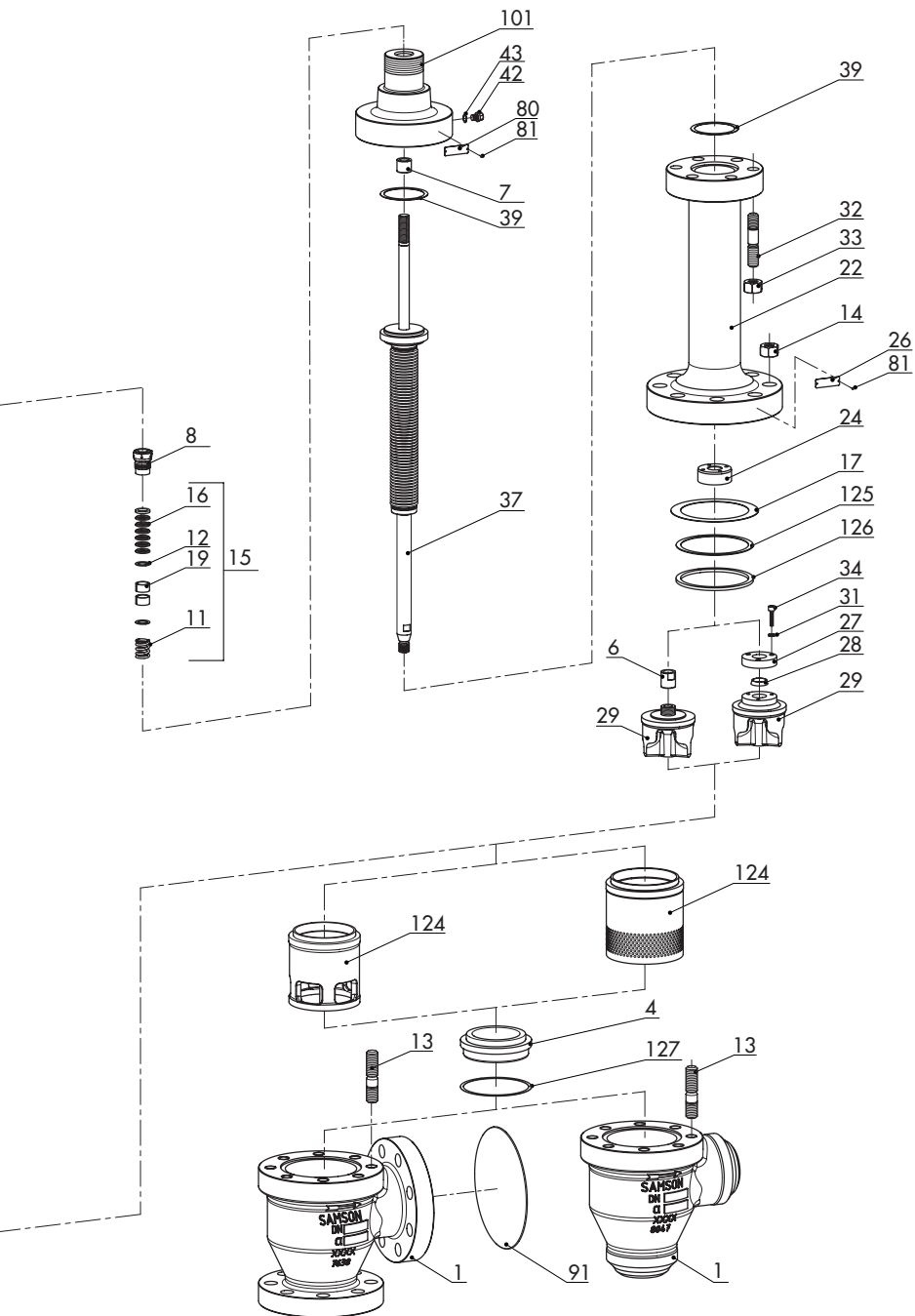

15.3 After-sales service

Contact our after-sales service for support concerning service or repair work or when malfunctions or defects arise.

E-mail address

You can reach our after-sales service at aftersalesservice@samsongroup.com.

Addresses of SAMSON AG and its subsidiaries

The addresses of SAMSON AG, its subsidiaries, representatives and service facilities worldwide can be found on our website (www.samsongroup.com) or in all SAMSON product catalogs.

Required specifications

Please submit the following details:

- Order number and position number in the order
- Type, model number, valve size and valve version
- Pressure and temperature of the process medium
- Flow rate in cu.ft./min or m³/h
- Bench range of the actuator (e.g. 0.2 to 1 bar)
- Is a strainer installed?
- Installation drawing

EB 8074 EN



SAMSON AKTIENGESELLSCHAFT
Weismüllerstraße 3 · 60314 Frankfurt am Main, Germany
Phone: +49 69 4009-0 · Fax: +49 69 4009-1507
samson@samsongroup.com · www.samsongroup.com