

MOUNTING AND OPERATING INSTRUCTIONS



EB 6493 EN

Translation of original instructions



TROVIS 6493 Compact Controller

Firmware version 4.03



Edition August 2021

Note on these mounting and operating instructions

These mounting and operating instructions assist you in mounting and operating the device safely. The instructions are binding for handling SAMSON devices. The images shown in these instructions are for illustration purposes only. The actual product may vary.

- For the safe and proper use of these instructions, read them carefully and keep them for later reference.
- If you have any questions about these instructions, contact SAMSON's After-sales Service (aftersaleservice@samsongroup.com).



Documents relating to the device, such as the mounting and operating instructions, are available on our website at www.samsongroup.com > **Service & Support > Downloads > Documentation.**

Definition of signal words

DANGER

Hazardous situations which, if not avoided, will result in death or serious injury

WARNING

Hazardous situations which, if not avoided, could result in death or serious injury

NOTICE

Property damage message or malfunction

Note

Additional information

Tip

Recommended action

1	Safety instructions and measures	1-1
1.1	Notes on possible severe personal injury	1-3
1.2	Notes on possible property damage	1-4
2	Markings on the device	2-1
2.1	Housing inscription	2-1
2.2	Article code	2-2
2.3	Firmware versions	2-2
3	Design and principle of operation	3-1
3.1	Technical data	3-5
3.2	Dimensions	3-8
3.3	Values for resistance thermometers	3-9
4	Shipment and on-site transport	4-1
4.1	Accepting the delivered goods	4-1
4.2	Removing the packaging from the compact controller	4-1
4.3	Transporting the compact controller	4-1
4.4	Storing the compact controller	4-1
5	Installation	5-1
5.1	Installation conditions	5-1
5.2	Preparation for installation	5-1
5.3	Mounting the compact controller	5-1
5.4	Electrical connection	5-3
6	Operation	6-1
6.1	Device overview	6-1
6.2	Operating controls	6-2
6.3	Display	6-3
6.4	Infrared interface	6-4
7	Start-up and configuration at the device	7-1
7.1	Configuration	7-1
7.1.1	Configuring the compact controller	7-8
7.2	Entering the key number	7-14
7.3	Tuning the control parameters	7-18
7.3.1	Empirical tuning method	7-18
7.3.2	Tuning according to the Ziegler and Nichols method	7-19
7.3.3	-CO- TUNE: Start-up adaptation	7-23

Contents

8	Start-up and configuration with TROVIS-VIEW	8-1
8.1	Communication	8-1
8.1.1	Interface	8-1
8.1.2	Addressing	8-3
8.1.3	Communication readings on the display	8-3
8.2	Folders in TROVIS-VIEW	8-4
8.2.1	Identification	8-4
8.2.2	Operation	8-4
8.2.3	Functions and parameters	8-6
8.2.3.1	Control parameters [PAR]	8-7
8.2.3.2	Input [IN]	8-7
8.2.3.3	Set point [SETP]	8-9
8.2.3.4	Controller [CNTR]	8-9
8.2.3.5	Output [OUT]	8-9
8.2.3.6	Limit relays [ALRM]	8-9
8.2.3.7	Additional functions [AUX]	8-9
8.2.3.8	Start-up adaptation [TUNE]	8-10
8.2.3.9	Process data [I-O]	8-11
9	Operation	9-1
9.1	Setting the internal set point	9-1
9.2	Switchover between set points	9-1
9.3	Switching over to manual mode and changing the manipulated variable	9-3
9.4	AUX menu, -CO- ST.IN: Reset to default settings	9-3
9.5	AUX menu, -CO- VIEW: Set viewing angle of the display	9-4
9.6	I-O menu: Process data	9-4
9.6.1	-CO- CIN: Firmware version	9-4
9.6.2	-CO- S-No: Serial number	9-4
9.6.3	-CO- ANA: Show analog inputs and outputs	9-5
9.6.4	-CO- BIN: Show binary inputs and outputs	9-5
9.6.5	-CO- ADJ: Calibration of analog inputs and analog output	9-5
10	Malfunctions	10-1
10.1	Troubleshooting	10-1
10.2	Error messages generated by the compact controller	10-4
10.3	Emergency action	10-4
11	Servicing	11-1
12	Decommissioning	12-1
13	Removal	13-1

14	Repairs	14-1
14.1	Returning devices to SAMSON	14-1
15	Disposal.....	15-1
16	Certificates.....	16-1
17	Annex A (configuration guide)	17-1
17.1	Abbreviations	17-1
17.2	Configuration list.....	17-2
17.3	Configuration protocol.....	17-20
18	Annex B.....	18-1
18.1	Accessories	18-1
18.2	After-sales service	18-2

Contents

1 Safety instructions and measures

Intended use

The TROVIS 6493 Compact Controller is a digital controller to automate the industrial and process plants. The controller is suitable for controlling continuous, on/off or pulsing final control elements.

The controller is designed to operate under exactly defined conditions. Therefore, operators must ensure that the controller is only used in operating conditions that meet the specifications used for sizing the controller at the ordering stage. In case operators intend to use the controller in other applications or conditions than specified, contact SAMSON.

SAMSON does not assume any liability for damage resulting from the failure to use the device for its intended purpose or for damage caused by external forces or any other external factors.

→ Refer to the technical data for limits and fields of application as well as possible uses. See the 'Design and principle of operation' section.

Reasonably foreseeable misuse

The controller is not suitable for the following applications:

- Use outside the limits defined during sizing and by the technical data

Furthermore, the following activities do not comply with the intended use:

- Use of non-original spare parts
- Performing service and repair work not described

Qualifications of operating personnel

The controller must be mounted, started up, serviced and repaired by fully trained and qualified personnel only; the accepted industry codes and practices must be observed. According to these mounting and operating instructions, trained personnel refers to individuals who are able to judge the work they are assigned to and recognize possible hazards due to their specialized training, their knowledge and experience as well as their knowledge of the applicable standards.

Safety instructions and measures

Personal protective equipment

No personal protective equipment is required for the direct handling of the controller.

Revisions and other modifications

Revisions, conversions or other modifications of the product are not authorized by SAMSON. They are performed at the user's own risk and may lead to safety hazards, for example. Furthermore, the product may no longer meet the requirements for its intended use.

Warning against residual hazards

The controller has a direct effect on the final control element. To avoid personal injury or property damage, plant operators and operating personnel must prevent hazards that could be caused in the control valve by the process medium, the operating pressure, the signal pressure or by moving parts by taking appropriate precautions. Plant operators and operating personnel must observe all hazard statements, warning and caution notes in the referenced documents.

Responsibilities of the operator

Operators are responsible for proper use and compliance with the safety regulations. Operators are obliged to provide these mounting and operating instructions as well as the referenced documents to the operating personnel and to instruct them in proper operation. Furthermore, operators must ensure that operating personnel or third parties are not exposed to any danger.

Responsibilities of operating personnel

Operating personnel must read and understand these mounting and operating instructions as well as the referenced documents and observe the specified hazard statements, warnings and caution notes. Furthermore, operating personnel must be familiar with the applicable health, safety and accident prevention regulations and comply with them.

Referenced standards, directives and regulations

The TROVIS 6493 Compact Controller with a CE marking fulfills the requirements of the Directives 2014/30/EU and 2014/35/EU.

The TROVIS 6493 Compact Controller with a EAC marking fulfills the requirements of the Regulations TR CU 004/2011 and TR CU 020/2011.

The 'Certificates' section contains this declaration of conformity and TR CU certificate.

The controller is designed for use in low voltage installations.

→ For wiring, maintenance and repair, observe the relevant safety regulations.

Referenced documentation

The documentation for the TROVIS 6493 Compact Controller consists of the Mounting and Operating Instructions EB 6493 and the Configuration Manual ► KH 6493.

These mounting and operating instructions EB 6493 describe the installation, electrical wiring and operation of the controller. In addition, EB 6493 includes a list of all configuration settings.

The Configuration Manual KH 6495-2 ► KH 6493 describes the controller's functions in detail. The control modes are explained using examples of applications. The TROVIS-VIEW software is explained in detail in the Operating Instructions ► EB 6661.

1.1 Notes on possible severe personal injury

DANGER

Risk of fatal injury due to electric shock.

- Before connecting wiring, performing any work on the device or opening the device, disconnect the supply voltage and protect it against unintentional reconnection. Make sure that the contacts of the digital outputs are voltage-free.
- Only use power interruption devices that can be protected against unintentional reconnection of the power supply.
- Do not remove any covers to perform adjustment work on live parts.

1.2 Notes on possible property damage

! NOTICE

Risk of damage to the controller due to the supply voltage exceeding the permissible tolerances.

The controller is designed for use in low voltage installations.

- Observe the permissible tolerances of the supply voltage.

Controller damage caused by water.

The terminals and the controller housing are not protected against water (terminals: IP 00, housing: IP 30). Only the front panel of the controller is protected against water (IP 65) when installed properly.

- Protect the terminals and the controller housing against drops, sprays and jets of water.

Malfunction due to a configuration that does not meet the requirements of the application.

The controller is configured for specific applications by setting configuration items and parameters. Configuration and parameterization have a direct effect on final control elements.

- Perform the configuration for the specific application.

Manipulation of the configuration due to unauthorized access.

The controller can be protected against unauthorized access through entering a key number.

- Activate key number operation (see the 'Operation' section).
- Do not pass the (service) key number on to unauthorized persons. Keep it in a safe place inaccessible to unauthorized persons.

The operator keys can be protected against unauthorized access over a digital input.

- Lock the operator keys over a digital input (see the 'Operation' section).

2 Markings on the device

2.1 Housing inscription

The details on the device version are lasered onto the nameplate on the side of the compact controller housing.

The nameplate shown was up to date at the time of publication of this document. The nameplate on the device may differ from the one shown.

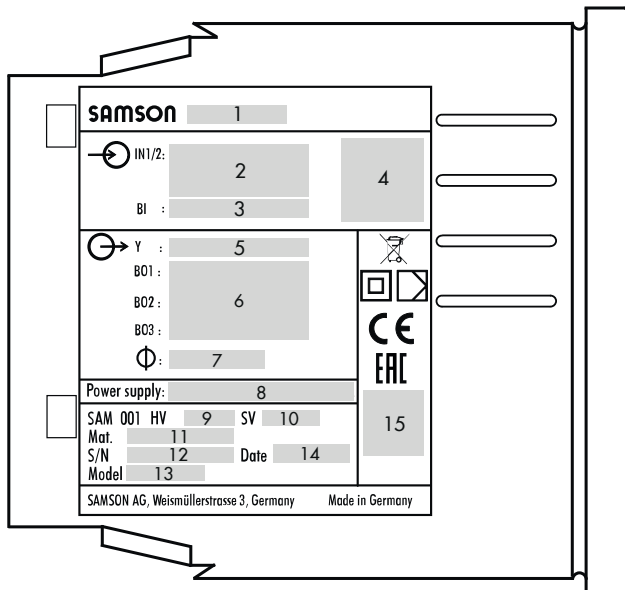

- | | | | |
|---|---|----|--------------------------|
| 1 | Type designation | 9 | Hardware version |
| 2 | Analog inputs 1 and 2 | 10 | Software version |
| 3 | Binary input | 11 | Material no. |
| 4 | Data Matrix code | 12 | Serial number |
| 5 | Analog output | 13 | Model number |
| 6 | Binary outputs 1 to 3 | 14 | Date of manufacture |
| 7 | Two-wire transmitter supply | 15 | Other mark of conformity |
| 8 | Supply voltage, power line frequency, power consumption | | |

2.2 Article code

TROVIS 6493-032 Compact Controller	x
---	---

Supply voltage	
----------------	--

90 to 250 V AC	4
----------------	---

24 V AC/DC	5
------------	---

2.3 Firmware versions

Firmware revisions	
Old	New
4.01	4.02
	Internal revisions
4.02	4.03
	Internal revisions

3 Design and principle of operation

The TROVIS 6493 Compact Controller is a panel-mounted digital controller to automate the industrial and process plants. It is suitable for control of continuous, on/off or pulsing final control elements (e.g. electro-pneumatic positioners, electric actuators, heating systems, refrigerating machines etc.)

The controller is configured to adapt it to control tasks. The controller settings are saved in a non-volatile memory, even when the power supply fails. It can be protected by a key number.

Control modes

The compact controller is designed for fixed set point and follow-up control. Two internal set points and one input for the external set point are available.

Default settings

The default compact controller is a temperature controller for fixed set point control with the internal set point **W** that operates as a PI controller.

The controlled variable is measured at the analog input IN2 (Pt 100 resistance thermometer).

The 4 to 20 mA control signal is issued at the analog output Y.

Analog inputs

The analog inputs IN1 and IN2 can be adjusted to the following ranges:

- 0 to 20 mA, 4 to 20 mA, 0 to 10 V, 2 to 10 V
- Pt 100, Pt 1000, Ni 100, Ni 1000 resistance thermometers in three-wire circuits:

The resistance of each connection lead must be the same and not exceed 15 Ω. Resistance thermometers can also be connected in two-wire circuits.

i Note

In two-wire circuits, take into account that the lead resistance may reach several ohms over long distances, causing the measured value to be considerably distorted. This measured value can be compensated for by a correction value (see '-CO- F.FOR Feedforward control' in the Configuration Manual ► KH 6493).

- Potentiometer 1 kΩ (resistance transmitter) in three-wire circuit:
A potentiometer is used, for example for position feedback of an electrical actuator or for input of an external set point.
- The controller is configured to assign an input to the controlled variable **X** and the other input to the input variable **WE**. The input variable **WE** can be used as an external set point, feedforward control input value (auxiliary controlled variable) or external position feedback. The '-CO- F.FOR Feedforward control' function allows two input variables to be added or subtracted. For example, a

Design and principle of operation

differential control can be implemented by subtracting two inputs.

Binary input

The binary input BI1 is activated by a voltage signal (4 to 31 V DC) and can be used as follows:

- Start set point ramp
- Switchover between set points
- Increase/decrease actual value
- Activation of the constant output value (e.g. for enabling control)
- Manual/automatic switchover
- Start output ramp
- Locking manipulated variable
- Activate binary outputs
- Lock control keys

➔ ► KH 6493.

Several functions can be assigned to the binary input.

Analog output

The following ranges can be adjusted for the analog output Y:

- 0 to 20 mA, 4 to 20 mA, 0 to 10 V, 2 to 10 V

The manipulated variable Y is issued at the analog output by default. Alternatively, the input variables **X** and **WE** as well as the error **Xd** can be issued.

Binary outputs

The binary outputs BO1 and BO2 are designed as relays with double-throw contacts. They can either be used as a three-step output, on/off output or to monitor limit values and issue status alarms.

The binary output BO3 is designed as a galvanically isolated transistor output to indicate collective error messages. If an internal error exists or the configured signal monitoring of the inputs responds, the externally connected voltage signal (3 to 50 V DC, max. 30 mA) is generated.

Supply output – Transmitter supply

The supply output (20 V DC, max. 45 mA) can be used to supply two two-wire transmitters and the binary input.

Infrared interface

The infrared interface is used to exchange data between the controller and the TROVIS-VIEW software.

Configuration

The compact controller can either be configured and operated directly at the controller using the keys on the front panel (see the 'Operation' section) or on a computer using the TROVIS-VIEW software (► T 6661 and ► EB 6661).

i Note

TROVIS-VIEW provides a uniform user interface that allows users to configure and parameterize various SAMSON devices using device-specific database modules. The device module 6493 can be downloaded free of charge from our website at

▶ www.samsongroup.com > SERVICE & SUPPORT > Downloads > TROVIS-VIEW. Further information on TROVIS-VIEW (e.g. system requirements) is available on our website and in the Data Sheet ▶ T 6661.

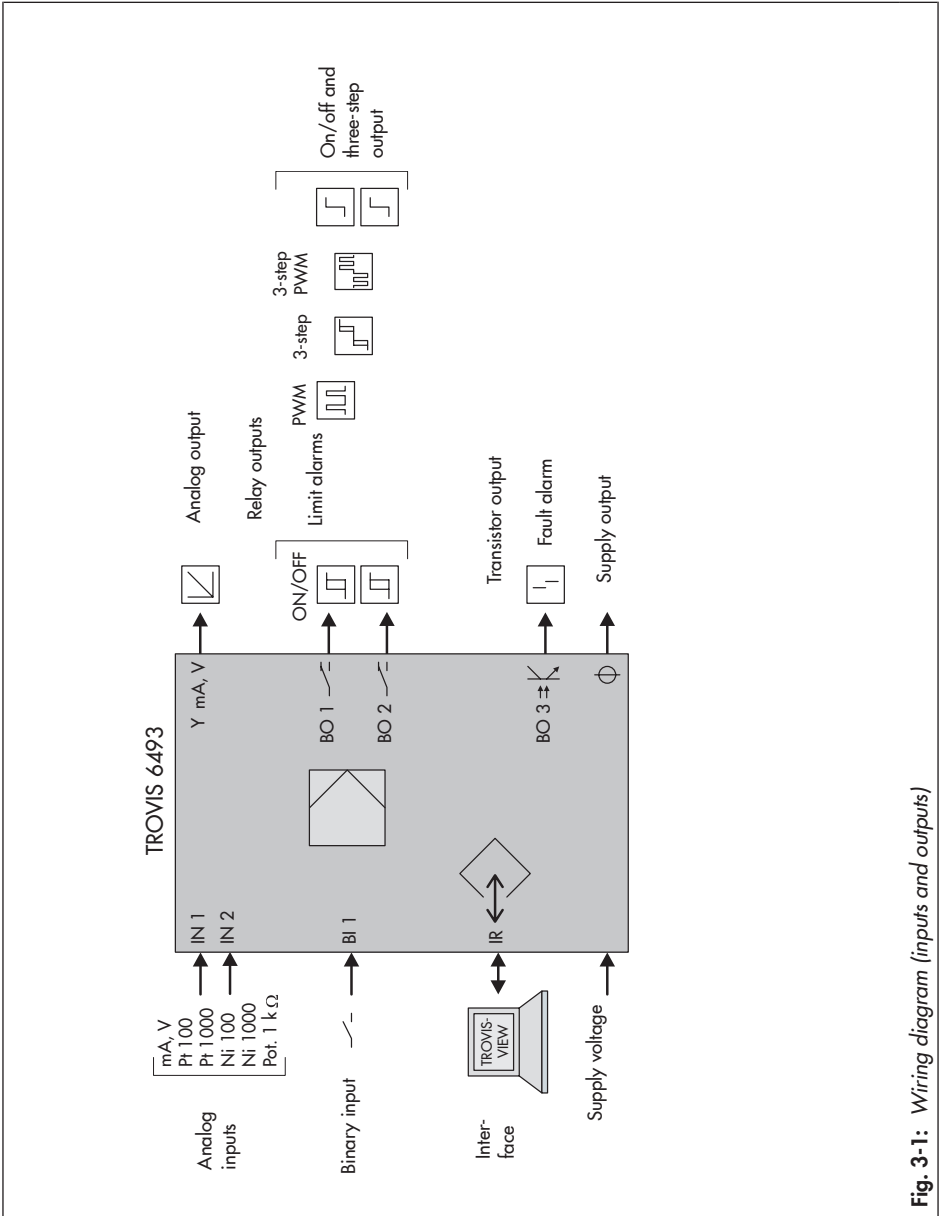

Fig. 3-1: Wiring diagram (inputs and outputs)

3.1 Technical data

Table 3-1: *Technical data · TROVIS 6493*

Inputs		
Analog input IN1 Analog input IN2		Two analog inputs, optionally for controlled variable X or external set point WE 0/4 to 20 mA or 0/2 to 10 V, resistance thermometer Pt 100, Pt 1000, Ni 100, Ni 1000 or potentiometer 1 k Ω
Input for current and voltage	Nominal signal range	0/4 to 20 mA or 0/2 to 10 V
	Max. permissible values	Current ± 50 mA, voltage ± 25 V
	Internal resistance	Current $R_i = 50 \Omega$, voltage $R_i = 20 \text{ k}\Omega$
	Permissible common mode voltage	0 to 5 V
	Error	Zero <0.2 %, span <0.2 %, linearity <0.2 %
	Effect of temperature	<0.1 %/10 K for zero and span ¹⁾
	Resolution	<0.0024 mA <1.2 mV
Transmitter supply		According to DIN IEC 381 (NAMUR Recommendation NE 06) 20 V DC, max. 45 mA, resistant to short circuiting
Resistance thermometer	For sensor	Pt 100, Pt 1000 according to DIN EN 60751 Ni 100, Ni 1000 according to DIN 43760
	Nominal measuring range	Pt 100, Pt 1000: -100 to +500 °C Ni 100, Ni 1000: -60 to +250 °C
	Wire resistance	Three-wire $R_{L1} = R_{L2} = R_{L3} < 15 \Omega$
	Error	Zero < 0.2 %, span < 0.2 %, linearity < 0.2 %
	Pt 100, Pt 1000 in the range between -40 and +150 °C	Zero < 0.1 %, span < 0.1 %, linearity < 0.1 %
	Effect of temperature	<0.2 %/10 K for zero and span ¹⁾
	Resolution	<0.04 °C (<0.007 % at -100 to +500 °C)

¹⁾ Based on 20 °C

Design and principle of operation

Inputs		
Resistance transmitters (potentiometers)	Nominal value	1 k Ω , three-wire
	Wire resistance	$R_L < 15 \Omega$ per wire
	Error	Zero <0.2 %, span <0.2 %
	Effect of temperature	Zero <0.1 %/10 K, span <0.2 %/10 K ¹⁾
	Resolution	<0.07 Ω (<0.007 %)
Binary input	Switching contact – With external supply 24 V DC (4 to 31 V DC) or – Powered by the controller over terminals 14, 15 (20 V DC) Signal state OFF with 0 to 2 V Signal state ON with 4 to 31 V Current draw <6 mA at 24 V DC <5.5 mA at 20 V DC	

¹⁾ Based on 20 °C

Outputs		
Analog output	Nominal signal range	0/4 to 20 mA, load <740 Ω 0/2 to 10 V, load >3 k Ω
	Max. permissible signal range	0 to 22 mA, 0 to 11 V
	Error	<0.2 %
	Effect of temperature	Zero <0.1 %/10 K, span <0.1 %/10 K
	Resolution	<0.0015 mA (<0.0075 % with 0 to 20 mA) <0.0094 % with 4 to 20 mA) <0.75 mV (<0.0075 % with 0 to 10 V)
Binary output BO1 Binary output BO2	Two relays with floating switching contact, max. 250 V AC, max. 250 V DC, max. 1 A AC, max. 0.1 A DC, $\cos \varphi = 1$	
	Spark suppression	Connected in series $C = 2.2$ nF and varistor 300 V AC, in parallel to each relay contact
Binary output BO3 for fault alarms	Isolated transistor output, external supply 3 to 50 V DC, max. 30 mA	
Infrared interface	Transmission protocol: SAMSON protocol (SSP) Transmission rate: 9600 bit/s Angle of reflected beam: 50° Distance between infrared adapter and controller: max. 0.7 m	

General specifications	
Display	Backlit LCD
Display range	-999 to +9999; start value, end value and decimal separator can be adjusted
Configuration	Functions saved in read-only memory for fixed set point and follow-up control, one control circuit
Supply voltage	90 to 250 V AC; 47 to 63 Hz 24 V AC/DC (20 to 30 V AC/DC), 47 to 63 Hz
Power consumption	13 VA (90 to 250 V AC), external fuse >630 mA (slow) 7 VA (24 V AC/DC), external fuse >1.25 A (slow)
Type of connection	Screw clamp terminals
Wire cross-section	Max. 1.5 mm ²
Temperature	Ambient: 0 to 50 °C Storage and transport: -20 to +70 °C
Mechanical environmental conditions affecting storage, transport and operation	Sinusoidal vibration according to IEC 60068-2-6: 2 to 9 Hz; 3.5 mm amplitude 9 to 200 Hz; 10 m/s ² acceleration 200 to 500 Hz; 15 m/s ² acceleration Random and guidance vibration according to IEC 60068-2-64: 1.0 m ² /s ³ ; 10 to 200 Hz 0.3 m ² /s ³ ; 200 to 2000 Hz Shocks according to IEC 60068-2-27: Acceleration 100 m/s ² ; duration 11 ms
Degree of protection	IP 65 (front), IP 30 (housing), IP 00 (terminals) according to EN 60529
Device safety	According to EN 61010-1: Class of protection II Overvoltage category II Degree of contamination 2 Design and testing according to EN 61010-1
Electromagnetic compatibility	Requirements according to EN 61000-6-2, EN 61000-6-3 and EN 61326-1
Cycle time	≤80 ms
Weight	Approx. 0.5 kg
Conformity	

3.2 Dimensions

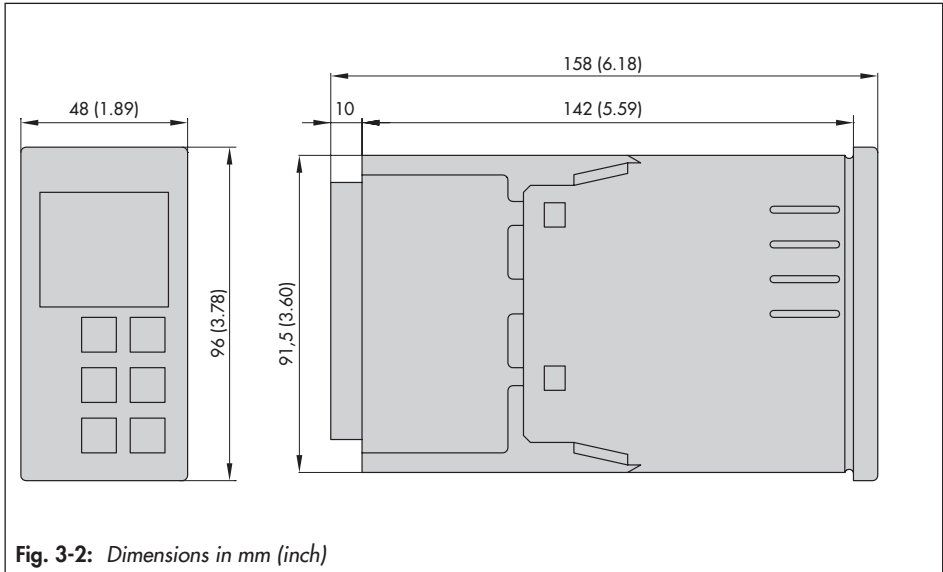

3.3 Values for resistance thermometers

Pt 100 sensors (according to DIN EN 60751:2009-05)

Temperature °C	-100	-90	-80	-70	-60	-50	-40	-30	-20	-10	0
Resistance Ω	60.26	64.30	68.33	72.33	76.33	80.31	84.27	88.22	92.16	95.09	100.00
Temperature °C	+10	+20	+30	+40	+50	+60	+70	+80	+90	+100	+110
Resistance Ω	103.90	107.79	111.67	115.54	119.40	123.24	127.08	130.90	134.71	138.51	142.29
Temperature °C	+120	+130	+140	+150	+160	+170	+180	+190	+200	+210	+220
Resistance Ω	146.07	149.83	153.58	157.33	161.05	164.77	168.48	172.17	175.86	179.53	183.19
Temperature °C	+230	+240	+250	+260	+270	+280	+290	+300	+310	+320	+330
Resistance Ω	156.84	190.47	194.10	197.71	201.31	209.90	208.48	212.05	215.61	219.15	222.68
Temperature °C	+340	+350	+360	+370	+380	+390	+400	+410	+420	+430	+440
Resistance Ω	226.21	229.72	233.21	236.70	240.18	243.64	247.09	250.53	253.96	257.38	260.78
Temperature °C	+450	+460	+470	+480	+490	+500					
Resistance Ω	264.18	267.56	270.93	274.29	277.64	280.98					

Pt 1000 sensors

Multiply the corresponding resistance values in the 'Pt 100 sensors' table by 10.

Ni 100 sensors (according to DIN 43760:1987-09)

Temperature °C	-60	-50	-40	-30	-20	-10	0	+10	+20	+30	+40
Resistance Ω	69.5	74.3	79.1	84.1	89.3	94.6	100.0	105.6	111.2	117.1	123.0
Temperature °C	+50	+60	+70	+80	+90	+100	+110	+120	+130	+140	+150
Resistance Ω	129.1	135.3	141.7	148.3	154.9	161.8	168.8	176.0	183.3	190.9	198.6
Temperature °C	+160	+170	+180	+190	+200	+210	+220	+230	+240	+250	
Resistance Ω	206.6	214.8	223.2	231.8	240.7	249.8	259.2	268.9	278.9	289.2	

Ni 1000 sensors

Multiply the corresponding resistance values in the 'Ni 100 sensors' table by 10.

4 Shipment and on-site transport

The work described in this section is only to be performed by personnel appropriately qualified to carry out such tasks.

4.1 Accepting the delivered goods

After receiving the shipment, proceed as follows:

1. Compare the shipment received with the delivery note.
2. Check the shipment for transportation damage. Report any damage to SAMSON and the forwarding agent (refer to delivery note).

4.2 Removing the packaging from the compact controller

i Note

Do not remove the packaging until immediately before mounting and start-up.

1. Remove the packaging from the compact controller.
2. Check scope of delivery (see Fig. 4-1).
3. Dispose and recycle the packaging in accordance with the local regulations.

- | | |
|----|--|
| 1x | TROVIS 6493 Compact Controller including seal for panel mounting (0430-1495) |
| 1x | Document IP 6493 (Important Product Information) |
| 1x | Accessory 1400-7411, consisting of |
| 2x | Mounting clamp for panel mounting |
| 1x | 10-pole screw terminal |
| 1x | 14-pole screw terminal |
| 1x | Adhesive label kit with units |

Fig. 4-1: Scope of delivery

4.3 Transporting the compact controller

Transport instructions

- Protect the compact controller against external influences (e.g. impact).
- Protect the compact controller against moisture and dirt.
- Observe transport temperature depending on the permissible ambient temperature (see the 'Design and principle of operation' section).

4.4 Storing the compact controller

! NOTICE

Risk of damage to the compact controller due to improper storage.

- ➔ *Observe the storage instructions.*
- ➔ *Avoid long storage times.*
- ➔ *Contact SAMSON in case of different storage conditions.*

i Note

We recommend regularly checking the compact controller and the prevailing storage conditions during long storage periods.

Storage instructions

- Protect the compact controller against external influences (e.g. impact).
- Protect the compact controller against moisture and dirt. In damp spaces, prevent condensation. If necessary, use a drying agent or heating.
- Make sure that the ambient air is free of acids or other corrosive media.
- Observe transport temperature depending on the permissible ambient temperature (see the 'Design and principle of operation' section).
- Do not place any objects on the compact controller.

5 Installation

The work described in this section is only to be performed by personnel appropriately qualified to carry out such tasks.

5.1 Installation conditions

Work position

The work position for the compact controller is the front view onto the operating controls on the compact controller seen from the position of operating personnel.

Operators must ensure that, after installation of the compact controller, the operating personnel can perform all necessary work safely and easily access the device from the work position.

5.2 Preparation for installation

Before installation, make sure the following conditions are met:

- The compact controller is not damaged.

Proceed as follows:

- ➔ Lay out the necessary material and tools to have them ready during installation work.

5.3 Mounting the compact controller

The TROVIS 6493 Controller is designed for panel mounting.

➔ See Fig. 5-1.

1. Make a panel cut-out with the dimensions $45^{+0.6} \times 92^{+0.8}$ mm.
2. Place the supplied seal onto the compact controller. Push the compact controller into the panel cut-out from the front.
3. Insert the supplied mounting clamps (1) into the top and bottom recesses.
4. Turn threaded rods towards the panel using a screwdriver, clamping the housing against the panel.

! NOTICE

The IP rating will be lower if the controller is not fastened properly.

➔ *Tighten the threaded rods far enough to ensure the specified IP rating is achieved.*

Installation

Dimensions in mm (inch)

Panel cut-out: $45^{+0.6} \times 92^{+0.8}$

Mounted depth including terminals (without wiring): 151 (5.95)

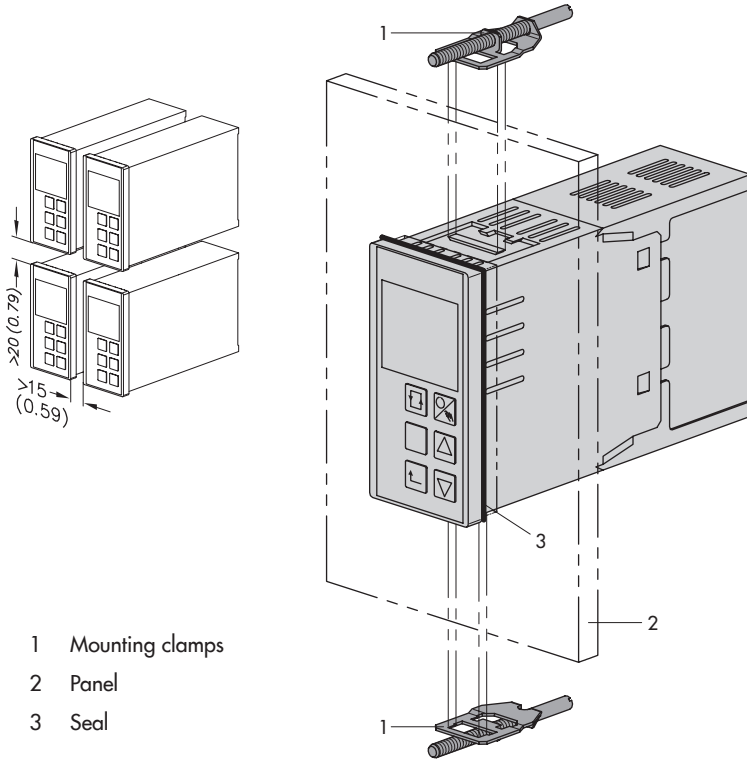

Fig. 5-1: Installation

5.4 Electrical connection

⚠ DANGER

Risk of fatal injury due to electric shock.

- For electrical installation, you are required to observe the relevant electro-technical regulations of the country of use as well as the regulations of the local power suppliers.

Therefore, such work must be performed by trained and experienced personnel.

- Do not connect ELV cables (according to VDE 0100) to these terminals.
- Before performing any work on the terminals, disconnect the voltage supply from the compact controller.

Notes on electric wiring

- Install the power supply lines and the signal lines separately. Do not install them parallel to each other.
- To improve noise immunity, observe a minimum distance of 10 cm between the power line and the measuring input line.
- To avoid measurement errors or other disturbances, use shielded cables for the analog and binary signal lines. Ground the shield at one side, either at the control cabinet inlet or outlet, using the largest possible cross-section.
- Connect the central grounding point and the PE grounding conductor with a cable with 10 mm² wire cross-section using the shortest route.

- Inductances in the control cabinet, e.g. contactor coils, must be equipped with suitable interference suppressors (RC elements).
- Control cabinet elements with high field strength, e.g. transformers or frequency converters, must be shielded with separators providing a good ground connection.

The compact controller has plug-on screw terminals for lines with a wire cross-section from 0.5 to 1.5 mm². The lines are connected to the terminal strips 1 to 2 (see Fig. 5-2).

- Plug the plug-on screw terminals securely into the appropriate connector sockets in the controller.

Note on analog inputs

- When resistance thermometers are connected in two-wire circuits, connect a jumper to the controller terminals (see Fig. 5-2).

i Note

The lead resistance can reach several ohms over long distances, causing the measured value to be considerably distorted. This can be compensated for by a correction value (see '-CO- F.FOR Feedforward control' in the Configuration Manual ► KH 6493).

i Note

Generally for potentiometers, we recommend performing a zero and span calibration (see '-CO- ADJ Calibration of analog inputs and analog output' in the 'Operation' section).

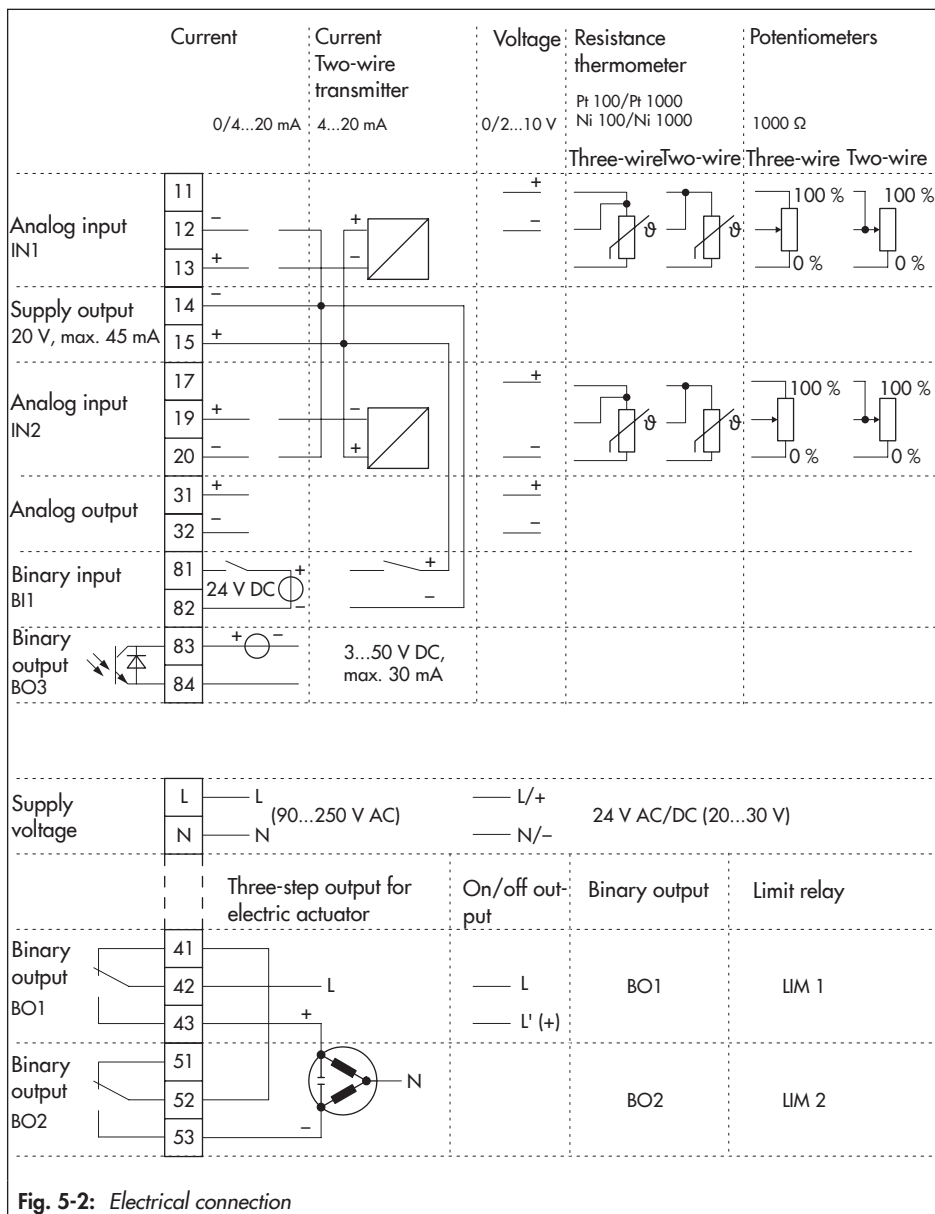

Fig. 5-2: Electrical connection

6 Operation

6.1 Device overview

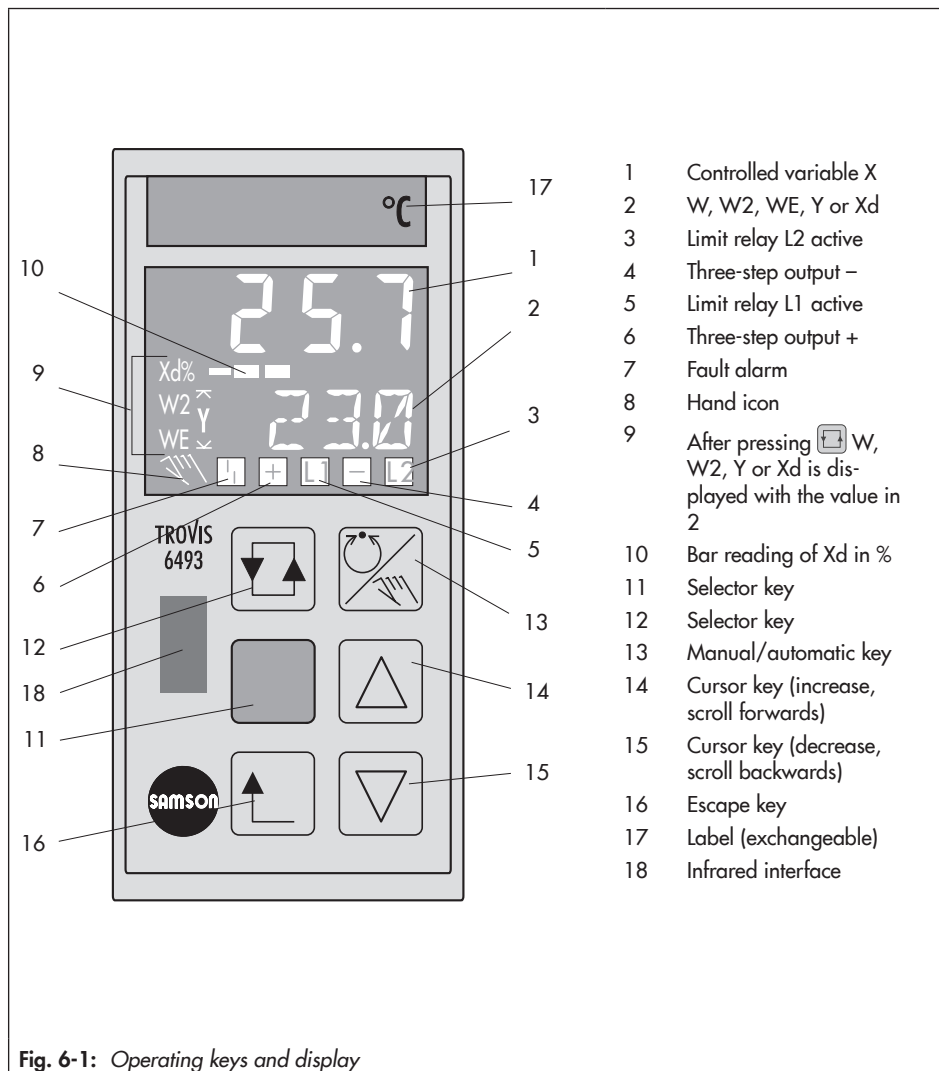









Fig. 6-1: Operating keys and display

6.2 Operating controls



The compact controller is operated using the operating keys on the front.

Operating keys

The function of the keys varies depending on the level/menu which is active.

Key	Operating level	Configuration level
 Selector key (yellow)	<ul style="list-style-type: none"> – Open configuration level. – Activate set point. ¹⁾ <p>¹⁾ Only when the set point name (W, W2 or WE) blinks on the display</p>	<ul style="list-style-type: none"> – Open menus, functions and parameters. – Confirm settings.
 Selector key	<ul style="list-style-type: none"> – Switch between readings: W Internal set point 1, W2 ¹⁾ Internal set point 2 WE ¹⁾ External set point, Y Manipulated variable, Xd% Error <p>¹⁾ Only when they have been configured (see the 'Start-up and configuration on the device' section).</p>	<ul style="list-style-type: none"> – Open parameter level. – Jump within the value range of an open parameter. – Shift the decimal point one place to the right.
 Manual/automatic key	<ul style="list-style-type: none"> – Switch between manual and automatic mode. ¹⁾ <p>¹⁾ In manual mode, the  icon appears in the display.</p>	No function
 Cursor keys	<ul style="list-style-type: none"> – Change the value of internal set point. ¹⁾ – Change the control output. ²⁾ <p>¹⁾ Only when selected using the selector key. ²⁾ Only when Y has been selected using the selector key or when manual mode () has been selected.</p>	<ul style="list-style-type: none"> – Select menus, functions and parameters. – Set parameters and functions.
 Escape key	<ul style="list-style-type: none"> – Display current set point. 	<ul style="list-style-type: none"> – Return to the operating level stepwise.
No keys pressed	The display changes back to the currently valid set point. Exceptions: In manual mode and when the manipulated variable is displayed	The controller returns to the operating level after approximately five minutes.

6.3 Display

No.	Operating level	Configuration level
	Depending on the level selected, the following variables and operating states are shown on the display	
1	Controlled variable X	Designations, settings and values of functions and parameters (see the 'Design and principle of operation' section)
2	Value of W , W2 , WE , Y or Xd	
3	Limit relay L2 active	No reading
4	Three-step output -	No reading
5	Limit relay L1 active	No reading
6	Three-step output + or on/off output	No reading
7	Fault alarms (▶ KH 6493 and the 'Malfunctions' section)	No reading
8	Hand icon displayed in manual mode, no icon in automatic mode	No reading
9	Press  key to display W , W2 , WE , Y or Xd % in sequence. The associated value appears in (2). W2 and WE only when they have been configured (▶ KH 6493).	Fast access to parameters: Each time the  key is pressed, the decimal point of the parameter is shifted one place to the right.
10	Bar reading of Xd in %	

6.4 Infrared interface

The infrared interface allows the controller to be configured and operated using the TROVIS-VIEW software. It can be accessed from the front of the controller. It is located above the SAMSON logo (see Fig. 6-1).

i Note

Further information on configuration and operation using the TROVIS-VIEW software is available in ► EB 6661.

An infrared interface is required for data transmission between the serial RS-232 port of the computer and the infrared interface on the controller.

A bracket ensures that the adapter is properly aligned in front of the controller. The infra-red adapter can be connected to the USB port of the computer using the USB to RS-232 adapter. A driver must be installed to use the adapter (see Annex B).

→ Proceed as described in the 'Start-up and configuration with TROVIS-VIEW' section.

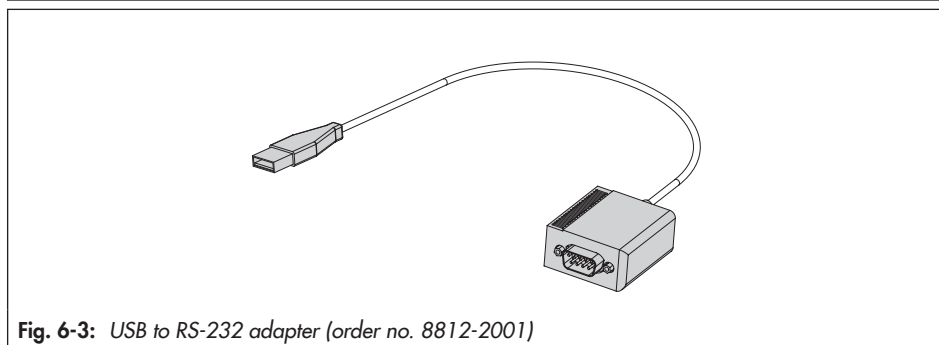
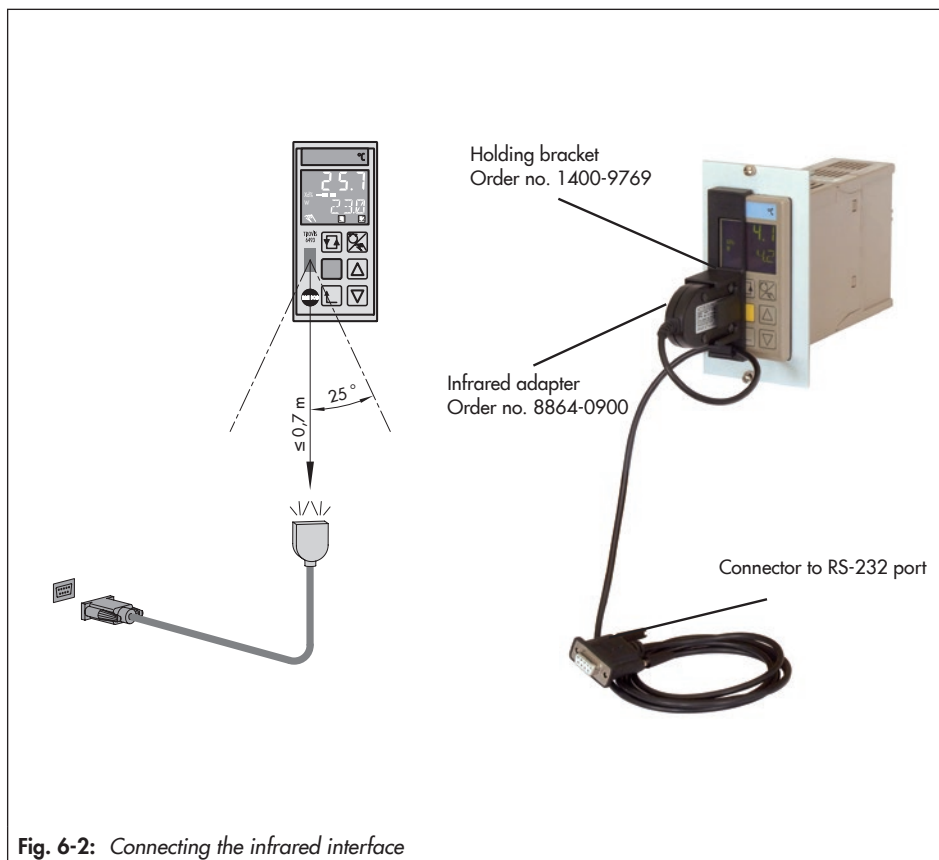

7 Start-up and configuration at the device

The work described in this section is only to be performed by personnel appropriately qualified to carry out such tasks.

Before start-up, make sure the following conditions are met:

- The compact controller is properly mounted according to the instructions.
- The electrical connection is properly performed.

After applying the supply voltage, the compact controller is ready for use.

➔ When potentiometers are used, perform a zero and span calibration (see '-CO- ADJ Calibration of analog inputs and analog output' in the 'Operation' section).

7.1 Configuration

The controller is configured in the configuration level. In the configuration menu, the controller is adapted to its control task by changing individual configuration items and parameters. Annex A contains an overview of all possible settings that can be made. The Configuration Manual ► KH 6493 contains detailed descriptions on individual configuration items as well as other helpful information.

You can enter the configuration data into the configuration protocol (see Annex A).

Configuration level

You can configure functions and parameters of the compact controller to adapt to a specific control task. The configuration level has nine menus assigned to functions and their parameters: Each one of the nine menus contains the functions for a certain topic:

- PAR: Control parameters
- IN: Input
- SETP: Set point
- CNTR: Controller
- OUT: Output
- ALRM: Limit relays
- AUX: Additional functions
- TUNE: Start-up adaptation
- I-O: Process data

Start-up and configuration at the device

Operation in the configuration level

→ See Annex A (configuration guide).

The settings of the controller in the configuration level are shown in the form of schematic diagrams:

- ① Open configuration level
 - ② Enter menu
 - ③ Select function/parameter
 - ④ Show setting
 - ⑤ Activate editing mode for setting/value
 - ⑥ Change setting/value
 - ⑦ Confirm setting/value
 - ⑧ Open parameter level
- ¹⁾ After opening the configuration level, you are prompted to enter the key number before you edit the first function/parameter. If you want to work without a key number, press the enter key again to continue with the editing mode. Editing is enabled until you exit the configuration level.

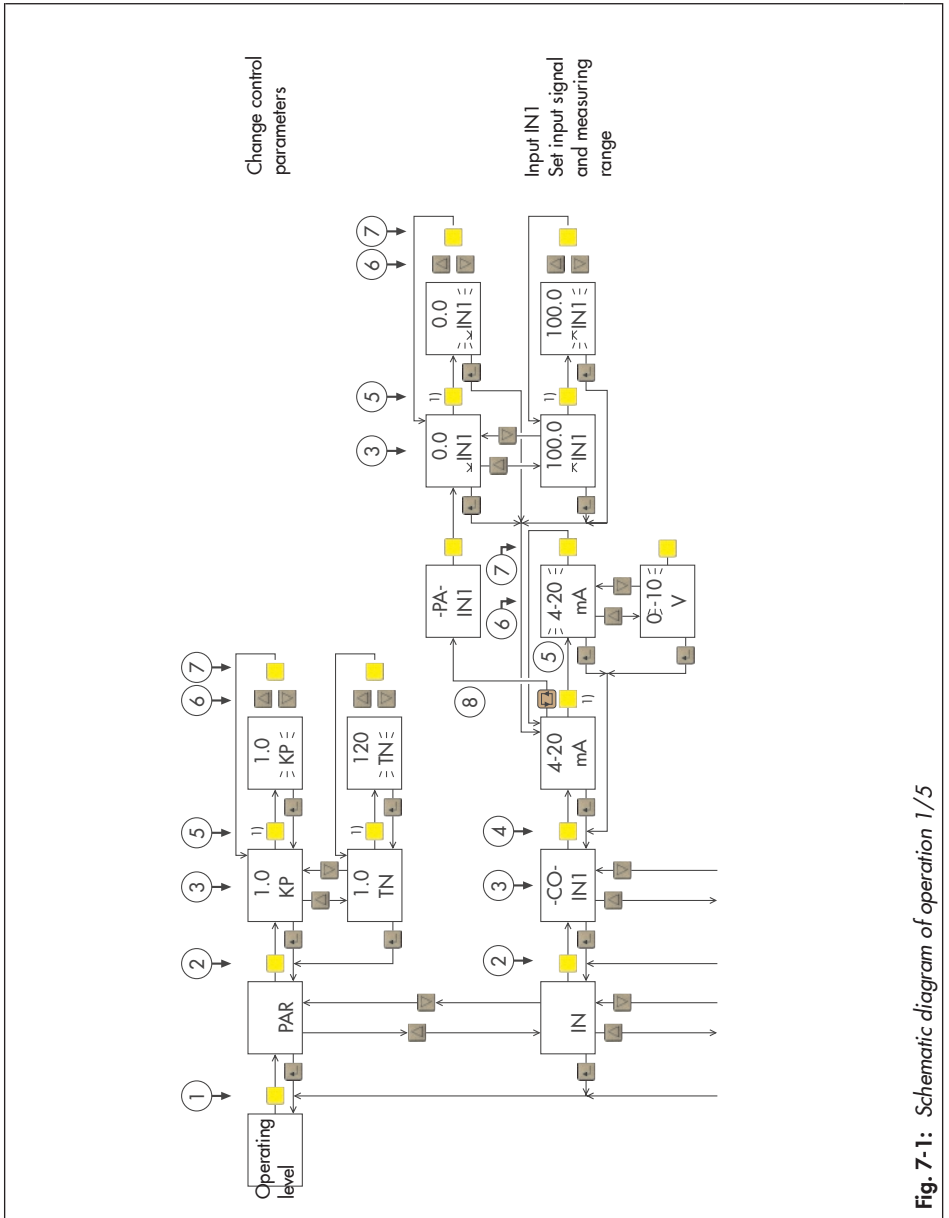

Fig. 7-1: Schematic diagram of operation 1/5

Start-up and configuration at the device

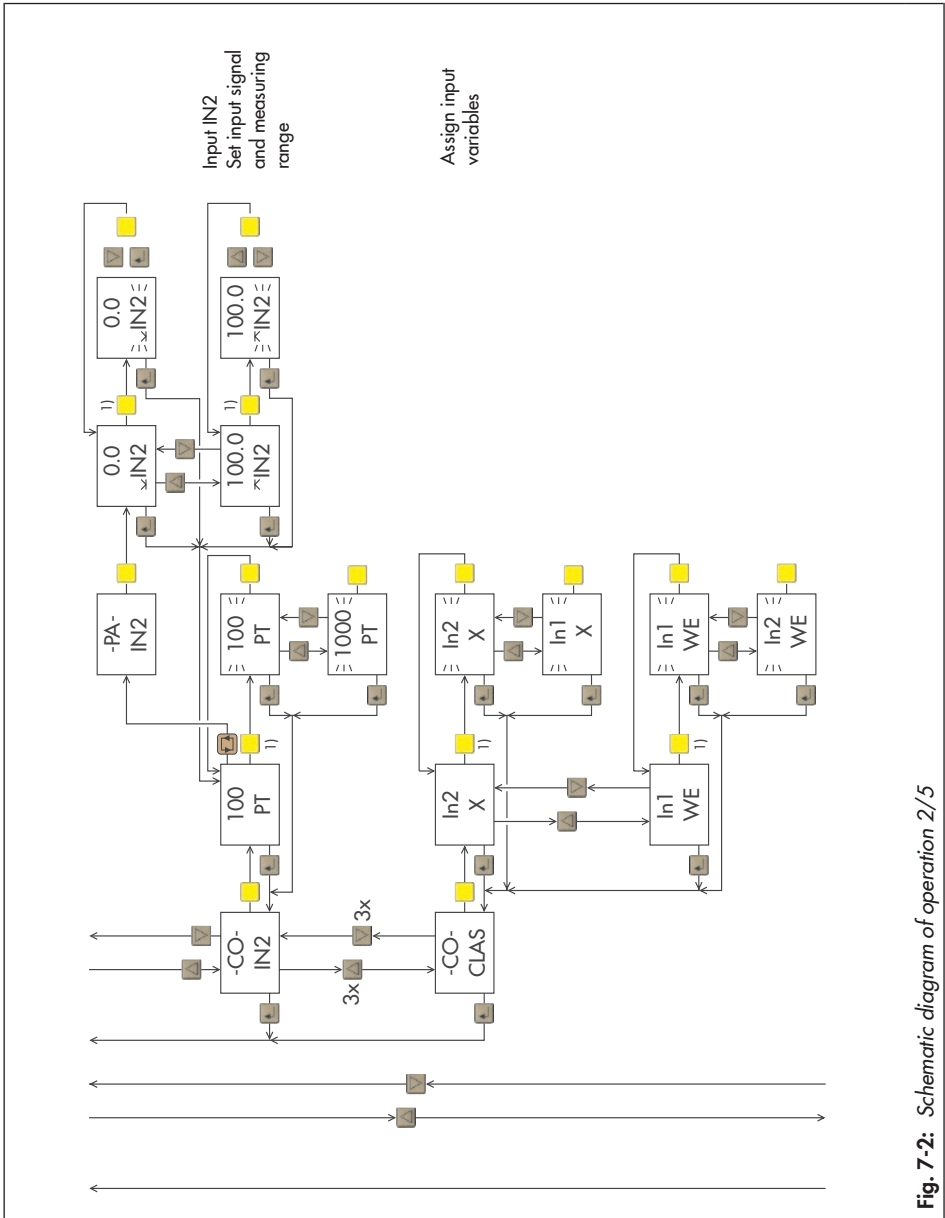

Fig. 7-2: Schematic diagram of operation 2/5

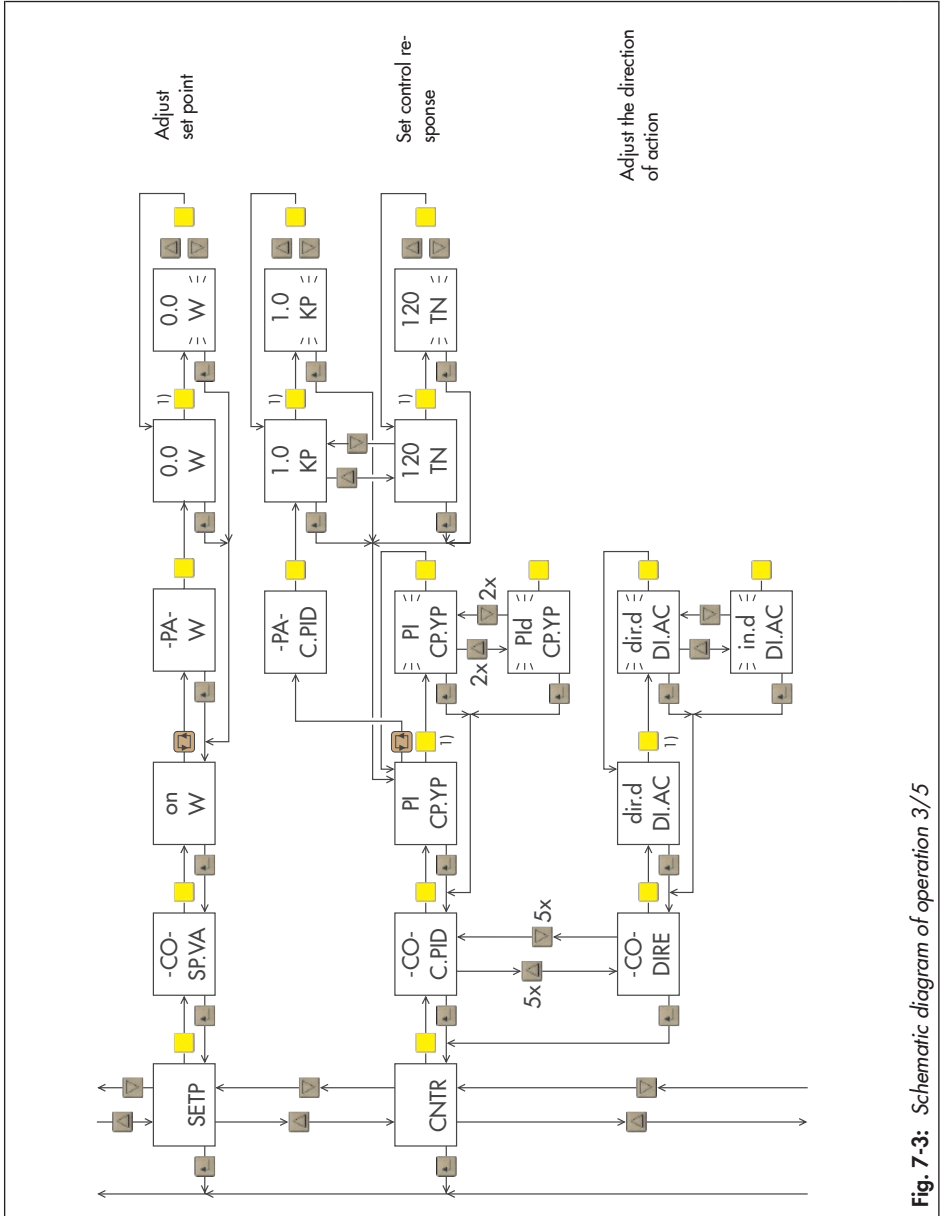

Fig. 7-3: Schematic diagram of operation 3/5

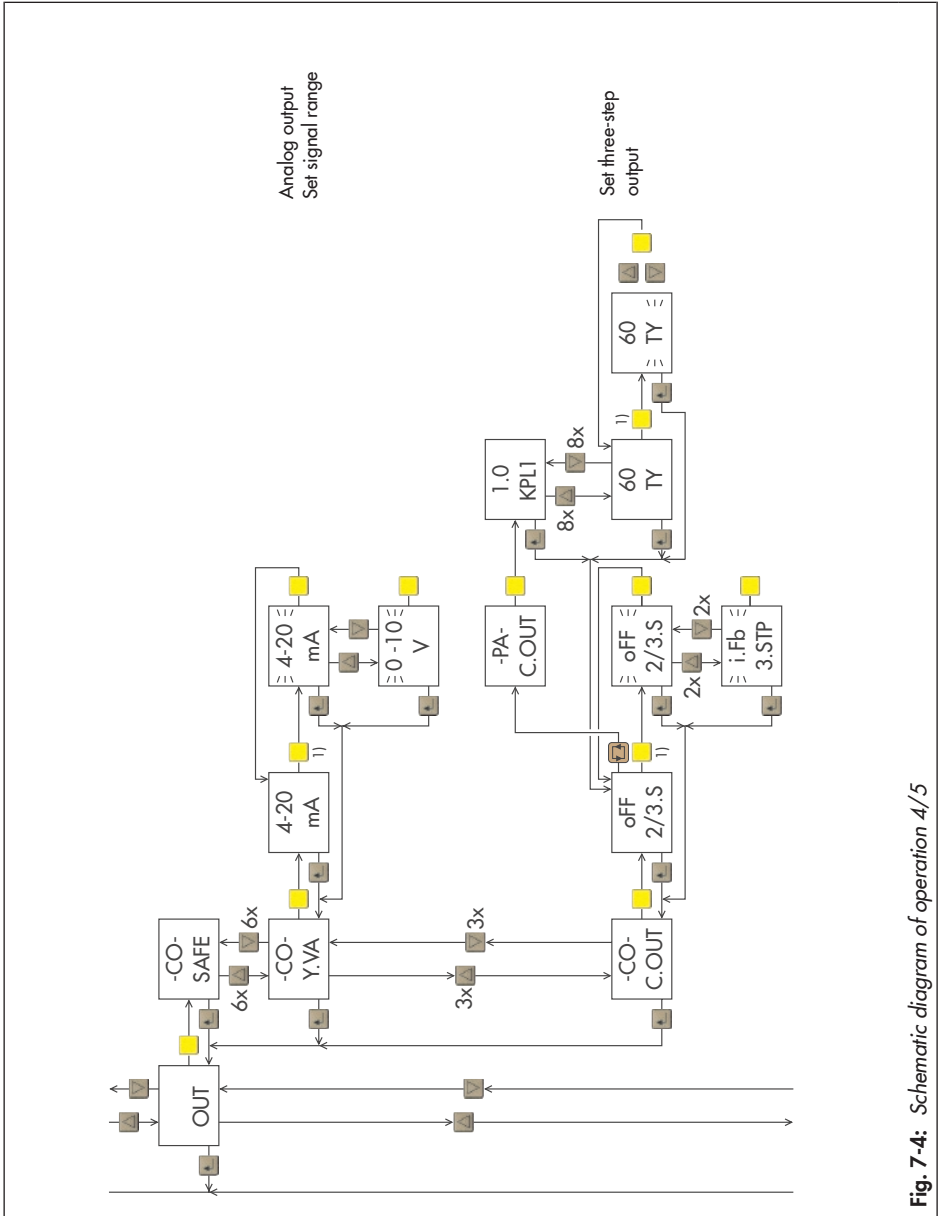

Fig. 7-4: Schematic diagram of operation 4/5

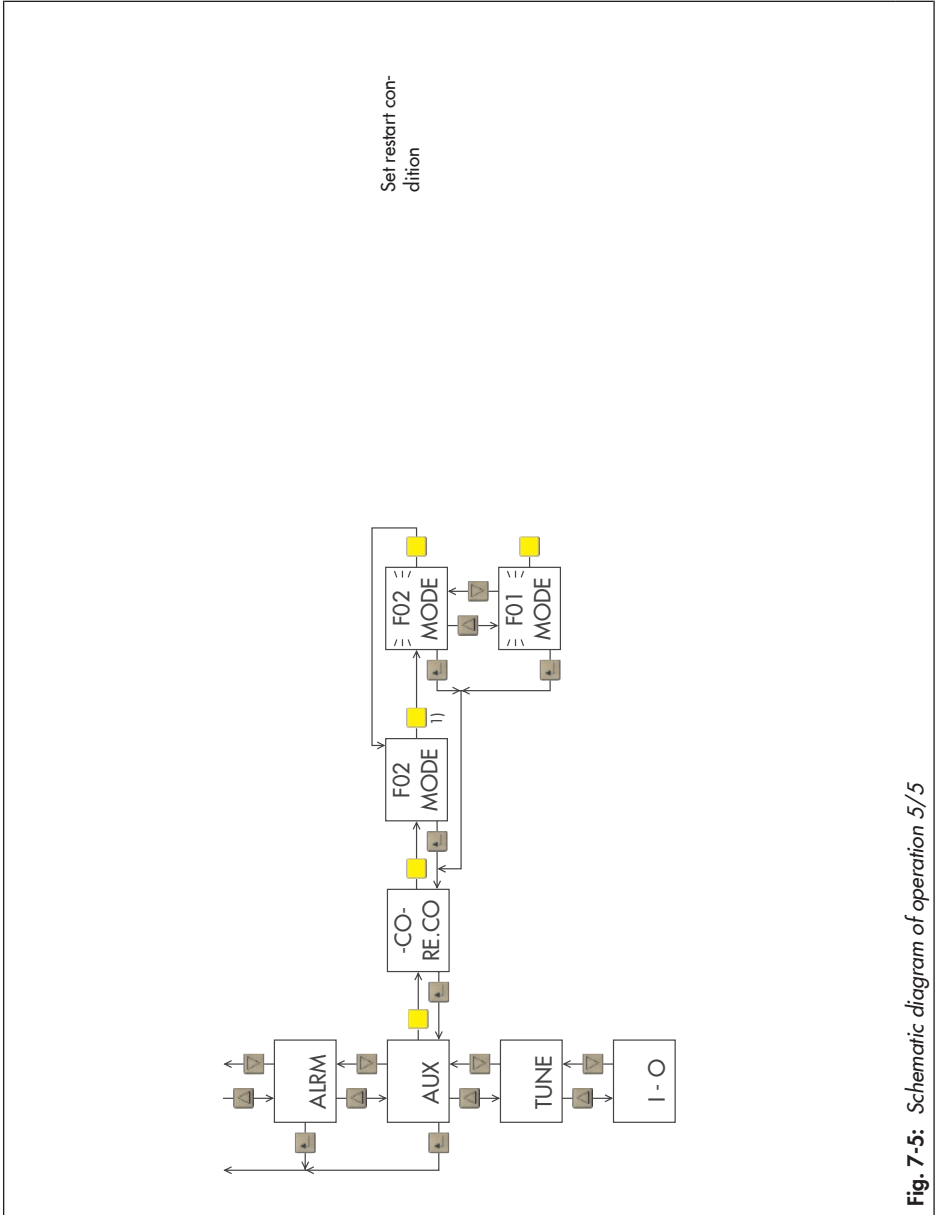

Fig. 7-5: Schematic diagram of operation 5/5

7.1.1 Configuring the compact controller

To set a function or parameter, you need to know the abbreviated code used for the function/parameter and the menu where it can be found (see example in "Configuration and parameterization example" on page 7-9, Annex A).

How to proceed:

The controller is in the operating level.

- Open configuration level.

Reading: PAR (Control parameters menu)

If the function you want to configure is located in a different menu:

- Select the required menu: IN, SETP, CNTR, OUT, ALRM, AUX, TUNE or I-O

- Enter menu.

Reading: -CO- and abbreviated code of the first function in the current menu

If you want to configure a different function:

- Select the function you want to configure.

- Open function.

Reading: current function setting

- Activate editing mode for the function.

Current function setting blinks.

i Note

*Every time you go to the first function or parameter after opening the configuration level, you are prompted to enter the key number (reading: - - - - and **KEY**). The key number only needs to be entered if a key number has already been assigned to the controller (see the 'Operation' section). If this is not the case, entry of the key number can be skipped by pressing the enter key ()*

- Select the setting.

- Confirm setting.

- Change to the parameter level.

Reading: -PA-

→ Open parameter level.

Reading: code of the first parameter

If you want to configure a different parameter:

 → Select parameter.

→ Activate editing mode for the parameter.

The code of the function parameter blinks.

 → Set the parameter.

→ Confirm setting.

After setting all parameters:

 → Press until the controller is back in the operating level.

i Note

The controller automatically returns to the operating level five minutes after the last key has been pressed.

Configuration and parameterization example

The compact controller is to be configured to be a PID controller. The associated proportional-action coefficient (KP) is to be set to 1.5. Refer to the overview in Annex A. This overview shows that time behavior is defined by the C.PID function in the CNTR menu.

Menu	Function -CO-	Setting options ¹⁾	Description of functions	Parameters -PA-
Control structure and functions				
CNTR	C.PID Control algorithm	P CP.YP	P behavior	C.PID/CP.YP
		PI CP.YP	PI behavior	C.PID/CP.YP
		Pd CP.YP	PD behavior	C.PID/CP.YP
		PId CP.YP	PID behavior	C.PID/CP.YP
		PPI CP.YP	P ² I behavior	C.PID/CP.YP

The proportional-action coefficient is set with the **KP** parameter.

Start-up and configuration at the device

Parameter selection	Parameter name	Value range ¹⁾	See
	Proportional-action coefficient	[0.1 ... 1.0 ... 100.0]	► KH 6493
	Reset time	[1 ... 120 ... 9999 s]	
	Derivative-action time	[1 ... 10 ... 9999 s]	
	Derivative-action gain	[0.10 ... 1.00 ... 10.00]	
	Operating point	[-10.0 ... 0.0 ... +110.0]	
	Dead band error Xd	[0.0 ... 110.0 %]	
↘ DZXD	Minimum effective error Xd	[- 110.0 % ... ↗ DZXD]	
↗ DZXD	Maximum effective error Xd	[↘ DZXD ... 110.0 %]	

¹⁾ Default setting is in **bold print**.

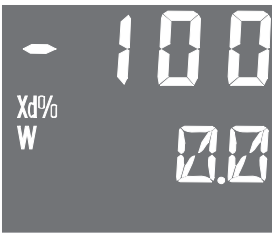

The controller is in the operating level.
The reading on the display looks like this.



→ Open configuration level.
Reading: **PAR** (Control parameters menu)



→ 3 x
Select CNTR (Controller) menu.

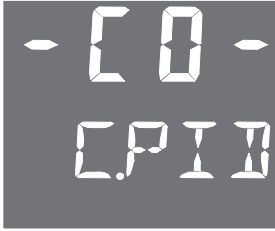

- Enter menu.

Reading: **-CO-** and **C.PID** (first function of CNTR menu)



- Open function.

Reading: **PI** (current setting of **C.PID** function)

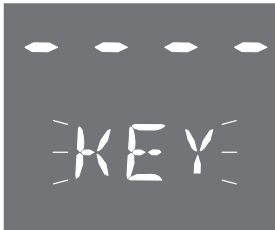

- Activate editing mode for the function.

Reading: Prompt for key number



- Only for operation with key number:

- Enter valid key number (27 in this example).



- Exit prompt for key number.

The **CP.YP** function is in the editing mode. **PI** blinks.

Start-up and configuration at the device



-
- 2x
Change PI to PID control algorithm.



-
- Confirm setting.
The editing mode is exited.

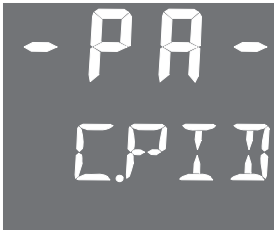

-
- Change to the parameter level.
Reading: **-PA-** and **C.PID/CP.YP** blink in alternating sequence



-
- Open parameter level.
Reading: **KP** (first parameter of **C.PID** function)
-



- Activate editing mode for the parameter.
KP blinks.



- Set proportional-action coefficient **KP** to 1.5.



- Confirm setting.
The editing mode is exited.



i Note

If you want to change other parameters in the function, select the parameters () and repeat the steps (gray background).

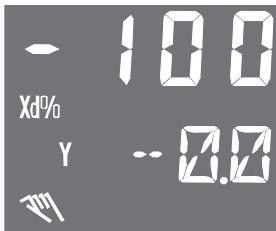

- 4x
Return to the operating level.

7.2 Entering the key number

The TROVIS 6493 Compact Controller can be operated with or without a key number. The controller is set to operate without key number by default. Operation with a key number is only activated after a user-defined key number has been assigned. The service key number is required to define a user-defined key number.

i Note

The overriding service key number is specified in the printed document IMPORTANT PRODUCT INFORMATION IP 6493, which is supplied with the device. This number allows configuration settings and parameters to be changed regardless of user key number operation. To avoid unauthorized use of the service key number, we recommend removing the pages (German and English) containing the service key number from the document IMPORTANT PRODUCT INFORMATION IP 6493 and to keep them in a safe place.

Prompt for key number

Every time you go to the first function or parameter after opening the configuration level, you are prompted to enter the key number:

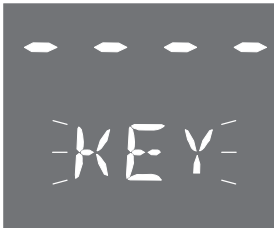

KEY blinks.

i Note



When this reading appears, you can change the user-defined key number (see 'Activate/deactivate operation with key number').

Operation without key number

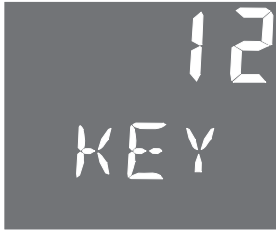
→ Exit prompt for key number.



Operation with key number

-  → Enter valid key number.
-  → Enter valid key number.
- Exit prompt for key number.

i Note

If you enter an incorrect key number, you are prompted again to enter the key number. In this case, 1 appears on the display instead of - - - .

Activate/deactivate operation with key number

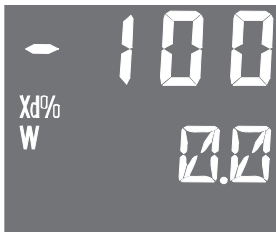

The controller is in the operating level.
The reading on the display looks like this.



-
- Open configuration level.



-
- Open parameter level.
-

Start-up and configuration at the device

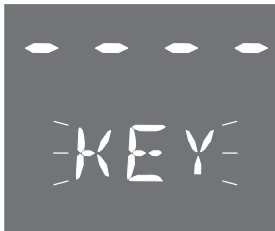

-
- Activate prompt for key number.
KEY blinks.



-
- Enter service key number.

i Note

The overriding service key number is specified in the printed document *IMPORTANT PRODUCT INFORMATION IP 6493*, which is supplied with the device. This number allows configuration settings and parameters to be changed regardless of user key number operation. To avoid unauthorized use of the service key number, we recommend removing the pages (German and English) containing the service key number from the document *IMPORTANT PRODUCT INFORMATION IP 6493* and to keep them in a safe place.

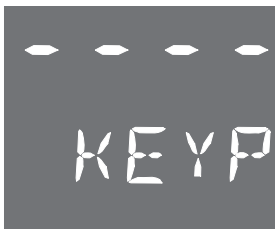

-
- Confirm service key number.
Reading: - - - - and **KEYP**

i Note

A number instead of - - - - means that a key number is already active. The reading shown is the valid key number.

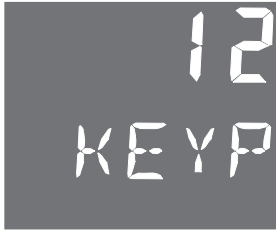

→ Enter your own key number (12 in this example).

→ To deactivate operation with key number, select - - - on the display.



→ Exit prompt for key number.

The controller returns to the configuration level.

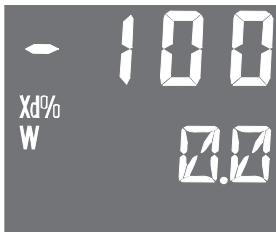

→ Press until the controller is back in the operating level.









7.3 Tuning the control parameters

The controller must be adapted to the dynamic behavior of the controlled system over the parameters **KP**, **TN** and **TV** to ensure that errors caused by disturbances can be eliminated or largely suppressed. It is possible to tune these parameters either by performing the function **-CO- TUNE Start-up adaptation** (see section 7.3.3) or by manual tuning.







7.3.1 Empirical tuning method

The following empirical method can be used to tune control parameters. This method is merely intended as a guide and not a one-size-fits-all solution.

Proceed as follows for a PI controller

1. Switch to manual mode (.
2. In the CNTR menu, set the function **-CO- C.PID** = PI CP.YP.
3. In the PAR menu, set the parameters **KP** = 0.1 and **TN** = 9999 s.
4. In the operating level, set the set point **W** to the required value.
→ Press  to select **W** and use the cursor keys (, ) to set the value.
5. In the operating level, change the manipulated variable **Y** so that the controlled variable **X** has the same value as the set point **W** (error $X_d = 0$).
→ Press  to select **Y** and use the cursor keys (, ) to set the value.
6. Switch to automatic mode (.
7. In the PAR menu, step up the **KP** parameter until the controlled system shows a tendency to oscillate.
Every time the **KP** increases, let the controlled system oscillate, e.g. by making small changes to the set point.
8. In the PAR menu, reduce the **KP** parameter again until the controlled system stops oscillating.
9. In the PAR menu, step up the **TN** parameter until the controlled system shows a tendency to oscillate. Every time the **TN** increases, let the controlled system oscillate, e.g. by making small changes to the set point.
10. In the PAR menu, reduce the **TN** parameter again until the controlled system stops oscillating.
11. Change the set point slightly and check the transient behavior. If necessary, retune **KP** and **TN** until the closed loop shows a satisfactory control behavior.

Proceed as follows for a P controller

1. Switch to manual mode (.
2. In the CNTR menu, set the function **-CO- C.PID** = P CP:YP.
3. In the PAR menu, set the parameter **KP** = 0.1.
4. In the operating level, set the set point **W** to the required value.
 - ➔ Press  to select **W** and use the cursor keys (, ) to set the value.
5. In the operating level, change the manipulated variable **Y** so that the controlled variable **X** has the same value as the set point **W** (error $X_d = 0$).
 - ➔ Press  to select **Y** and use the cursor keys (, ) to set the value.
The output **Y** reading is the operating point of the manipulated variable.
6. In the PAR menu, set the **Y.PRE** parameter to the previously determined operating point of the manipulated variable **Y**.

i Note

For a P controller, every time the set point is changed, the change of the operating point is also necessary if no steady-state error is to exist.

7. Switch to automatic mode (.
8. In the PAR menu, step up the **KP** parameter until the controlled system shows a tendency to oscillate. Every time the **KP** increases, let the controlled system oscillate, e.g. by making small changes to the set point.
9. In the PAR menu, reduce the **KP** parameter again until the controlled system stops oscillating.

7.3.2 Tuning according to the Ziegler and Nichols method

Various tuning methods, such as the Ziegler and Nichols method, are described in control engineering literature. This tuning method can only be applied to controlled systems in which the controlled variable can be made to hunt. For the frequency response test, the controller must run with P action in closed-loop operation.

Start-up and configuration at the device

Proceed as follows for a PI controller

1. Switch to manual mode (☒).
2. In the CNTR menu, set the function **-CO- C.PID** = PI CPYP.
3. In the PAR menu, set the parameters **KP** = 0.1 and **TN** = 9999 s.
4. In the operating level, set the set point **W** to the required value.
 → Press (☐) to select **W** and use the cursor keys (⬆, ⬇) to set the value.
5. In the operating level, change the manipulated variable **Y** so that the controlled variable **X** has the same value as the set point **W** (error $X_d = 0$).
 → Press (☐) to select **Y** and use the cursor keys (⬆, ⬇) to set the value.
6. Switch to automatic mode (☒).
7. In the PAR menu, step up the **KP** parameter until the controlled variable shows an harmonic oscillation pattern.
 Every time the **KP** increases, let the controlled system oscillate, e.g. by making small changes to the set point.
8. Write down the adjusted **KP** value as the critical proportional-action coefficient $K_{p,crit}$.
9. Time how long it takes for one entire oscillation to find T_{crit} .
 To achieve a more precise result, time several oscillations and calculate the average time from the results.

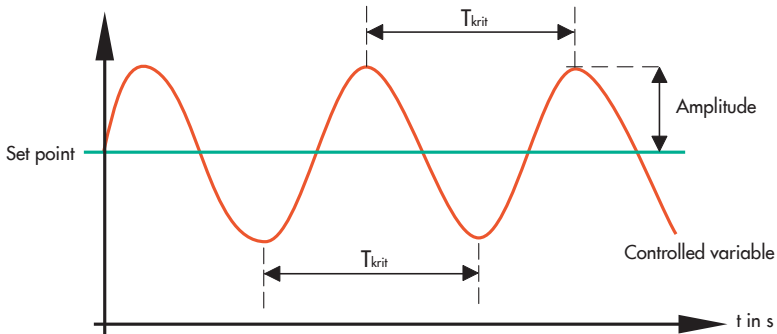

10. Multiply $K_{p,crit}$ and T_{crit} by the factors listed in the table below. Use the results for **KP** and **TN** accordingly.

	KP	TN	TV
PI controller	$0.45 \times K_{p,crit}$	$0.85 \times T_{crit}$	–

- Change the set point slightly and check the transient behavior. If necessary, retune **KP** and **TN** until the closed loop shows a satisfactory control behavior.

Proceed as follows for a P controller

- Switch to manual mode (☒).
- In the CNTR menu, set the function **-CO- C.PID** = P CP:YP.
- In the PAR menu, set the parameter **KP** = 0.1.
- In the operating level, set the set point **W** to the required value.
 → Press (F) to select **W** and use the cursor keys (Δ, ▽) to set the value.
- In the operating level, change the manipulated variable **Y** so that the controlled variable **X** has the same value as the set point **W** (error $X_d = 0$).
 → Press (F) to select **Y** and use the cursor keys (Δ, ▽) to set the value.
 The output **Y** reading is the operating point of the manipulated variable.
- In the PAR menu, set the **Y.PRE** parameter to the previously determined operating point of the manipulated variable **Y**.

i Note

For a P controller, every time the set point is changed, the change of the operating point is also necessary if no steady-state error is to exist.









- Switch to automatic mode (☒).
- In the PAR menu, step up the **KP** parameter until the controlled variable shows a harmonic oscillation pattern.
 Every time the **KP** increases, let the controlled system oscillate, e.g. by making small changes to the set point.
- Write down the adjusted KP value as the critical proportional-action coefficient $K_{p,crit}$.
- Multiply $K_{p,crit}$ by the factor 0.5 and use the result to set **KP** at the controller ($KP = 0.5 \times K_{p,crit}$).

	KP	TN	TV
P controller	$0.5 \times K_{p,crit}$	–	–

- Change the set point slightly and check the transient behavior. If necessary, retune **KP** until the closed loop shows a satisfactory control behavior.

Start-up and configuration at the device

Proceed as follows for a PID controller

1. Switch to manual mode (.
2. In the CNTR menu, set the function **-CO- C.PID** = PI CPYP
3. In the PAR menu, set the parameters **KP** = 0.1 and **TN** = 9999 s.
4. In the operating level, set the set point **W** to the required value.
→ Press  to select **W** and use the cursor keys (, ) to set the value.
5. In the operating level, change the manipulated variable **Y** so that the controlled variable **X** has the same value as the set point **W** (error $X_d = 0$).
→ Press  to select **Y** and use the cursor keys (, ) to set the value.
6. Switch to automatic mode (.
7. In the PAR menu, step up the **KP** parameter until the controlled variable shows an harmonic oscillation pattern.
Every time the **KP** increases, let the controlled system oscillate, e.g. by making small changes to the set point.
8. Write down the adjusted KP value as the critical proportional-action coefficient $K_{p,crit}$.
9. Time how long it takes for one entire oscillation to find T_{crit} .
To achieve a more precise result, time several oscillations and calculate the average time from the results.
10. Multiply $K_{p,crit}$ and T_{crit} by the factors listed in the table below. Use the results for **KP**, **TN** and **TV** accordingly.

	KP	TN	TV
PI controller	$0.59 \times K_{p,crit}$	$0.50 \times T_{crit}$	$0.12 \times T_{crit}$

11. Change the set point slightly and check the transient behavior. If necessary, retune **KP**, **TN** and **TV** until the closed loop shows a satisfactory control behavior.

7.3.3 -CO- TUNE: Start-up adaptation

The purpose of the adaptation is to quickly determine the best settings for the control parameters **KP**, **TN** and **TV** with minimum knowledge of the process to be controlled.

The control parameters are calculated by the controller from the step response according to the rules introduced by Chien, Hrones and Reswick for the aperiodic control operation and a good reference action.

Observe the following:

- The adaptation can only be used for controlled systems with self-regulation.
- The controlled variable must be as constant as possible at the beginning of the adaptation.
- The disturbance variables must not be changed during the adaptation.

First set the manipulated variable **Y** to a start value. In a start-up adaptation with 'run ADP.S' setting, the analog output is stepped up or down by the step change value of the manipulated variable (**Y.JMP** parameter). The controller waits for the response from the controlled system until a new stable state of the controlled variable is reached. The controller determines the control parameters from the course of the controlled variable. After the adaptation is completed, the controller issues the output value again which was active in manual mode before the adaptation.

Before the adaptation, the operating point of the manipulated variable must be known. If it is not known, it can be determined in the manual mode. To proceed, set the manipulated variable **Y** in manual mode so that the controlled variable **X** has the same value as the set point **W**. This output value is the operating point.

The step change of the manipulated variable must be large as possible and be located around the operating point (e.g. start value below the operating point and end value above it). On determining the step change value **Y.JMP** and the start value, make sure that the output value is within the range of the manipulated variable and that the controlled variable is within the measuring range. Furthermore, make sure the controlled variable for the process does not assume any impermissible values. Check this point before the adaptation: in manual mode set the output value after the step change and then the output value before the step change.

To run start-up adaptation, proceed as follows:

The compact controller is in the operating level.

Start-up and configuration at the device

1. In manual mode, set the manipulated variable **Y** to the operating point so that the controlled variable **X** has the same value as the set point **W**.
2. Raise the manipulated variable **Y**, for example by 10 % (with step change value of the manipulated variable **Y.JMP = 20 %**) and wait until the controlled variable **X** does not change anymore.
3. Check whether the controlled variable is within the permissible range.
4. Reduce the manipulated variable **Y**, for example by 20 % (with step change value of the manipulated variable **Y.JMP = 20 %**) and wait until the controlled variable **X** does not change anymore.
5. Check whether the controlled variable is within the permissible range.
6. In the TUNE menu, select **-CO- ADAP** function and set the step change value **Y.JMP**.
7. In the TUNE menu, select **-CO- ADAP** function. Select 'run ADP.S' to start the adaptation. How long the adaptation takes is determined by the time behavior of the controlled system. If the controlled variable does not reach an end value within five hours, the adaptation is automatically canceled.

After starting the adaptation, status messages on the start-up adaptation are displayed in the top row.

Messages

10	Adaptation started
20	Noise measurement (approx. 10 seconds)
40	Step-change value output ($Y = YPID + Y.JMP$) Wait for controlled system to react (step response)
41	Step-change value output ($Y = YPID + Y.JMP$) Wait for controlled system to settle
50	Returned to output value before starting adaptation Determining parameters
70, 71, 72, End	Adaptation finished

i Note

Press  key to cancel the adaptation.

If an error occurs during adaptation, the error appears on the display and the binary output for fault alarms is activated (see the 'Malfunctions' section).

8 Start-up and configuration with TROVIS-VIEW

The controller can be configured using the TROVIS-VIEW software.

8.1 Communication

8.1.1 Interface

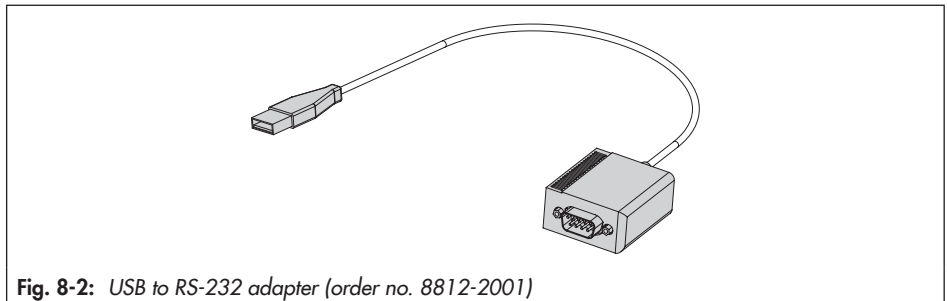
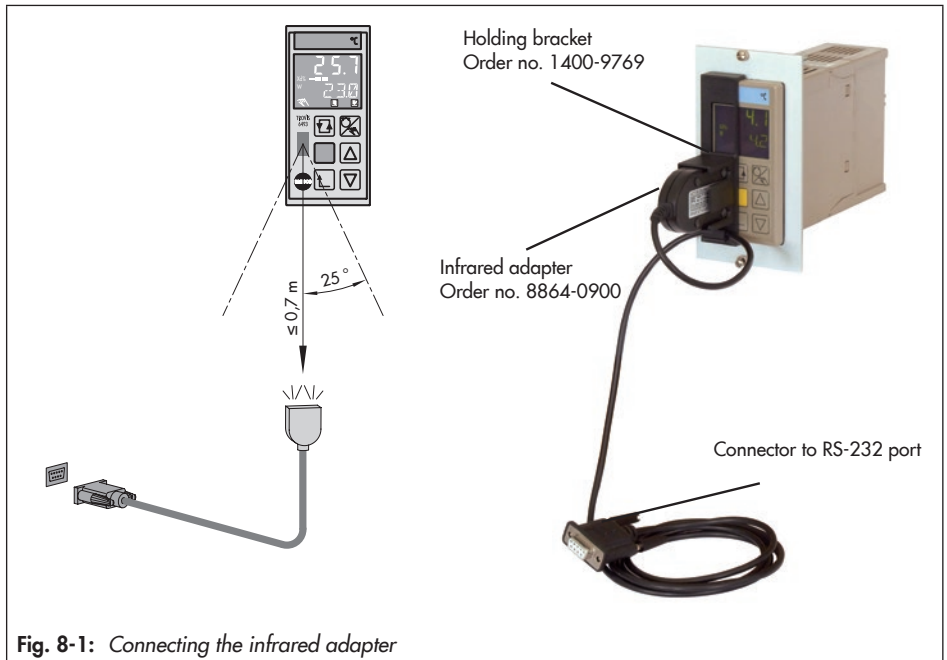

Start-up and configuration with TROVIS-VIEW

Connecting the infrared adapter

1. Connect the infrared adapter to the computer using the USB to RS-232 adapter.
2. Install the driver for USB to RS-232 adapter.

NOTICE

An IrDA driver will impair the functioning of TROVIS-VIEW.

An IrDA driver must not be installed on the computer on which TROVIS-VIEW is installed. Otherwise, TROVIS-VIEW will not run properly.

→ If such a driver is installed, deactivate the IR device in Windows® Control Panel or assign a different COM port.

Note

The driver can be downloaded from our website ► www.samsung.com > SERVICE & SUPPORT > Download > TROVIS-VIEW.

3. Start TROVIS-VIEW with device module TROVIS 6493.
4. Select 'Communication...' from the 'Options' menu. Click 'Connection settings' buttons and select the COM port.

Note

To ensure data transmission functions properly without the use of a bracket, place the infrared adapter so that the distance to the infrared interface does not exceed 0.7 m and that the max. angle 25° is kept (see Fig. 8-1). Make sure the transmission path is not obstructed.

Tip

We recommend using the infrared adapter with the corresponding bracket (see Fig. 8-1).

8.1.2 Addressing

If there is only one compact controller with an infrared interface in the send/receive range of the infrared adapter, data can be uploaded from the controller or downloaded to it directly. Addressing is not required.

If there are several controllers with infrared interfaces at the same point of installation, controllers must be addressed using their serial number since only one controller may communicate with the computer at one time.

i Note

The infrared adapter must be connected to the computer and aligned to the infrared interface of the compact controller (see the 'Operation' section).

How to proceed:

1. Select 'Addressing...' from the 'Device' menu.
The wizard for device addressing opens.
2. Select 'Several devices of the same type are within reach'.
The controllers within the reception range display their serial number.
3. Enter the serial number of the compact controller you want to address manually.

i Note

*The serial number is displayed on the compact controller in the I-O main group (**S-No**). It is also indicated on the nameplate (serial number, see the 'Markings on the device' section). After addressing is completed, the serial number appears in the info bar. If you want to configure another controller, repeat the addressing procedure.*

8.1.3 Communication readings on the display

CONN appears on the controller display while data are being read from the controller and written to the controller as well as in online mode. In the operating level, this reading appears in alternating sequence with the values for **W**, **W2**, **WE**, **Y** or **Xd**.

8.2 Folders in TROVIS-VIEW

8.2.1 Identification

The 'Identification' folder contains device-specific data read from the TROVIS 6493 Compact Controller and transferred to the software. The **System data (1)** and **System data (2)** fields allow you to describe a controller by entering short texts comprising a maximum of 30 characters per field (a to z, A to Z, 0 to 9, -).

These texts can be saved on the controller. Edited texts are only displayed on the TROVIS-VIEW software and printed on any associated documentation.

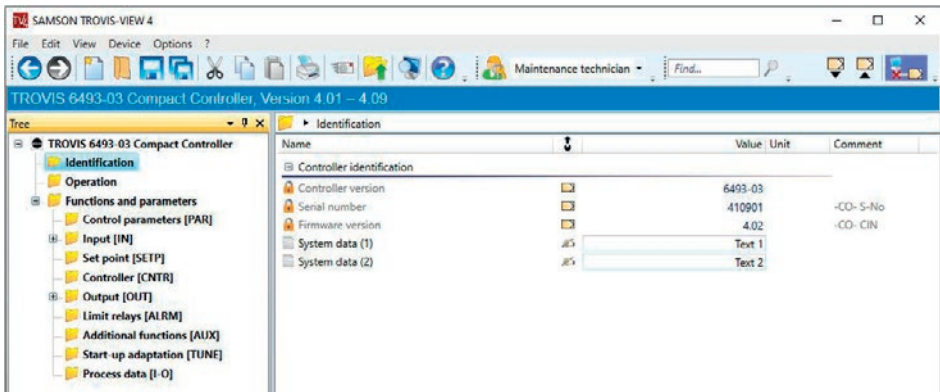

8.2.2 Operation

The 'Operation' folder contains all parameters and operating states also displayed in the controller's operating level. If an online connection has been established, current operating data are read from the controller and displayed in this folder. The values of the internal set points and the manual output value are set in the 'Operation' folder. Additionally, a set point switchover and manual/automatic switchover can be performed in this folder.

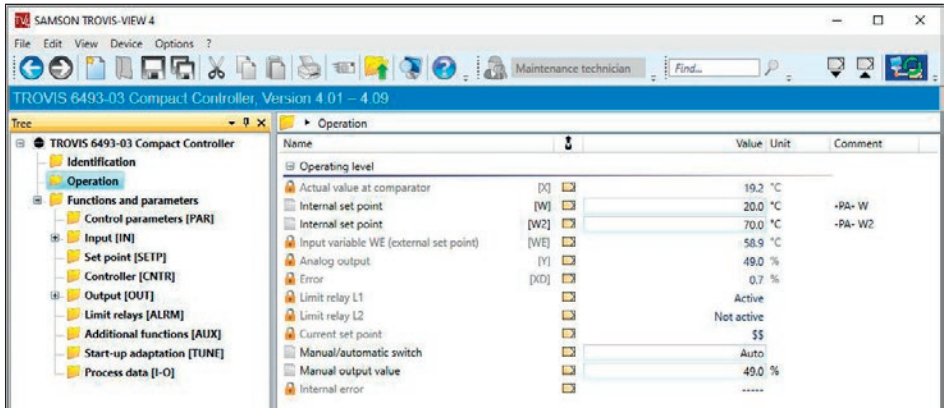

Set point switchover

Conditions for the set point switchover:

- The set points involved are activated in the controller (**SETP** main group), e.g. **W** = ON and **W2** = ON.
- If a set point switchover via the binary input **B11** is configured, the binary input must be deactivated during the switchover with TROVIS-VIEW.
- The infrared adapter must be connected to the computer and aligned to the infrared interface of the compact controller (see the 'Operation' section).

Example:

Switching over set points **W/W2**

1. Switch TROVIS-VIEW to offline mode.
2. Double-click **Current set point** to activate the data point.
An online connection is briefly established to the controller. The current set point is read.
3. Select the required set point.
The set point switchover takes place.

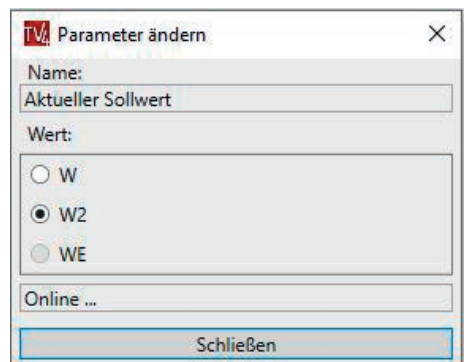

Start-up and configuration with TROVIS-VIEW

i Note

An infrared connection must exist during the switchover of the **Current set point**. Switchover only functions in offline mode.

Manual/automatic switchover

To change from manual to automatic operation, set **Manual/automatic switch** to 'Auto' and transfer the new setting to the controller.

i Note

Either transfer the **Manual/automatic switch** data point or the 'Operation' folder to the controller. The controller does not switch to automatic operation if the entire data record is transferred to the controller.

Internal error

→ Internal error data point (see the 'Malfunctions' section).

8.2.3 Functions and parameters

The 'Functions and parameters' folder and its subfolders contain all functions of the controller's operating level. The subfolders correspond to the main groups in the controller. Functions and parameters are listed in the folder. Functions are marked with the prefix **CO** (configuration) and parameters with the prefix **PA** (parameter). Parameters are listed below the function to which they belong.

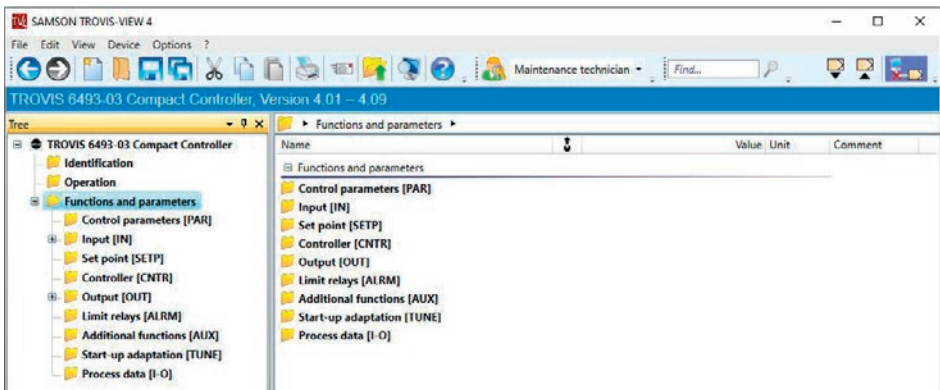

8.2.3.1 Control parameters [PAR]

The Control parameters [PAR] folder corresponds to the **PAR** main group of the controller. The control parameters **KP**, **TN**, **TV** and **Y.PRE** are set in this folder.

8.2.3.2 Input [IN]

The Input [IN] folder corresponds to the **IN** main group of the controller. All functions of the two analog inputs IN1 and IN2 are determined in this folder. The following settings can be made:

- Determining the type of input signal and the measuring range
- Signal monitoring
- Assigning analog inputs to the controlled variable **X** or external set point **WE**
- Units
- Filtering
- Root extraction
- Function generation

Assigning units

Units can be assigned to the controlled variable **X**, the internal set points **W/W2** and the external reference variable **WE** for documentation purposes. The following units can be selected:

- °C, degC, degF, K
- bar, mbar, psi
- kg/s, kg/min, kg/h
- l/s, l/min, l/h
- m
- %
- <special>

A user-defined unit can be assigned by selecting '<special>'.

A maximum of 10 characters (a to z, A to Z, 0 to 9, -) are available.

i Note

The units are only intended for documentation and are only saved in the TROVIS-VIEW file and not in the controller itself.

Example:

User-defined unit for the controlled variable **X**

1. Double-click **Unit X** to activate the data point.
2. Select '<special>' from the drop-down list.
3. Click [OK] to confirm.
A new row 'Unit X <special>' is created.
4. Double-click 'Unit X <special>' to activate the data point.
5. Enter the new unit in the pop-up window and confirm selection by clicking [OK].
The new unit is adopted.

The screenshot shows the SAMSON TROVIS-VIEW 4 software interface. The main window displays a tree view on the left with 'TROVIS 6493-03 Compact Controller' expanded to 'Input [IN]'. The main area shows a table of parameters with columns for Name, Value, Unit, and Comment. A 'Change parameters' dialog box is open over the 'Unit X <special>' row, showing the Name field with 'Unit X <special>' and the Unit field with '<special>'. The dialog also has fields for Range and Value, and OK/Cancel buttons.

Name	Value	Unit	Comment
Input signal IN1	4-20 mA		-CO- IN1
Lower measuring range value [IN1.MIN]	0.0	-Txt-	-PA- IN1.MIN
Upper measuring range value [IN1.MAX]	100.0	-Txt-	-PA- IN1.MAX
Input signal IN2	Pt 100 (-100 ... 500 °C)		-CO- IN2
Lower measuring range value [IN2.MIN]			-PA- IN2.MIN
Upper measuring range value [IN2.MAX]			-PA- IN2.MAX
Signal monitoring			-CO- MEAS
Switch to manual mode in case of signal failure	a.zA_Z0.9 -		-CO- MAN
Constant output value [Y1K1]			-PA- Y1K1
Assignment of X and WE to analog inputs			-CO- CLAS/X/WE
Unit X		<special>	For documentation only
Unit X <special>		-Txt-	For documentation only
Unit WE		°C	For documentation only
Unit X after function generation		°C	For documentation only
Unit WE after function generation		°C	For documentation only

8.2.3.3 Set point [SETP]

The Set point [SETP] folder corresponds to the **SETP** main group of the controller. The set points, set point switchover and set point ramps are set in this folder. In addition, it is possible to assign an input signal to the position feedback of an actuator or to the feedforward control.

8.2.3.4 Controller [CNTR]

The Controller [CNTR] folder corresponds to the **CNTR** main group of the controller. The dynamic behavior of the control output and the associated functions are set in this folder. This includes the direction of action of the calculated control signal, the error and the feedforward control added to the controlled variable.

8.2.3.5 Output [OUT]

The Output [OUT] folder corresponds to the **OUT** main group of the controller. The controller's output functions are set in this folder. It is possible to determine whether the controller is to work with a continuous-action or a switching output. Additionally, the configuration for on/off and three-step output is performed in this folder.

8.2.3.6 Limit relays [ALRM]

The Limit relays [ALRM] folder corresponds to the **ALRM** main group of the controller. The functions of the limit relays L1 and L2 are set in this folder.

8.2.3.7 Additional functions [AUX]

The Additional functions [AUX] folder corresponds to the **AUX** main group of the controller. The following functions are determined in this folder:

- Restart conditions after power failure
- Default settings
- Lock control keys
- Viewing angle of display
- Power line frequency
- Number of decimal places for variables directly relating to the analog inputs

Start-up and configuration with TROVIS-VIEW

The 'Reset to default settings' function in the AUX folder causes all parameters, functions and calibration data to be reset to their default settings.

The System data (1) and (2) saved in the controller are not cleared.

8.2.3.8 Start-up adaptation [TUNE]

The Start-up adaptation [TUNE] folder corresponds to the **TUNE** main group of the controller. It is possible to preset a start-up adaptation to automatically tune the control parameters **KP**, **TN** and **TV** in this folder. In addition, the start-up adaptation can be started or canceled.

i Note

The conditions for performing an adaptation are listed in the 'Start-up and configuration at the device' section.

Starting the adaptation

1. Open the 'Operation' folder.
2. Set manual mode:
→ Set 'Manual/automatic switch' to 'Manual' and transfer the new setting to the controller.
3. Determine the set point and transfer it to the controller.
4. In manual mode, set the controlled variable to match the set point.
5. Open the 'Start-up adaptation [TUNE]' folder.
6. Enter the step response in 'Step-change value of manipulated variable [Y.JMP]' field and transfer it to the controller.
7. Set 'Start-up adaptation' to 'Start'.
8. Right-click 'Start-up adaptation' and select 'Execute' from the context-sensitive menu. Adaptation is started.

Exiting or canceling the adaptation

1. Open the 'Start-up adaptation [TUNE]' folder.
2. Set 'Start-up adaptation' to 'Off'.
3. Right-click 'Start-up adaptation' and select 'Execute' from the context-sensitive menu. Adaptation is ended.

i Note

In online mode, the adaptation progress is displayed in 'Adaptation status'.

8.2.3.9 Process data [I-O]

The analog and binary input and output variables as well as the controller's internal variables are displayed in the View process data [I-O] folder.

Differences between this folder and the I-O main group of the controller:

- In the I-O main group under **ADJ**, zero and span of the analog inputs and of the analog output can be calibrated. This calibration cannot be performed in TROVIS-VIEW.
- The firmware version (**CIN**) and serial number (**S-No**) are displayed on the compact controller in the I-O main group. In TROVIS-VIEW, these numbers are displayed in the 'Operation' folder.

9 Operation



Operating level

While in operation, the controller is in the operating level. Key information on the control process is displayed in this level. The default reading shows the controlled variable **X**, error **Xd**, the currently valid set point **W**, **W2** or **WE**, the active limit relay as well as information on the three-step output, if applicable (see Fig. 9-1).



i Note

*Other variables, such as the error **Xd** in %, can be displayed instead of the currently valid set point. In this case, press the selector key until the required variable is displayed. The following variables can be selected: internal set point **W**, manipulated variable **Y**, error **Xd%** and, depending on the configuration in the SETP menu, the internal set point **W**, **W2** and the external set point **WE**.*

9.1 Setting the internal set point

-  → Selecting the internal set point **W** or **W2**
-  → Raise the set point.
-  → Lower the set point.

9.2 Switchover between set points

-  → Select set point **W**, **W2** or **WE**.
If a set point is not active, the set point name (**W**, **W2** or **WE**) blinks on the display.
-  → Activate set point.
The set point name (**W**, **W2**, **WE**) stops blinking.
The previously active set point is deactivated.

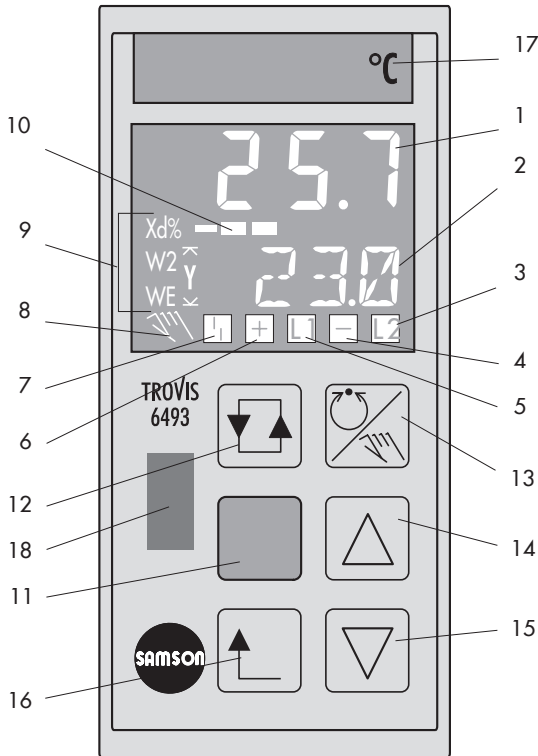





- | | | | | | |
|---|-----------------------|----|--|----|---|
| 1 | Controlled variable X | 9 | After pressing  , W, W2, Y or Xd is displayed with the value in 2 | 15 | Cursor key (decrease, scroll backwards) |
| 2 | W, W2, WE, Y or Xd | 10 | Bar reading of Xd in % | 16 | Escape key |
| 3 | Limit relay L2 active | 11 | Selector key | 17 | Label (exchangeable) |
| 4 | Three-step output - | 12 | Selector key | 18 | Infrared interface |
| 5 | Limit relay L1 active | 13 | Manual/automatic key | | |
| 6 | Three-step output + | 14 | Cursor key (increase, scroll forwards) | | |
| 7 | Error message | | | | |
| 8 | Hand icon | | | | |

Fig. 9-1: Operating keys and display

9.3 Switching over to manual mode and changing the manipulated variable

-  → Switch to manual mode.
The  icon and the manipulated variable **Y** are shown on the display.
-  → Raise the set point.
-  → Lower the set point.

Return to automatic mode.

-  → Change to automatic mode.
The hand icon is no longer displayed. The current set point is shown.

Note

Press  key to read the manipulated variable **Y**.

9.4 AUX menu, -CO- ST.IN: Reset to default settings

→ See Configuration Manual ► KH 6493.

The **Reset to default settings** function in the AUX menu causes all parameters, functions and calibration data to be reset. After the reset, the message **FrEE INIT** appears on the display.

-CO- ST.IN	Reset to default settings
FrEE INIT	OFF
All INIT	All functions, parameters and code number
FUnC INIT	All functions
PArA INIT	All parameters and code number
AdJ INIT	Calibration values for IN1, IN2, Y

9.5 AUX menu, -CO- VIEW: Set viewing angle of the display

The contrast for the top and bottom viewing angle of the display can be changed from Level 1 to Level 10 in the AUX menu.

→ See Configuration Manual ► KH 6493.

Tip

The default setting (Level 6) only needs to be changed in extreme installation situations.

-CO- VIEW	Top/bottom viewing angle of display
01 VIEW	Level 1
...	
06 VIEW	Level 6
...	
10 VIEW	Level 10

9.6 I-O menu: Process data

You can read various variables and data in this menu. In addition, you can calibrate zero and span for the analog inputs IN1 and IN2 as well as the analog output Y.

9.6.1 -CO- CIN: Firmware version

Read the firmware version

I-O	-CO- CIN	Firmware version
-----	----------	------------------

9.6.2 -CO- S-No: Serial number

Read the serial number

I-O	-CO- S-No	Serial number
-----	-----------	---------------

9.6.3 -CO- ANA: Show analog inputs and outputs

The analog values are shown in this function.

I-O	-CO- ANA	Analog values
	IN1	Analog input IN1
	IN2	Analog input IN2
	CO.VA	Controlled variable before function generation
	WE.VA	WE before function generation
	FE.CO	WE after function generation
	SP.CO	Set point at comparator
	YPID	YPID after limitation
	YOUT	Analog output

9.6.4 -CO- BIN: Show binary inputs and outputs

The states of the binary input and the binary outputs are shown in this function

I-O	-CO- BIN	Binary values
	BI1	Binary input BI
	BO1	Binary output BO1
	BO2	Binary output BO2

9.6.5 -CO- ADJ: Calibration of analog inputs and analog output

This functions allows you to calibrate the zero and span for the analog inputs and analog output.







The analog inputs and analog output are factory-calibrated.

A system-related user calibration can compensate for long lines, small wire cross-sections or tolerances of measuring transducers and final control elements. The user calibration can be reset to the factory calibration (AUX menu, **-CO- ST.IN** function, AdJ INIT setting, see section 9.4).











I-O	-CO- ADJ	Calibration
	AdJ IN1	Analog input IN1
	AdJ IN2	Analog input IN2
	AdJ YOUT	Analog output

Operation

Calibrating analog inputs:

1. Connect a high-precision meter at the input (IN1, IN2).
2. In the I-O menu, select the **ADJ** function.
3. Use the cursor keys (, ) to select the input you want to calibrate (**Adj IN1**, **Adj IN2**).
4. Confirm the input ().
You are prompted to enter the key number.
5. Enter the key number or continue by pressing .
6. Use the high-precision meter to set the input signal to the required lower range value.
Alternating reading: **ZERO** and **IN1 (IN2)**
7. Confirm lower range value ().
Reading: **0.0** and **ZERO**
8. Use the high-precision meter to set the input signal to the required upper range value.
Alternating reading: **SPAN** and **IN1 (IN2)**
9. Confirm upper range value ().
Reading: **100.0** and **SPAN**

Calibrating analog outputs:

1. Connect a high-precision meter at the analog output (Y).
2. In the I-O menu, select the **ADJ** function.
3. Use the cursor keys (, ) to select the output (**Adj YOUT**).
4. Confirm the output ().
You are prompted to enter the key number.
5. Enter the key number or continue by pressing .
6. Use the cursor keys (, ) to set the output so that the lower range value is indicated on the high-precision meter.
Alternating reading: **ZERO** and **YOUT**
7. Confirm lower range value ().
Reading: **0.0** and **ZERO**
8. Use the cursor keys (, ) to set the output so that the upper range value is indicated on the high-precision meter.
Alternating reading: **SPAN** and **YOUT**
9. Confirm upper range value ().
Reading: **100.0** and **SPAN**

10 Malfunctions

DANGER

Risk of electric shock while performing electrical connection.

For electrical installation, you are required to observe the relevant electrotechnical regulations of the country of use as well as the regulations of the local power suppliers.

→ Only allow properly trained and qualified personnel to perform the work.

NOTICE

Risk of damage to the compact controller due to incorrectly performed work.

→ Only properly trained personnel appropriately qualified to carry out such tasks must be allowed to perform corrective action.

10.1 Troubleshooting

When an error occurs, it is indicated on the display and causes the binary output for error indication to be activated. As soon as an error has been corrected, it is no longer displayed. The following list contains error messages, possible causes and the recommended action.

Tip

We recommend for any errors not described in detail to switch off the supply voltage and to wait approx. five seconds before switching it on again.

Table 10-1: Error list · Error messages shown on the device

Error	Possible reasons	Recommended action
1 ERR	EEPROM access not possible	→ Return device to SAMSON for repair.
2 ERR	EEPROM cannot be programmed	
3 ERR	Default calibration lost	
4 ERR	Functions changed without user intervention	→ Check the function settings.
5 ERR	Parameters changed without user intervention	→ Check the parameter settings.
6 ERR	Position of internal and external set point unknown	→ Select the external/internal set point.

Malfunctions





Error	Possible reasons	Recommended action
7 ERR	User calibration data changed without user intervention	→ Recalibrate inputs/output.
30 ERR	Adaptation takes too long	The adaptation is completed after five hours at the latest.
31 ERR	No parameters could be determined during the start-up adaptation.	→ Change control parameters KP , TN , TV and Y.JMP and restart start-up adaptation.
32 ERR	The signal at the X input is smaller than 0 % or greater than 100 % during adaptation.	→ Change Y.JMP and restart start-up adaptation.
33 ERR	Too much noise interference during adaptation	→ Increase Y.JMP and restart start-up adaptation.
34 ERR	Selected PID setting impedes adaptation.	→ In -CO- C.PID function, select the control algorithm P, PI or PID and restart start-up adaptation.
35 ERR	The control signal Y is smaller than 0 % or greater than 100 % during adaptation.	→ Change Y.JMP and restart start-up adaptation.
36 ERR	Error during adaptation	→ Restart start-up adaptation.
256 ERR	Basic calibration missing	→ Return device to SAMSON for repair.
__o1 	Upper limit violation of rated signal range at analog input IN1 or at analog inputs IN1 and IN2	The error message depends on how -CO-MEAS is configured (▶ KH 6493).
__u1 	Lower limit violation of rated signal range at analog input IN1 or at analog inputs IN1 and IN2	
__o2 	Upper limit violation of rated signal range at analog input IN2	The error message depends on how -CO-MEAS is configured (▶ KH 6493).
__u2 	Lower limit violation of rated signal range at analog input IN2	

Table 10-2: Error list · Error messages in TROVIS-VIEW

Error	Possible reasons	Recommended action
Device does not respond.	Interface incorrectly assigned	<ul style="list-style-type: none"> ➔ Select 'Communication ...' from the 'Options' menu to open the Communication window. Click 'Settings' button and assign a free serial COM port of the computer. ➔ Repeat the previous action.
	The infrared adapter is not aligned with infrared interface on the controller or the adapter and interface are positioned too far apart.	➔ Realign the infrared adapter (see the 'Operation' section) and repeat previous action.
	Transmission path between infrared connections is blocked or one of the connections is obstructed.	➔ Remove obstacle or blockage and repeat the previous action.
	The infrared adapter is not connected to the computer.	➔ Connect the infrared interface to the computer and repeat the previous action.
	Serial number for infrared addressing does not match the serial number of the device.	➔ Select the configuration with the correct serial number.
Cannot open COM port.	The selected interface is already used by a different software, for example.	➔ Select 'Communication ...' from the 'Options' menu to open the Communication window. Click 'Settings' button and assign a free serial COM port of the computer.
	The serial COM port of the computer is not assigned correctly.	
No complete record exists.	The controller data have not been read out.	➔ Either first read data from the controller and continue or continue directly.
	Only open folders are updated in online mode and not the entire data records.	

10.2 Error messages generated by the compact controller

Error messages saved in the error memory of the controller can be uploaded and read in TROVIS-VIEW. The internal errors generated by the controller and errors that occurred during a start-up adaptation are shown.

The existence of an error message is indicated by the **Internal error** data point in the 'Operation' and 'Start-up adaptation [TUNE]' folders.

If an error message (ERR) has been generated by the controller and it has been read out, a temporary 'Error messages' folder containing the incoming error messages is created in the 'Operation' and 'Start-up adaptation [TUNE]' folders.

To clear the error messages in the controller, double-click the **Reset all internal errors** data point in the 'Error messages' folder. Perform the reset during online data transmission to the controller.

10.3 Emergency action

The control function no longer works after device failure. In this case, isolate and shut-off valves.

Plant operators are responsible for emergency action to be taken in the plant.



Tip

Emergency action in the event of valve failure is described in the associated valve documentation.

11 Servicing

The work described in this section is only to be performed by personnel appropriately qualified to carry out such tasks.

We recommend inspection and testing according to Table 11-1.

i Note

The compact controller was checked by SAMSON before it left the factory.

- *The product warranty becomes void if service or repair work not described in these instructions is performed without prior agreement by SAMSON's After-sales Service.*
- *Only use original spare parts by SAMSON, which comply with the original specifications.*

Table 11-1: Recommended inspection and testing

Inspection and testing	Action to be taken in the event of a negative result
Check the markings, labels and nameplates on the compact controller for their readability and completeness.	➔ Immediately renew damaged, missing or incorrect nameplates or labels.
	➔ Clean any inscriptions that are covered with dirt and are illegible.
Check the connecting cables.	➔ If lines are loose, tighten the screws at the terminal (see the 'Installation' section).
	➔ Renew damaged lines.
Check the plug-on screw terminals to ensure they are correctly inserted.	➔ Insert plug-on screw terminals that are not correctly inserted (see the 'Installation' section).
Check panel mounting.	➔ If the device is mounted too loosely or too tightly, adjust the threaded rods (see the 'Installation' section).
	➔ Replace a defective seal.

12 Decommissioning

The work described in this section is only to be performed by personnel appropriately qualified to carry out such tasks.

DANGER

Risk of electric shock while performing electrical connection.

For electrical installation, you are required to observe the relevant electrotechnical regulations of the country of use as well as the regulations of the local power suppliers.

- *Before connecting wiring, performing any work on the compact controller or opening the controller, disconnect the supply voltage and protect it against unintentional reconnection.*
 - *Only use power interruption devices that can be protected against unintentional reconnection of the power supply.*
 - *Do not remove any covers to perform adjustment work on live parts.*
-

To put the compact controller out of operation, the controller must be disconnected from the electrical power supply:

- *Disconnect the supply voltage and protect it against unintentional reconnection.*

13 Removal

The work described in this section is only to be performed by personnel appropriately qualified to carry out such tasks.

1. Remove infrared adapter and its bracket, if mounted.
2. Unscrew the threaded rods from the compact controller.
3. Remove the mounting clamps.
4. Pull the compact controller out of the panel.

14 Repairs

A defective compact controller must be repaired or replaced.

NOTICE

Risk of controller damage due to incorrect service or repair work.

- *Do not perform any repair work on your own.*
 - *Contact SAMSON's After-sales Service for repair work.*
-

14.1 Returning devices to SAMSON

Defective controllers can be returned to SAMSON for repair.

Proceed as follows to return devices to SAMSON:

1. Put the compact controller out of operation (see the 'Decommissioning' section).
2. Remove the compact controller (see the 'Removal' section).
3. Proceed as described on the Returning goods page of our website
 - ▶ www.samsongroup.com > Service & Support > After-sales Service > Returning goods

15 Disposal



SAMSON is a producer registered at the following European institution ► <https://www.ewrn.org/national-registers/national-registers>.
WEEE reg. no.:
DE 62194439/FR 025665

- Observe local, national and international refuse regulations.
- Do not dispose of components, lubricants and hazardous substances together with your other household waste.



We can provide you with a recycling passport according to PAS 1049 on request. Simply e-mail us at offersaleservice@samsongroup.com giving details of your company address.



On request, we can appoint a service provider to dismantle and recycle the product as part of a distributor take-back scheme.

16 Certificates

The following certificates are included on the next pages:

- EU declaration of conformity
- TR CU certificate

The certificates shown were up to date at the time of publishing. The latest certificates can be found on our website:

▶ www.samsongroup.com > Products & Applications > Product selector > Automation Systems > 6493

EU declaration of conformity

SMART IN FLOW CONTROL



**EU Konformitätserklärung / EU Declaration of Conformity /
Déclaration UE de conformité**

Die alleinige Verantwortung für die Ausstellung dieser Konformitätserklärung trägt der Hersteller/
This declaration of conformity is issued under the sole responsibility of the manufacturer/
La présente déclaration de conformité est établie sous la seule responsabilité du fabricant.
Für das folgende Produkt / For the following product / Nous certifions que le produit

**Kompaktregler / Compact Controller / Régulateur compact
Typ/Type/Type TROVIS 6493**

wird die Konformität mit den einschlägigen Harmonisierungsrechtsvorschriften der Union bestätigt/
the conformity with the relevant Union harmonisation legislation is declared with/
est conforme à la législation d'harmonisation de l'Union applicable selon les normes:

EMC 2014/30/EU	EN 61000-6-2:2005, EN 61000-6-3:2010 +A1:2011, EN 61326:2013
LVD 2014/35/EU	EN 60730-1:2016, EN 61010-1:2010
RoHS 2011/65/EU	EN 50581:2012

Hersteller / Manufacturer / Fabricant:

SAMSON AKTIENGESELLSCHAFT
Weismüllerstraße 3
D-60314 Frankfurt am Main
Deutschland/Germany/Allemagne

Frankfurt / Francfort, 2017-07-29

Im Namen des Herstellers/ On behalf of the Manufacturer/ Au nom du fabricant.

i.V. Gert Nahler

Gert Nahler
Zentralabteilungsleiter/Head of Department/Chef du département
Entwicklung Automation und Integrationstechnologien/
Development Automation and Integration Technologies

i.V. H. Zager

Hanno Zager
Leiter Qualitätssicherung/Head of Quality Management/
Responsable de l'assurance de la qualité

es_54933-0_de_en_fr_m07.pdf

TR CU certificate

ЕВРАЗИЙСКИЙ ЭКОНОМИЧЕСКИЙ СОЮЗ

СЕРТИФИКАТ СООТВЕТСТВИЯ

№ ЕАЭС RU C-DE.ЭА11.В.00051/19

Серия **RU** № **0197360**

ОРГАН ПО СЕРТИФИКАЦИИ Общества с ограниченной ответственностью «ТМС РУС». Место нахождения (адрес юридического лица): Российская Федерация, 127083, город Москва, улица Верхняя Масловка, дом 20, строение 2; адрес места осуществления деятельности: Российская Федерация, 127083, город Москва, улица Верхняя Масловка, дом 20, строение 2, помещения № 18, 28. Аттестат аккредитации № РОСС RU.0001.113ЭА11 от 02.07.2015. Номер телефона: +7 (495) 221-18-04; адрес электронной почты: info@tms-rs.ru.

ЗАЯВИТЕЛЬ Общество с ограниченной ответственностью «Самсон Контролс». Место нахождения (адрес юридического лица) и адрес места осуществления деятельности: Российская Федерация, 109544, город Москва, бульвар Энтузиастов, дом 2, этаж 5, комната 11. ОГРН 1037700041026. Номер телефона: +7 (495) 777-45-45; адрес электронной почты: samson@samson.ru.

ИЗГОТОВИТЕЛЬ «SAMSON AG Mess- und Regeltechnik». Место нахождения (адрес юридического лица) и адрес места осуществления деятельности по изготовлению продукции: Weismüllerstraße 3, D-60314 Frankfurt am Main, Германия.

ПРОДУКЦИЯ Регуляторы электронные систем локального и центрального отопления, регуляторы промышленные TROVIS, типы 5573, 5575, 5576, 5579, 5610, 6493, 6495. Изготовление в соответствии со стандартами, указанными в приложении к сертификату соответствия на бланке № 0676636. Серийный выпуск.

КОД ТН ВЭД ВАЭС 9032 89 000 0

СООТВЕТСТВУЕТ ТРЕБОВАНИЯМ технических регламентов Таможенного союза «О безопасности низковольтного оборудования» (ТР ТС 004/2011), «Электромагнитная совместимость технических средств» (ТР ТС 020/2011).

СЕРТИФИКАТ СООТВЕТСТВИЯ ВЫДАН НА ОСНОВАНИИ протокола сертификационных испытаний № 190919-008-009-02/ИР от 28.10.2019, выданного испытательной лабораторией Общества с ограниченной ответственностью «Инновационные решения», аттестат аккредитации РОСС RU.0001.21AB90; акта о результатах анализа состояния производства № 00062-А от 04.07.2019 органа по сертификации Общества с ограниченной ответственностью «ТМС РУС»; руководства по эксплуатации 4218-5570-5610-6490-2018.РЭ. Схема сертификации – 1с.

ДОПОЛНИТЕЛЬНАЯ ИНФОРМАЦИЯ Стандарты, в результате применения которых на добровольной основе обеспечивается соблюдение требований технических регламентов, указаны в приложении к сертификату соответствия на бланке № 0676637. Назначенный срок службы – 12 лет. Назначенный срок хранения – 2 года. Условия хранения указаны в руководстве по эксплуатации 4218-5570-5610-6490-2018.РЭ.

СРОК ДЕЙСТВИЯ С 25.12.2019 **ПО** 24.12.2024

ВКЛЮЧИТЕЛЬНО

Руководитель (уполномоченное лицо) органа по сертификации *Назарова* Назарова Лилия Юрьевна (И.О.Ф.)

Эксперт (эксперт-аудитор) (эксперты (эксперты-аудиторы)) *М.П.* М.П. Ходоров Владимир Игоревич (И.О.Ф.)

ТМС
RU
C-DE.ЭА11.В.00051/19

ЕВРАЗИЙСКИЙ ЭКОНОМИЧЕСКИЙ СОЮЗ

ПРИЛОЖЕНИЕ

К СЕРТИФИКАТУ СООТВЕТСТВИЯ № ЕАЭС RU C-DE.ЭА11.В.00051/19

Серия **RU** № **0676636** Лист 1 из 1

Стандарты, в соответствии с которыми изготавливается продукция

Обозначение стандарта	Наименование стандарта
IEC 60730-1:2013 / Cor. 1:2014	Automatic electrical controls for household and similar use. Part 1. General requirements. Corrigendum 1
EN 50344-1:2002	Routine tests for controls within the scope of the EN 60730 series. General requirements
EN 55032:2012	Electromagnetic compatibility of multimedia equipment - Emission requirements
EN 61000-6-1:2007	Electromagnetic compatibility (EMC) - Part 6-1: Generic standards - Immunity for residential, commercial and light-industrial environments
IEC 61000-6-2:2016	Electromagnetic compatibility (EMC). Part 6-2: Generic standards. Immunity for industrial environments
EN 61000-6-3:2007	Electromagnetic compatibility (EMC). Part 6-3: Generic standards. Emission standard for residential, commercial and light-industrial environments
IEC 61010-1:2010	Safety requirements for electrical equipment for measurement, control, and laboratory use. Part 1: General requirements
EN 61326-1:2013	Electrical equipment for measurement, control and laboratory use. EMC requirements. Part 1: General requirements

Руководитель (уполномоченное лицо) органа по сертификации

Л.И. Назарова
(подпись)



Назарова Лилия Юрьевна
(Ф.И.О.)

Эксперт (эксперт-аудитор) (эксперты (эксперты-аудиторы))

В.И. Ходоров
(подпись)

М.П. Ходоров Владимир Игоревич
(Ф.И.О.)

ЕВРАЗИЙСКИЙ ЭКОНОМИЧЕСКИЙ СОЮЗ

ПРИЛОЖЕНИЕ

К СЕРТИФИКАТУ СООТВЕТСТВИЯ № ЕАЭС RU C-DE.ЭА11.В.00051/19

Серия **RU** № **0676637** Лист 2 из 2

Стандарты, в результате применения которых на добровольной основе обеспечивается соблюдение требований технического регламента

Обозначение стандарта	Наименование стандарта
ГОСТ IEC 61010-1-2014	Безопасность электрических контрольно-измерительных приборов и лабораторного оборудования. Часть 1. Общие требования
ГОСТ Р 51522.1-2011 (МЭК 61326-1:2005) подразделы 6.2 и 7.2	Электрическое оборудование для измерения, управления и лабораторного применения. Часть 1. Общие требования и методы испытаний
ГОСТ 30804.6.1-2013 (IEC 61000-6-1:2005) раздел 8	Совместимость технических средств электромагнитная. Устойчивость к электромагнитным помехам технических средств, применяемых в жилых, коммерческих зонах и производственных зонах с малым энергопотреблением. Требования и методы испытаний
ГОСТ 30804.6.3-2013 (IEC 61000-6-3:2006) раздел 7	Совместимость технических средств электромагнитная. Электромагнитные помехи от технических средств, применяемых в жилых, коммерческих зонах и производственных зонах с малым энергопотреблением. Нормы и методы испытаний

Руководитель (уполномоченное лицо) органа по сертификации
 Эксперт (эксперт-аудитор) (эксперты (эксперты-аудиторы))

Л.И. Назарова
 (подпись)

М.П. Ходоров
 (подпись)



Назарова Лилия Юрьевна (И.О.)
 Ходоров Владимир Игоревич (И.О.)

АО «Центр сертификации Евразийского экономического союза» (ЦС) - Москва, ул. Мясницкая, д. 20, стр. 1, 4-й этаж. Контактный телефон: +7 (495) 660-0000. Факс: +7 (495) 660-0001. E-mail: info@tms-rus.ru

17 Annex A (configuration guide)

The functions and parameters are described in detail in the Configuration Manual
▶ KH 6493.

17.1 Abbreviations





- X Controlled variable
- Y Manipulated variable
- W Internal set point
- W2 Internal set point
- WE External set point, feedforward control input value, external position feedback
- Xd Error
- ⚡ Minimum value of a variable
- ⚡ Maximum value of a variable

17.2 Configuration list

→ The functions and parameters are described in detail in the Configuration Manual ► KH 6493.





Menu	Function -CO-	Setting options ¹⁾	Description of functions	Parameter level -PA-
Control parameters				
PAR				
Input				
IN	IN1 Input signal IN1	0–20 mA	0 to 20 mA	IN1/mA
		4–20 mA	4 to 20 mA	IN1/mA
		0–10 V	0 to 10 V	IN1/V
		2–10 V	2 to 10 V	IN1/V
		100 PT	Pt 100 (–100 ... +500 °C)	IN1/PT
		1000 PT	Pt 1000 (–100 ... +500 °C)	IN1/PT
		100 NI	Ni 100 (–60 ... +250 °C)	IN1/NI
		1000 NI	Ni 1000 (–60 ... +250 °C)	IN1/PT
		0–1 KOHM	0 to 1000 Ω	IN1/KOHM
	IN2 Input signal IN2	0–20 mA	0 to 20 mA	IN2/mA
		4–20 mA	4 to 20 mA	IN2/mA
		0–10 V	0 to 10 V	IN2/V
		2–10 V	2 to 10 V	IN2/V
100 PT		Pt 100 (–100 ... +500 °C)	IN2/PT	
1000 PT		Pt 1000 (–100 ... +500 °C)	IN2/PT	
100 NI		Ni 100 (–60 ... +250 °C)	IN2/NI	
1000 NI	Ni 1000 (–60 ... +250 °C)	IN2/PT		
0–1 KOHM	0 to 1000 Ω	IN2/KOHM		
MEAS Signal monitoring	oFF ME.MO	OFF		noPA MEAS/ME.MO
	IN1 ME.MO	Analog input IN1		
	IN2 ME.MO	Analog input IN2		
	ALL ME.MO	Analog inputs IN1 and IN2		

¹⁾ Default setting is in **bold** print.

.....  ↓ or  →  ↓ and  , followed by  ↵

Parameter selection	Parameter name	Value range ¹⁾
---------------------	----------------	---------------------------

KP	Proportional-action coefficient	[0.1 ... 1.0 ... 100.0]
TN	Reset time	[1 ... 120 ... 9999 s]
TV	Derivative-action time	[1 ... 10 ... 9999 s]
Y.PRE	Operating point	[-10.0 ... 0.0 ... +110.0 %]

 IN1	Lower measuring range value	[-999.0 ... 0.0 ...  IN1]
 IN1	Upper measuring range value	[ IN1 ... 100.0 ... 9999] ²⁾

 IN2	Lower measuring range value	[-999.0 ... 0.0 ...  IN2]
 IN2	Upper measuring range value	[ IN2 ... 100.0 ... 9999] ²⁾

No parameters

¹⁾ Default setting is in **bold** print.



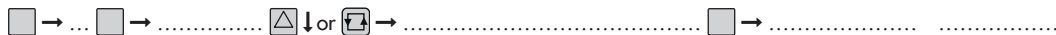

²⁾ Decimal place depends on DP function (AUX menu)

















Annex A (configuration guide)



Menu	Function -CO-	Setting options ¹⁾	Description of functions	Parameter level -PA-
IN	MAN Switch to manual mode in case of signal failure	off FAIL F01 FAIL F02 FAIL	OFF With constant output value Y1K1 With last manipulated variable value	MAN/FAIL
	CLAS Assignment of X to analog inputs	In2 X In1 X	X = IN2 X = IN1	noPA CLAS/X
	Assignment of WE to analog inputs	In1 WE In2 WE	WE = IN1 WE = IN2	noPA CLAS/WE
	DI.FI Filtering input variable X	off X on X	OFF ON	DI.FI/X
	Filtering input variable WE	off WE on WE	OFF ON	DI.FI/WE
	SQR Root extraction input variable X	off X on X	OFF ON	noPA SQR/X
	Root extraction input variable WE	off WE on WE	OFF ON	noPA SQR/WE
	FUNC Function generation input variable X	off X on X	OFF ON	FUNC/X
	Function generation input variable WE	off WE on WE	OFF ON	FUNC/WE

¹⁾ Default setting is in **bold** print.

.....  ↓ or  →  ↓ and  , followed by  ↵

Parameter selection	Parameter name	Value range ¹⁾
Y1K1	Constant output value	[-10.0 ... +110 %]
No parameters		
No parameters		
TS.X	Time constant X filter	[0.1 ... 1.0 ... 100.0 s]
TS.WE	Time constant WE filter	[0.1 ... 1.0 ... 100.0 s]
No parameters		
No parameters		
MIN	Lower output signal measuring range value	[-999.0 ... 0.0 ... MAX] ²⁾
MAX	Upper output signal measuring range value	[MIN ... 100.0 ... 9999] ²⁾
K1.X	Input value 1	[ IN1 ...  IN1], [ IN2 ...  IN2]
K1.Y	Output value 1	[MIN ... MAX]
...
K7.X	Input value 7	[ IN1 ...  IN1], [ IN2 ...  IN2]
K7.Y	Output value 7	[MIN ... MAX]
MIN	Lower output signal measuring range value	[-999.0 ... 0.0 ... MAX] ²⁾
MAX	Upper output signal measuring range value	[MIN ... 100.0 ... 9999] ²⁾
K1.X	Input value 1	[ IN1 ...  IN1], [ IN2 ...  IN2]
K1.Y	Output value 1	[MIN ... MAX]
...
K7.X	Input value 7	[ IN1 ...  IN1], [ IN2 ...  IN2]
K7.Y	Output value 7	[MIN ... MAX]



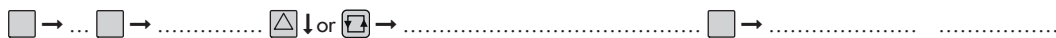

¹⁾ Default setting is in **bold** print.²⁾ Decimal place depends on DP function (AUX menu)

















Annex A (configuration guide)



Menu	Function -CO-	Setting options ¹⁾	Description of functions	Parameter level -PA-	
Set point					
SETP	SP.VA Internal set point W	on W	ON	SP.VA/W	
	Internal set point W2	oFF W2 on W2	OFF ON	P.VA/W2	
	Input variable WE	oFF WE on WE	OFF	External set point WE	noPA SP.VA/WE
		F01 WE	Input for external feedback with three-step output		
	F02 WE	Input for feedforward control			
SP.FU	Set point ramp	oFF RAMP	OFF	SP.FU/RAMP	
		F01 RAMP	Started with actual value by binary input BI1		
		F02 RAMP	Started with WIRA by binary input BI1		
	F03 RAMP	Without start conditions			
Set point switchover	oFF CH.SP	OFF	W(W2)/WE by binary input BI1 W/W2 by binary input BI1	noPA SP.VA/CH.SP	
	F01 CH.SP				
	F02 CH.SP				

¹⁾ Default setting is in **bold** print.

.....  ↓ or  →  ↓ and  , followed by 

Parameter selection	Parameter name	Value range ¹⁾
W	Internal set point	[ WRAN ... 0.0 ...  WRAN]
 WINT	Lower measuring range value W/W2	[-999 ... 0.0 ...  WINT]
 WINT	Upper measuring range value W/W2	[ WINT ... 100.0 ... 9999]
 WRAN	Lower adjustment limit W/W2	[ WINT ... 0.0 ...  WRAN]
 WRAN	Upper adjustment limit W/W2	[ WRAN ... 100.0 ...  WINT] ²⁾
W2	Internal set point	[ WRAN ... 0.0 ...  WRAN] ²⁾
No parameters		
TSRW	Running time	[1 ... 10 ... 9999 s]
WIRA	Initial value	[ WINT ... 0.0 ...  WINT] ²⁾
No parameter		

¹⁾ Default setting is in **bold** print.



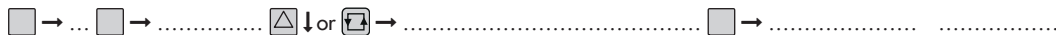

²⁾ Decimal place depends on DP function (AUX menu)

Annex A (configuration guide)



Menu	Function -CO-	Setting options ¹⁾	Description of functions	Parameter level -PA-
Controller				
CNTR	C.PID Control algorithm	P CP.YP PI CP.YP Pd CP.YP Pid CP.YP PPI CP.YP	P behavior PI behavior PD behavior PID behavior P ² behavior	C.PID/CP.YP C.PID/CP.YP C.PID/CP.YP C.PID/CP.YP C.PID/CP.YP
	SIGN Inversion error XD	dir.d XD in.d XD	Not inverted Inverted	noPA SIGN/XD
	D.PID Assignment D element control output	F01 DP.YP F02 DP.YP	To error To controlled variable	noPA D.PID/DP.YP
	CH.CA Control mode selection P(D)/PI(D)	oFF CC.P F01 CC.P F02 CC.P	OFF By error By set point	CH.CA/CC.P CH.CA/CC.P
	M.ADJ Operating point setting (manual mode) for YPID	oFF MA.YP on MA.YP	OFF ON	noPA M.ADJ/MA.YP
	DIRE Direction of action manipulated variable	dir.d DI.AC in.d DI.AC	Direct Inverted	noPA DIRE/DI.AC
F.FOR Feedforward control	oFF FECO P05 FECO nE6 FECO	Deactivated With positive sign With negative sign	F.FOR/FECO F.FOR/FECO	
AC.VA Increase/decrease actual value	oFF IN.DE bi1 IN.DE	Deactivated By binary input BI	AC.VA/IN.DE	

¹⁾ Default setting is in **bold** print.

.....  ↓ or  →  ↓ and  , followed by  ↵

Parameter selection	Parameter name	Value range ¹⁾
KP	Proportional-action coefficient	[0.1 ... 1.0 ... 100.0]
TN	Reset time	[1 ... 120 ... 9999 s]
TV	Derivative-action time	[1 ... 10 ... 9999 s]
TVK1	Derivative-action gain	[0.10 ... 1.00 ... 10.00]
Y.PRE	Operating point	[-10.0 ... 0.0 ... +110.0]
DZXD	Dead band error XD	[0.0 ... 110 %]
▼ DZXD	Min. effective error XD	[- 110 % ... ▲ DZXD]
▲ DZXD	Max. effective error XD	[▼ DZXD ... 110.0 %]
No parameters		
No parameters		
CLI.P	Max. limit for PI(D) control	[-110.0 ... +10.0 ... +110.0 %]
CLI.M	Min. limit for PI(D) control	[-110.0 ... -10.0 ... +110.0 %]
No parameter		
No parameters		
FC.K1	Constant 1 (feedforward control)	[0.0 ... 110.0 %]
FC.K2	Constant 2 (feedforward control)	[0.0 ... 1.0 ... 100.0]
FC.K3	Constant 3 (feedforward control)	[-110.0 ... 0.0 ... +110.0 %]
AV.K1	Constant in percent (\pm process variable)	[-110.0 ... 0.0 ... +110.0 %]

¹⁾ Default setting is in **bold** print.

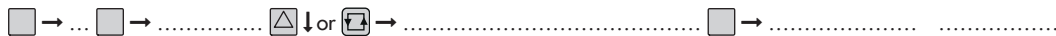

Annex A (configuration guide)



Menu	Function -CO-	Setting options ¹⁾	Description of functions	Parameter level -PA-
Output functions				
OUT	SAFE Activate constant output value	oFF SA.VA bi1 SA.VA	OFF By binary input BI1	SAFE/SA.VA
	MA.AU Manual/automatic switchover	oFF CH.MA bi1 CH.MA	OFF By binary input BI1	noPA MA.AU/CH.MA
	Y.LIM Control signal limitation YPID	oN LI.YP	ON	Y.LIM/LI.YP
	RAMP Manipulated variable ramp/limitation of rate of change for manipulated variable	oFF RA.YP F01 RA.YP F02 RA.YP F03 RA.YP F04 RA.YP F05 RA.YP	OFF Ramp increasing, start with -10 % by BI1 Ramp increasing/decreasing, start with Y1RA by BI1 Limitation when manipulated variable decreases and increases Limitation when manipulated variable increases Limitation when manipulated variable decreases	RAMP/RA.YP
	BLOC Locking manipulated variable YPID	oFF BL.YP on BL.YP	OFF By binary input BI1	noPA BLOC/BL.YP
	FUNC Function generation manipulated variable	oFF FU.YP on FU.YP	OFF ON	FUNC/FU.YP
	Y.VA Signal range for analog output Y	oFF Y 0-20 mA 4-20 mA 0-10 V 2-10 V	OFF 0 to 20 mA 4 to 20 mA 0 to 10 V 2 to 10 V	Fno PA Y.VA/Y no PA Y.VA/mA no PA Y.VA/mA no PA Y.VA/V no PA Y.VA/V

¹⁾ Default setting is in **bold** print.

.....  ↓ or  →  ↓ and  , followed by  ←





Parameter selection	Parameter name	Value range ¹⁾
Y1K1	Constant output value	[-10.0 ... 0.0 ... +110.0 %]
No parameters		
 Y	Min. manipulated variable	[-10.0 ... 0.0 ... +110.0 %]
 Y	Max. manipulated variable	[-10.0 ... + 100.0 ... +110.0 %]
TSRA	Running time	[1 ... 9999 s]
Y1RA	Initial value	[-10.0 ... 0.0 ... +110.0 %]
No parameter		
K1.X	Input value 1	[-10.0 ... 0.0 ... +110.0 %]
K1.Y	Output value 1	[-10.0 ... 0.0 ... +110.0 %]
...
K7.X	Input value 7	[-10.0 ... 0.0 ... +110.0 %]
K7.Y	Output value 7	[-10.0 ... 0.0 ... +110.0 %]
No parameter		

¹⁾ Default setting is in **bold** print.

Annex A (configuration guide)

Menu	Function -CO-	Setting options ¹⁾	Description of functions	Parameter level -PA-		
OUT	Y.SRC Source for analog output Y	on Y.PID on Y.X on Y.WE on Y.XD	Output YPID Input X Input WE Error XD	noPA Y.SRC/Y.PID noPA Y.SRC/Y.X noPA Y.SRC/Y.WE noPA Y.SRC/Y.XD		
	CALC Mathematical adaptation analog output Y	oFF CA.Y on CA.Y POS CA.Y nE6 CA.Y	OFF (no output signal) Without condition With positive sign With negative sign	CALC/CA.Y CALC/CA.Y CALC/CA.Y		
C.OUT On/off or three-step output		oFF 2/3.S on 2.STP i.Fb 3.STP	OFF On/off output Three-step output with internal feedback	C.OUT/2/3.STP C.OUT/2.STP C.OUT/3.STP		
		E.Fb 3.STP	Three-step output with external feedback	C.OUT/3.STP		
		PP 2.STP i.PP 3.STP	On/off output with PPM Three-step output with internal feedback and PPM	C.OUT/2.STP C.OUT/3.STP		
		E.PP 3.STP	Three-step output with external feedback and PPM	C.OUT/3.STP		
		B.OUT Binary output BO1		oFF B.BO1 F01 B.BO1 F02 B.BO1 F03 B.BO1	OFF Active when binary input is set Active when WE is active Active in automatic mode	noPA B.OUT/B.BO1
				oFF B.BO2 F01 B.BO2 F02 B.BO2 F03 B.BO2	OFF Active when binary input is set Active when WE is active Active in automatic mode	noPA B.OUT1/B.BO2

¹⁾ Default setting is in **bold** print.

.....  ↓ or  →  ↓ and  , followed by  ↵



Parameter selection	Parameter name	Value range ¹⁾
No parameters		
CA.K1	Constant 1	[0.0 ... 100.0 %]
CA.K2	Constant 2	[0.0 ... 1.0 ... 10.0]
CA.K3	Constant 3	[-10.0 ... 0.0 ... +110.0 %]
KPL1	Gain Y+ (BO1)	[0.1 ... 1.0 ... 100.0]
KPL2	Gain Y- (BO2)	[0.1 ... 1.0 ... 100.0]
TYL1	Cycle duration Y+ (BO1)	[1.0 ... 10.0 ... 9999 s]
TYL2	Cycle duration Y- (BO2)	[1.0 ... 10.0 ... 9999 s]
▼ TYL1	Min. duty cycle Y+ (BO1)	[0.1 ... 1.0 s ... TYL1]
▼ TYL2	Min. duty cycle Y- (BO2)	[0.1 ... 1.0 s ... TYL2]
XSDY	Hysteresis	[0.10 ... 0.50 % ... TZ]
Surcharge	Dead band	[XSDY ... 2.00 ... 100 %]
TY	Transit time	[1 ... 60 ... 9999 s]
No parameter		
No parameter		





















¹⁾ Default setting is in **bold** print.

Annex A (configuration guide)

Menu	Function -CO-	Setting options ¹⁾	Description of functions	Parameter level -PA-
Limit relay				
ALRM LIM1	Limit relay L1	oFF L1	OFF	
		Lo L1.X	When X is not reached	
		Hi L1.X	When X is exceeded	LIM1/L1.X
		Lo L1.WE	When WE is not reached	LIM1/L1.X
		Hi L1.WE	When WE is exceeded	LIM1/L1.WE
		Lo L1.YP	When YPID is not reached	LIM1/L1.WE
		Hi L1.YP	When YPID is exceeded	LIM1/L1.YP
		Lo L1.XD	When XD is not reached	LIM1/L1.YP
		Hi L1.XD	When XD is exceeded	LIM1/L1.XD
		AbS L1.XD	When absolute value of XD is exceeded	LIM1/L1.XD
LIM2	Limit relay L2	oFF L2	OFF	
		Lo L2.X	When X is not reached	
		Hi L2.X	When X is exceeded	LIM2/L2.X
		Lo L2.WE	When WE is not reached	LIM2/L2.X
		Hi L2.WE	When WE is exceeded	LIM2/L2.WE
		Lo L2.YP	When YPID is not reached	LIM2/L2.WE
		Hi L2.YP	When YPID is exceeded	LIM2/L2.YP
		Lo L2.XD	When XD is not reached	LIM2/L2.YP
		Hi L2.XD	When XD is exceeded	LIM2/L2.XD
		AbS L2.XD	When absolute value of XD is exceeded	LIM2/L2.XD

¹⁾ Default setting is in **bold** print.

.....  ↓ or  →  ↓ and  , followed by  ←

Parameter selection	Parameter name	Value range ¹⁾
LI.X	Limit for X	[ IN1 ... 100.0 ...  IN1] ^{2,3} [ IN2 ... 100.0 ...  IN2] ^{2,3}
LI.WE	Limit for WE	[ IN1 ... 100.0 ...  IN1] ^{2,3} [ IN2 ... 100.0 ...  IN2] ^{2,3}
LI.YP	Limit for YPID	[ Y ... 100.0 % ...  Y]
LI.XD	Limit for XD	[-110.0 ... 0.0 ... +110.0 %]
LI.HYS	Hysteresis	[0.10 ... 0.50 ... 100.0 %]
LI.X	Limit for X	[ IN1 ... 100.0 ...  IN1] ^{2,3} [ IN2 ... 100.0 ...  IN2] ^{2,3}
LI.WE	Limit for WE	[ IN1 ... 100.0 ...  IN1] ^{2,3} [ IN2 ... 100.0 ...  IN2] ^{2,3}
LI.YP	Limit for YPID	[ Y ... 100.0 % ...  Y]
LI.XD	Limit for XD	[-110.0 ... 0.0 ... +110.0 %]
LI.HYS	Hysteresis	[0.10 ... 0.50 ... 100.0 %]

¹⁾ Default setting is in **bold print**.

²⁾ Decimal place depends on DP function (AUX menu)

³⁾ Value range identical to that of assigned input

Annex A (configuration guide)

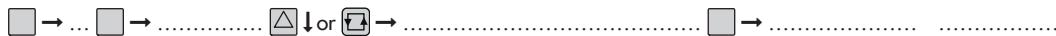

Menu	Function -CO-	Setting options ¹⁾	Description of functions	Parameter level -PA-
Alarm functions				
AUX	RE.CO Restart conditions after power failure	F01 MODE	Manual, with constant output value Y1K1	RE.CO/MODE
		F02 MODE	Auto, start with constant output value Y1K1	RE.CO/MODE
ST.IN Reset to default settings		FrEE INIT	OFF/completed	noPA ST.IN/INIT
		All INIT	All functions, parameters and code number	
		FUnC INIT	All functions	
		PARA INIT	All parameters and code number	
		AdJ INIT	Calibration values for IN1, IN2, Y	
KEYL Lock control keys		oFF LOCK	OFF	noPA KEYL/LOCK
		bi1 LOCK	Switched ON/OFF by binary input BI1	
		on noH.W	Selector, manual/automatic and cursor keys OFF	
VIEW Top/bottom viewing angle of display		01 VIEW	Level 1	noPA
		
		06 VIEW	Level 6	
		
		10 VIEW	Level 10	
FREQ Power line frequency		on 50Hz	50 Hz	noPA FREQ
		on 60Hz	60 Hz	
DP Decimal separator		on DP0	No digit	noPA DP1
		on DP1	One digit	
		on DP2	Two digits	

¹⁾ Default setting is in **bold** print.

.....  ↓ or  →  ↓ and  , followed by  ←

Parameter selection	Parameter name	Value range ¹⁾
Y1K1	Constant output value	[-10.0 ... 0.0 ... +110.0 %]

No parameters

No parameters

No parameters

No parameter





No parameters

¹⁾ Default setting is in **bold** print.

Annex A (configuration guide)

Menu	Function -CO-	Setting options ¹⁾	Description of functions	Parameter level -PA-
Start-up adaptation				
TUNE	ADAP Adaptation	oFF ADP.S run ADP.S	OFF Start	ADAP/ADP.S
Process data				
I-O	CIN Firmware version		Reading	
	S-No Serial number		Reading	
	ANA Show analog inputs and outputs	IN1 IN2 CO.VA WE.VA FE.CO SP.CO YPID YOUT	Analog input IN1 Analog input IN2 Controlled variable before function generation WE before function generation WE after function generation Set point at comparator YPID after limitation Analog output	
	BIN Show binary inputs and outputs	BI1 BO1 BO2	Binary input BI Binary output BO1 Binary output BO2	
	ADJ Calibration	AdJ IN1 AdJ IN2 AdJ YOUT	Analog input IN1 Analog input IN2 Analog output	

¹⁾ Default setting is in **bold** print.

.....  ↓ or  →  ↓ and  , followed by  ←

Parameter selection	Parameter name	Value range ¹⁾
KP	Proportional-action coefficient	[0.1 ... 1.0 ... 100.0]
TN	Reset time	[1 ... 120 ... 9999 s]
TV	Derivative-action time	[1 ... 10 ... 9999 s]
Y.JMP	Step-change value for adaptation	[-100.0 ... +20.0 ... +100.0 %]

¹⁾ Default setting is in **bold** print.

17.3 Configuration protocol

Menu	Function -CO-	Parameters -PA-	
PAR		KP: (see -CO- C.PID)	
		TN: (see -CO- C.PID)	
		TV: (see -CO- C.PID)	
		Y.PRE: (see -CO- C.PID)	
IN	IN1:	↘ IN1:	
		↗ IN1:	
	IN2:	↘ IN2:	
		↗ IN2:	
	MEAS:	No parameters	
	MAN:	Y1K1: (see -CO- SAFE and -CO- RE.CO)	
	CLAS	X:	No parameters
		WE:	No parameters
	DI.FI	X:	TS.X:
		WE:	TS.WE:
	SQR	X:	No parameters
		WE:	No parameters
	FUNC	X:	MIN:
			MAX:
			K1.X:
			K1.Y:
			K2.X:
			K2.Y:
			K3.X:
			K3.Y:
K4.X:			
K4.Y:			
K5.X:			
K5.Y:			

Menu	Function -CO-	Parameters -PA-	
IN	FUNC	X:	K6.X:
			K6.Y:
			K7.X:
			K7.Y:
		WE:	MIN:
			MAX:
			K1.X:
			K1.Y:
			K2.X:
			K2.Y:
			K3.X:
			K3.Y:
			K4.X:
			K4.Y:
			K5.X:
			K5.Y:
			K6.X:
			K6.Y:
			K7.X:
			K7.Y:
SETP	SP.VA	W:	W:
			↘ WINT:
			↗ WINT:
			↘ WRAN:
		↗ WRAN:	
		W2:	W2:
		WE:	No parameters
	SP.FU	RAMP:	TSRA:
			WIRA:
		CH.SP:	No parameters

Annex A (configuration guide)

Menu	Function -CO-	Parameters -PA-
CNTR	C.PID:	KP: (see PAR)
		TN: (see PAR)
		TV: (see PAR)
		TVK1:
		TV: (see PAR)
		DZXD:
		↘ DZXD:
		↗ DZXD:
	SIGN:	No parameters
	D.PID:	No parameters
	CH.CA:	CLI.P:
		CLI.M:
	M.ADJ:	No parameters
	DIRE:	No parameters
	F.FOR:	FC.K1:
FC.K2:		
FC.K3:		
AC.VA:	AV.K1:	
OUT	SAFE:	Y1K1: (see -CO- MAN and -CO- RE.CO)
	MA.AU	No parameters
	Y.LIM	↘ Y:
		↗ Y:
	RAMP:	TSRA:
		Y1RA:
	BLOC:	No parameters
	FUNC:	K1.X:
		K1.Y:
		K2.X:
K2.Y:		
K3.X:		

Menu	Function -CO-	Parameters -PA-
OUT	FUNC:	K3.Y:
		K4.X:
		K4.Y:
		K5.X:
		K5.Y:
		K6.X:
		K6.Y:
		K7.X:
	K7.Y:	
	Y.VA:	No parameters
	Y.SRC:	No parameters
	CALC:	CA.K1:
		CA.K2:
		CA.K3:
	C.OUT:	KPL1:
		KPL2:
		TYL1:
		TYL2:
		↘ TYL1:
		↗ TYL2:
		XSDY:
TZ:		
TY:		
B.OUT	B.OUT1:	No parameters
	B.OUT2:	No parameters
ALRM	LIM1:	LI.X:
		LI.WE:
		LI.YP:
		LI.XD:
		LI.HYS:

Annex A (configuration guide)

Menu	Function -CO-	Parameters -PA-
ALRM	LIM2:	LI.X:
		LI.WE:
		LI.YP:
		LI.XD:
		LI.HYS:
AUX	RE.CO:	Y1K1: (see -CO- MAN and -CO- SAFE)
	ST.IN:	No parameters
	KEYL:	No parameters
	VIEW:	No parameters
	FREQ:	No parameters
	DP:	No parameters
TUNE	TUNE:	KP:
		TN:
		TV:
		Y.JMP:

18 Annex B

18.1 Accessories

Infrared adapter (RS-232)	Order no. 8864-0900
Fixture for infrared adapter	Order no. 1400-9769
USB to RS-232 adapter	Order no. 8812-2001
Driver for USB to RS-232 adapter	▶ www.samsongroup.com > Service & Support > Download > TROVIS-VIEW > USB/RS-232 adapter (8812-2001)
TROVIS-VIEW software (free of charge)	▶ www.samsongroup.com > SERVICE & SUPPORT > Downloads > TROVIS-VIEW

18.2 After-sales service

Consultation and questions

Contact SAMSON's After-sales Service for support concerning service or repair work or when malfunctions or errors arise.

E-mail contact

You can reach our after-sales service at aftersalesservice@samsongroup.com.

Addresses of SAMSON AG and its subsidiaries

The addresses of SAMSON, its subsidiaries, representatives and service facilities worldwide can be found on our website (▶ www.samsongroup.com) or in all SAMSON product catalogs.

Required specifications

Please submit the following details:

- Model number
- Configuration ID
- Serial number
- Firmware version

EB 6493 EN



SAMSON AKTIENGESELLSCHAFT

Weismüllerstraße 3 · 60314 Frankfurt am Main, Germany

Phone: +49 69 4009-0 · Fax: +49 69 4009-1507

samson@samsongroup.com · www.samsongroup.com