

MOUNTING AND OPERATING INSTRUCTIONS



EB 5840 EN

Translation of original instructions



Type 2780-1 and Type 2780-2 Pneumatic Actuators

Actuator area: 120 cm²

Edition November 2023

Note on these mounting and operating instructions

These mounting and operating instructions assist you in mounting and operating the device safely. The instructions are binding for handling SAMSON devices. The images shown in these instructions are for illustration purposes only. The actual product may vary.

- For the safe and proper use of these instructions, read them carefully and keep them for later reference.
- If you have any questions about these instructions, contact SAMSON's After-sales Service (aftersaleservice@samsongroup.com).



Documents relating to the device, such as the mounting and operating instructions, are available on our website at www.samsongroup.com > **Downloads > Documentation.**

Definition of signal words

DANGER

Hazardous situations which, if not avoided, will result in death or serious injury

WARNING

Hazardous situations which, if not avoided, could result in death or serious injury

NOTICE

Property damage message or malfunction

Note

Additional information

Tip

Recommended action

1	Safety instructions and measures	1-1
1.1	Notes on possible severe personal injury	1-4
1.2	Notes on possible personal injury	1-4
1.3	Notes on possible property damage	1-6
1.4	Warnings on the device	1-6
2	Markings on the device	2-1
2.1	Actuator nameplate	2-1
3	Design and principle of operation	3-1
3.1	Direction of action	3-1
3.2	Signal pressure routing	3-1
3.3	Fail-safe action	3-3
3.3.1	Actuator stem extends	3-3
3.3.2	Actuator stem retracts	3-4
3.4	Accessories	3-4
3.5	Technical data	3-4
4	Shipment and on-site transport	4-1
4.1	Accepting the delivered goods	4-1
4.2	Removing the packaging from the actuator	4-1
4.3	Transporting and lifting the actuator	4-1
4.3.1	Transporting the actuator	4-1
4.3.2	Lifting the actuator	4-2
4.4	Storing the actuator	4-2
5	Installation	5-1
5.1	Preparation for installation	5-1
5.2	Mounting the device	5-1
5.2.1	Mounting the actuator onto the valve	5-2
5.2.2	Pneumatic connection	5-2
6	Operation	6-1
6.1	Supply pressure in closed-loop operation	6-2
7	Malfunctions	7-1
7.1	Troubleshooting	7-1
7.2	Emergency action	7-2

Contents

8	Servicing and conversion	8-1
8.1	Periodic testing	8-2
8.2	Preparation for servicing or conversion work.....	8-3
8.3	Mounting the actuator on the valve after service or conversion work	8-3
8.4	Service work.....	8-3
8.4.1	Replacing the diaphragm	8-3
8.5	Conversion work.....	8-5
8.5.1	Reversing the direction of action (fail-safe action)	8-5
8.6	Ordering spare parts and operating supplies	8-6
9	Decommissioning	9-1
10	Removal	10-1
10.1	Removing the actuator from the valve	10-2
10.2	Relieving the spring compression in the actuator.....	10-2
11	Repairs	11-1
11.1	Returning devices to SAMSON	11-1
12	Disposal	12-1
13	Certificates	13-1
14	Annex	14-1
14.1	Tightening torques, lubricants and tools	14-1
14.2	Spare parts	14-1
14.3	After-sales service	14-4

1 Safety instructions and measures

Intended use

The SAMSON Type 2780 Actuator is designed for operating a mounted globe valve. In combination with the valve, the actuator is used to shut off the flow of liquids, gases or vapors in the pipeline. The actuator is suitable for throttling service and can be used in HVAC plants.

The actuator is designed to operate under exactly defined conditions (e.g. thrust, travel). Therefore, operators must ensure that the actuator is only used in operating conditions that meet the specifications used for sizing the actuator at the ordering stage. In case operators intend to use the actuator in applications or conditions other than those specified, contact SAMSON.

SAMSON does not assume any liability for damage resulting from the failure to use the device for its intended purpose or for damage caused by external forces or any other external factors.

→ Refer to the technical data and nameplate for limits and fields of application as well as possible uses.

Reasonably foreseeable misuse

The actuator is not suitable for the following applications:

- Use outside the limits defined during sizing and by the technical data
- Use outside the limits defined by the accessories connected to the actuator

Furthermore, the following activities do not comply with the intended use:

- Use of non-original spare parts
- Performing service and repair work not described

Qualifications of operating personnel

The actuator must be mounted, started up, serviced and repaired by fully trained and qualified personnel only; the accepted industry codes and practices must be observed. According to these mounting and operating instructions, trained personnel refers to individuals who are able to judge the work they are assigned to and recognize possible hazards due to their specialized training, their knowledge and experience as well as their knowledge of the applicable standards.

Safety instructions and measures

Personal protective equipment

We recommend wearing the following personal protective equipment when handling the Type 2780 Pneumatic Actuator:

- Protective gloves and safety footwear when mounting or removing the actuator
 - Eye protection and hearing protection while the actuator is operating.
- ➔ Check with the plant operator for details on further protective equipment.

Revisions and other modifications

Revisions, conversions or other modifications of the product are not authorized by SAMSON. They are performed at the user's own risk and may lead to safety hazards, for example. Furthermore, the product may no longer meet the requirements for its intended use.

Safety devices

The Type 2780 Actuator does not have any special safety features.

Warning against residual hazards

To avoid personal injury or property damage, plant operators and operating personnel must prevent hazards that could be caused in the actuator by the signal pressure, stored spring energy or moving parts by taking appropriate precautions. Plant operators and operating personnel must observe all hazard statements, warnings and caution notes in these mounting and operating instructions.

Responsibilities of the operator

Operators are responsible for proper use and compliance with the safety regulations. Operators are obliged to provide these mounting and operating instructions as well as the referenced documents to the operating personnel and to instruct them in proper operation. Furthermore, operators must ensure that operating personnel or third parties are not exposed to any danger.

Responsibilities of operating personnel

Operating personnel must read and understand these mounting and operating instructions as well as the referenced documents and observe the specified hazard statements, warnings and caution notes. Furthermore, operating personnel must be familiar with the applicable health, safety and accident prevention regulations and comply with them.

Referenced standards, directives and regulations

According to the ignition hazard assessment performed in accordance with Clause 5.2 of ISO 80079-36, the non-electrical actuators do not have their own potential ignition source even in the rare incident of an operating fault. As a result, they do not fall within the scope of Directive 2014/34/EU.

→ For connection to the equipotential bonding system, observe the requirements specified in Clause 6.4 of EN 60079-14 (VDE 0165-1).

The Type 2780-1 and Type 2780-2 Actuators are partly completed machinery as defined in the Machinery Directive 2006/42/EC.

Referenced documentation

The following documents apply in addition to these mounting and operating instructions:

- Mounting and operating instructions for the valve on which it is mounted
- Mounting and operating instructions for mounted valve accessories (positioner, solenoid valve etc.)
- ► AB 0100 for tools, tightening torques and lubricant

1.1 Notes on possible severe personal injury

DANGER

Risk of bursting in the actuator.

Actuators are pressurized. Improper opening can lead to actuator components bursting.

- Before starting any work on the actuator, depressurize all plant sections affected and the actuator.

1.2 Notes on possible personal injury

WARNING

Crush hazard arising from moving parts.

The actuator contains moving parts (actuator stem), which can injure hands or fingers if inserted into the actuator.

- Do not touch the actuator stem or insert hands or finger into the yoke or beneath the actuator stem while the air supply is connected to the actuator.
- While working on the actuator, disconnect and lock the pneumatic air supply as well as the control signal.
- Do not impede the movement of the actuator stem by inserting objects into the yoke.
- Before unblocking the actuator stem after it has become blocked (e.g. due to seizing up after remaining in the same position for a long time), release any stored energy in the actuator (e.g. spring compression). See 'Relieving the spring compression in the actuator' in the 'Removal' section.

¹⁾ If not described otherwise in the valve documentation, the work position for the control valve is the front view looking onto the operating controls (including valve accessories).

⚠ WARNING**Risk of personal injury when the actuator vents.**

The actuator is operated with air. As a result, air is vented during operation.

- Install the control valve in such a way that vent openings are not located at eye level and the actuator does not vent at eye level in the work position ¹⁾.
- Use suitable mufflers and vent plugs.
- Wear eye and hearing protection when working near the actuator.

Risk of personal injury due to preloaded springs.

Actuators with preloaded springs are under tension. These actuators are marked accordingly by an adhesive label. Additionally, they can be identified by the longer bolts with nuts protruding from the bottom diaphragm case. These bolts allow the spring compression to be relieved evenly on disassembling the actuator.

- Before starting any work on the actuator, relieve the compression from the preloaded springs. See 'Relieving the spring compression in the actuator' in the 'Removal' section.

Risk of personal injury due to incorrect operation, use or installation as a result of information on the actuator being illegible.

Over time, markings, labels and nameplates on the actuator may become covered with dirt or become illegible in some other way. As a result, hazards may go unnoticed and the necessary instructions not followed. There is a risk of personal injury.

- Keep all relevant markings and inscriptions on the device in a constantly legible state.
- Immediately renew damaged, missing or incorrect nameplates or labels.

1.3 Notes on possible property damage

! NOTICE

Risk of actuator damage due to excessively high or low tightening torques.

Observe the specified torques when tightening actuator components. Excessive tightening torques lead to parts wearing out more quickly. Parts that are not tightened far enough may loosen.

→ Observe the specified tightening torques (▶ AB 0100).

Risk of actuator damage due to the use of unsuitable tools.

Certain tools are required to work on the actuator.

→ Only use tools approved by SAMSON (▶ AB 0100).

Risk of actuator damage due to the use of unsuitable lubricants.

The lubricants to be used depend on the actuator material. Unsuitable lubricants may corrode and damage surfaces.

→ Only use lubricants approved by SAMSON (▶ AB 0100).

1.4 Warnings on the device

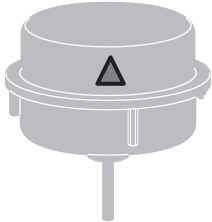

Warning symbols	Meaning of the warning	Location on the device
	<p>Warning to indicate that the springs in the actuator are preloaded.</p> <p>Actuators with preloaded springs are under tension. Incorrect opening of the actuator can lead to personal injury due to the sudden and uncontrolled projection of parts.</p> <p>Before starting any work on the actuator, relieve the compression from the preloaded springs. See 'Relieving the spring compression in the actuator' in the 'Removal' section.</p>	

2 Markings on the device

The nameplate shown was up to date at the time of publication of this document. The nameplate on the device may differ from the one shown.

2.1 Actuator nameplate

The nameplate is stuck to the diaphragm casing. It includes all details required to identify the device:

Item	Inscription meaning
2	Type designation
3	Company name
4	Company address (ZIP/postal code and city)
5	Data Matrix code
6	Device designation
9	Serial number
10	Material no.
12	Country of origin
13	Month and year of manufacture
15	Symbol indicating fail-safe action:  Actuator stem extends (FA)  Actuator stem retracts (FE)
16	Actuator area in cm ²
18	Bench range in bar
19	Bench range in psi
20	Actuator travel in mm

Item	Inscription meaning
24	Permissible operating pressure p_{max} in bar and/or psi
25	Diaphragm material
28	Symbol for manual override:  (optional)
33	ID of the notified body (EU), for example: – 0062 for Bureau Veritas Services SAS, 8 Cours du Triangle, 92800 PUTEAUX – LA DEFENSE
34	Model number
35	Input signal in mA
36	Degree of protection
40	Other certification (optional)

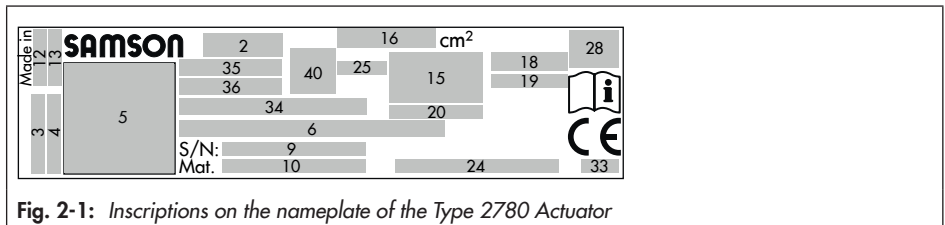

Fig. 2-1: Inscriptions on the nameplate of the Type 2780 Actuator

3 Design and principle of operation

The pneumatic actuators are used especially for attachment to Type 3222 and Type 3213 Valves. In this case, force-locking attachment is used.

The actuators mainly consist of two diaphragm cases, the actuator stem (A2/A5), rolling diaphragm (A48) and springs (A25-29). The housings have an actuator area of 120 cm² and are made of die-cast aluminum.

The signal pressure creates a force at the diaphragm surface, which is opposed by the springs in the actuator. The direction of action of the actuator stem depends on how the springs are installed in the actuator. The springs may be fitted into one another.

The Type 2780-2 Actuator is designed for the direct attachment of a positioner as standard. A yoke is located on the bottom diaphragm case for attachment of a pneumatic or electropneumatic positioner.

3.1 Direction of action

The direction of action is determined by how the springs and diaphragm plate are arranged in the actuator.

With direction of action "actuator stem extends", the compressed air is applied to the signal pressure connection on the bottom diaphragm case.

With direction of action "actuator stem retracts", the compressed air is applied to the

signal pressure connection on the top diaphragm case.

The actuator's direction of action can be reversed (see the 'Operation' section).

3.2 Signal pressure routing

Type 2780-1x (see Fig. 3-1)

In the "actuator stem extends" version, the signal pressure is routed through the bottom signal pressure connection (S_{FA}) to the bottom diaphragm chamber. In the "actuator stem retracts" version, the signal pressure is routed through the top signal pressure connection (S_{FE}) to the top diaphragm chamber.

Type 2780-2x (see Fig. 3-2 and Fig. 3-3)

In the Type 2780-2 Actuator, the signal pressure is transmitted to the diaphragm chamber through the holes (S_{FA} , S_{FE}) on the left or right side of the yoke and over a **switchover plate**. The fail-safe action of the actuator ("actuator stem extends" or "actuator stem retracts") determines how the positioner must be attached and the switchover plate must be aligned.

The switchover plate needs to be turned to align the correct symbol for the fail-safe action with the marking. The attachment either on the left or right side of the actuator is determined by the required direction of action of the positioner (>> or <>).

If the actuator is operated without a positioner, a **connecting plate** is required instead of the switchover plate. In this case, the signal pressure is routed directly over the signal

Design and principle of operation

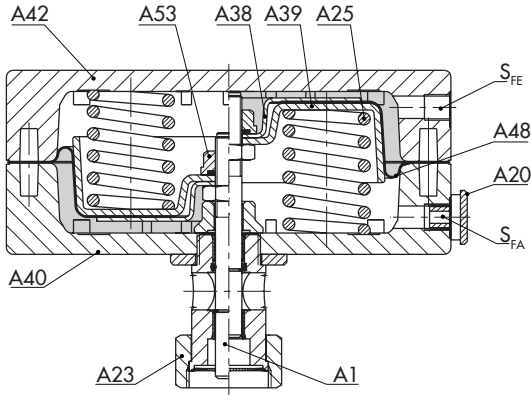
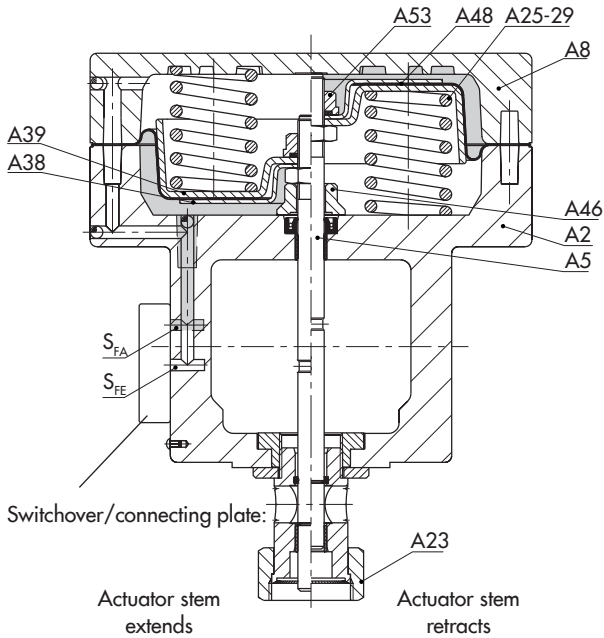

Fig. 3-1: Type 2780-1

Actuator stem extends

Actuator stem retracts



- A1 Actuator stem
- A2 Lower actuator section
- A5 Actuator stem
- A8 Diaphragm case
- A20 Vent plug
- A23 Coupling nut
- A25-29 Compression spring
- A38 Metal plate
- A39 Diaphragm plate
- A40 Bottom diaphragm case
- A42 Top diaphragm case
- A46 Stop bushing
- A48 Diaphragm
- A53 Collar nut
- S_{FA} Signal pressure connection (actuator stem extends)
- S_{FE} Signal pressure connection (actuator stem retracts)

Fig. 3-2: Type 2780-2

pressure connection of the connecting plate to the actuator diaphragm chamber.

The connecting plate needs to be turned to align the correct symbol for the fail-safe action with the marking.

i Note

The listed fail-safe actions apply to SAMSON globe valves.

3.3 Fail-safe action

When the signal pressure is reduced or the control signal fails, the fail-safe position of the control valve depends on whether the springs are installed in the top or bottom diaphragm chamber.

3.3.1 Actuator stem extends

When the signal pressure is reduced or the control signal fails, the springs move the actuator stem downward and close the globe valve. The valve opens when the signal pressure is increased enough to overcome the spring force.

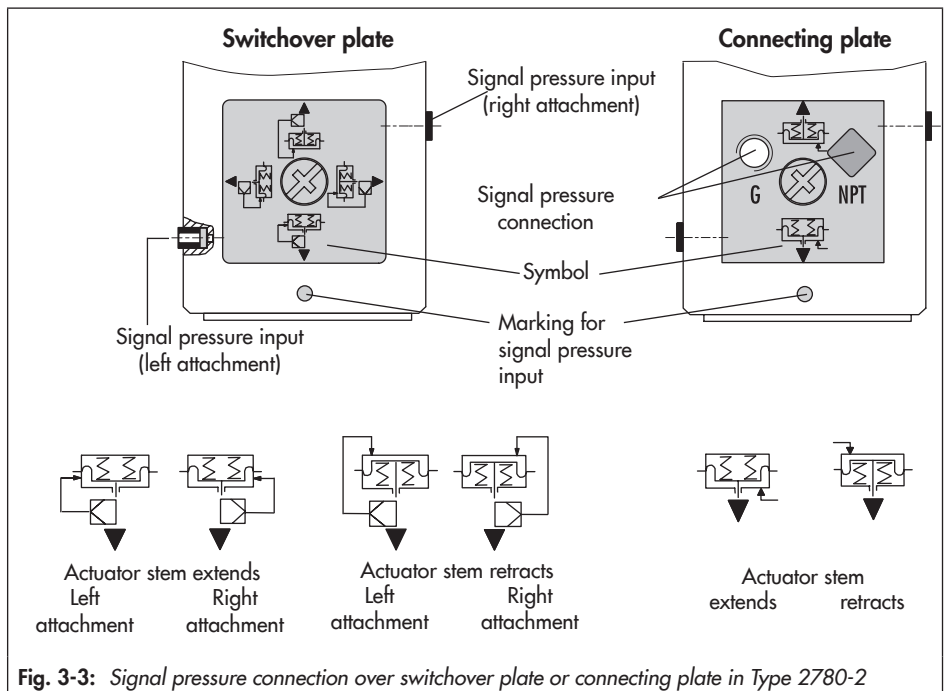

Fig. 3-3: Signal pressure connection over switchover plate or connecting plate in Type 2780-2

Design and principle of operation

3.3.2 Actuator stem retracts

When the signal pressure is reduced or the control signal fails, the springs move the actuator stem upward and open a mounted globe valve. The valve closes when the signal pressure is increased enough to overcome the spring force.

3.4 Accessories

Switchover plate/connecting plate

Switchover plates and connecting plates are listed as accessories.

		With index	Order no.
Switchover plate	New	.01	1400-6822
	Old	.00	1400-6819
Connecting plate	New	.01	1400-6823
	G thread	.00	1400-6820
	NPT thread	.00	1400-6821

i Note

Actuators with device index .01 are equipped with new connecting plates. Old and new connecting plates are not interchangeable.

Vent plugs

Vent plugs are screwed into the exhaust air ports of pneumatic and electropneumatic devices. They ensure that any exhaust air that forms can be vented to the atmosphere (to avoid excess pressure in the device). Furthermore, the vent plugs allow air intake to prevent a vacuum from forming in the device.

Lifting fixture

A special lifting tool is available to lift pneumatic actuators with 120 cm² actuator area (▶ AB 0100).

3.5 Technical data

The nameplate provides information on the actuator version (see the 'Markings on the device' section).

i Note

More information is available in Data Sheet ▶ T 5840.

Temperature range

The permissible ambient temperature for NBR diaphragm material is -35 to +80 °C.

Supply pressure

The maximum permissible supply pressure is 4 bar in throttling service.

Dimensions

Dimensions (see Fig. 3-4)

Weights

Version	Weight
Type 2780-1	2 kg
Type 2780-2	3.2 kg

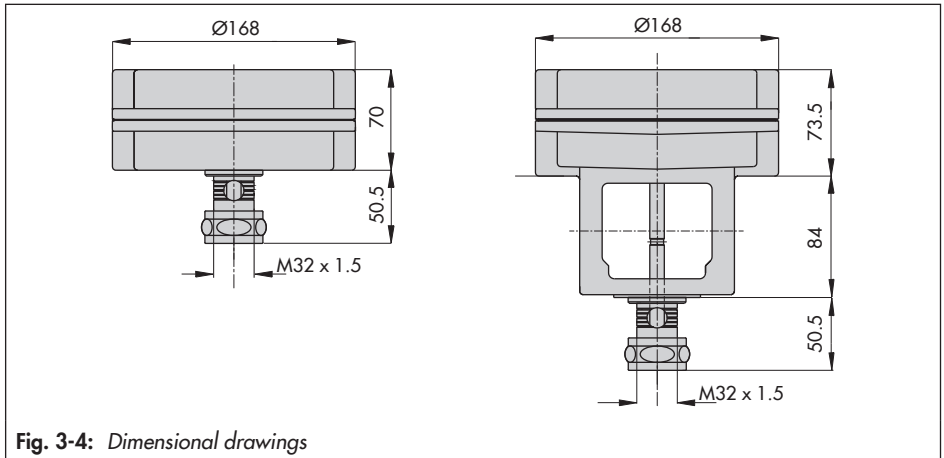

Fig. 3-4: Dimensional drawings

4 Shipment and on-site transport

The work described in this section is only to be performed by personnel appropriately qualified to carry out such tasks.

4.1 Accepting the delivered goods

After receiving the shipment, proceed as follows:

1. Check the scope of delivery. Check that the specifications on the actuator nameplate match the specifications in the delivery note. See the 'Markings on the device' section for nameplate details.
2. Check the shipment for transportation damage. Report any damage to SAMSON and the forwarding agent (refer to delivery note).
3. Determine the weight and dimensions of the units to be lifted and transported in order to select the appropriate lifting equipment and lifting accessories. Refer to the transport documents and the 'Technical data' section.

4.2 Removing the packaging from the actuator

Observe the following sequence:

- Do not open or remove the packaging until immediately before mounting the actuator.
- Dispose and recycle the packaging in accordance with the local regulations.

4.3 Transporting and lifting the actuator

DANGER

Danger due to suspended loads falling.

- Stay clear of suspended or moving loads.
- Close off and secure the transport paths.

WARNING

Risk of lifting equipment tipping over and risk of damage to lifting accessories due to exceeding the rated lifting capacity.

- Only use approved lifting equipment and accessories whose minimum lifting capacity is higher than the weight of the actuator (including the packaging, if applicable).

Tip

Our after-sales service can provide more detailed transport and lifting instructions on request.

4.3.1 Transporting the actuator

- Leave the actuator in its packaging to transport it.
- Observe the transport instructions.

Transport instructions

- Protect the actuator against external influences (e.g. impact).

Shipment and on-site transport

- Do not damage the corrosion protection (paint, surface coatings). Repair any damage immediately.
- Protect the actuator against moisture and dirt.
- Observe permissible temperatures (see 'Technical data' in the 'Design and principle of operation' section).

4.3.2 Lifting the actuator

Due to the low service weight, lifting equipment is not required to lift the actuator (e.g. to mount it onto a valve). If lifting equipment (e.g. crane or forklift) is to be used, we have a gripping device available for the actuator (see 'Accessories' in the 'Design and principle of operation' section).

i Note

See valve documentation for more information on lifting the entire control valve assembly.

Lifting instructions using lifting equipment

- Use a hook with safety latch to secure the slings from slipping off the hook during lifting and transporting.
- Secure slings on the object to be transported against slipping.
- Make sure the slings can be removed from the actuator once it has been mounted on the valve.
- Prevent the actuator from tilting or tipping.

- Do not leave loads suspended when interrupting work for longer periods of time.

4.4 Storing the actuator

! NOTICE

Risk of actuator damage due to improper storage.

- Observe the storage instructions.
 - Avoid long storage times.
 - Contact SAMSON in case of different storage conditions or longer storage times.
-

i Note

We recommend regularly checking the actuator and the prevailing storage conditions during long storage times.

Storage instructions

- When the valve and actuator are already assembled, observe the storage conditions for control valves. See associated valve documentation.
- Protect the actuator against external influences (e.g. impact).
- Secure the actuator in the stored position against slipping or tipping over.
- Do not damage the corrosion protection (paint, surface coatings). Repair any damage immediately.
- Protect the actuator against moisture and dirt. Store it at a relative humidity of less than 75 %. In damp spaces, prevent con-

densation. If necessary, use a drying agent or heating.

- Make sure that the ambient air is free of acids or other corrosive media.
- Observe permissible temperatures (see 'Technical data' in the 'Design and principle of operation' section).
- Do not place any objects on the actuator.

Special storage instructions for elastomers

Elastomer, e.g. actuator diaphragm

- To keep elastomers in shape and to prevent cracking, do not bend them or hang them up.
- We recommend a storage temperature of 15 °C for elastomers.
- Store elastomers away from lubricants, chemicals, solutions and fuels.



Tip

Our after-sales service can provide more detailed storage instructions on request.

5 Installation

The work described in this section is only to be performed by personnel appropriately qualified to carry out such tasks.

5.1 Preparation for installation

Before mounting, make sure the following conditions are met:

- The actuator is not damaged.
- The type designation, material and temperature range of the actuator match the ambient conditions (temperatures etc.). See the 'Markings on the device' section for nameplate details.

Proceed as follows:

- ➔ Lay out the necessary material and tools to have them ready during mounting.
- ➔ Check that the vent plugs to be used are not blocked.
- ➔ Check any pressure gauges mounted on valve accessories to make sure they function properly.
- ➔ When the valve and actuator are already assembled, check the tightening torques of the bolted joints (▶ AB 0100). Components may loosen during transport.

5.2 Mounting the device

Depending on the version, SAMSON control valves are either delivered with the actuator already mounted on the valve or the valve and actuator are delivered separately. When delivered separately, the valve and actuator

must be assembled together on site. Proceed as follows to mount the actuator and before start-up.

⚠ WARNING

Risk of personal injury due to exhaust air being vented.

The actuator is operated with air. As a result, air is vented during operation.

- ➔ *During mounting make sure that vent openings are not located at eye level in the work position of the control valve and the actuator does not vent at eye level in the work position.*
 - ➔ *Wear eye and hearing protection when working near the actuator.*
-

⚠ WARNING

Crush hazard arising from the moving actuator stem.

- ➔ *Do not touch the actuator stem or insert hands or finger into the yoke while the air supply is connected to the actuator.*
 - ➔ *Before working on the actuator, disconnect and lock the pneumatic air supply as well as the control signal.*
 - ➔ *Do not impede the movement of the actuator stem by inserting objects into the yoke.*
 - ➔ *Before unblocking the actuator stem after it has become blocked (e.g. due to seizing up after remaining in the same position for a long time), release any stored energy in the actuator (e.g. spring compression). See 'Relieving the spring compression in the actuator' in the 'Removal' section.*
-

NOTICE

Risk of actuator damage due to excessively high or low tightening torques.

Observe the specified torques when tightening actuator components. Excessive tightening torques lead to parts wearing out more quickly. Parts that are not tightened far enough may loosen.

➔ Observe the specified tightening torques (▶ AB 0100).

NOTICE

Risk of actuator damage due to the use of unsuitable tools.

➔ Only use tools approved by SAMSON (▶ AB 0100).

5.2.1 Mounting the actuator onto the valve

See Fig. 5-1

Tip

The valve and actuator are assembled with special attention paid to the actuator's bench range and direction of action. These details are specified on the actuator nameplate (see the 'Markings on the device' section).

1. Loosen the nut (12) at the valve.
2. Firmly press the plug together with the plug stem into the seat ring.
3. Thread the nut (12) downward.

4. Remove the coupling nut (A23) at the actuator.
5. Slide the coupling nut (A23) over the plug stem (15).
6. Place the actuator on the valve. Fasten the actuator stem (A1) and plug stem (15) together using the coupling nut (A23). Observe tightening torques.

5.2.2 Pneumatic connection

The maximum permissible supply pressure is 4 bar in throttling service.

How and with which accessories the air supply is connected depends on the actuator model and its direction of action. See 'Direction of action', 'Signal pressure routing' and 'Accessories' in the 'Design and principle of operation' section.

When using a connecting plate, make sure the following conditions are met:

- The gasket for the connecting plate is correctly inserted.
- The connecting plate has threaded holes with NPT and G threads. The signal pressure connection that is not used is sealed with the rubber seal and square plug.

a) Actuator stem extends

1. Apply a signal pressure that corresponds to the lower signal pressure range value to the connection on the bottom diaphragm case.

2. Screw the vent plug into the connection on the top diaphragm case.

b) Actuator stem retracts

1. Apply a signal pressure that corresponds to the upper signal pressure range value to the connection on the top diaphragm case.
2. Screw the vent plug into the connection on the bottom diaphragm case.

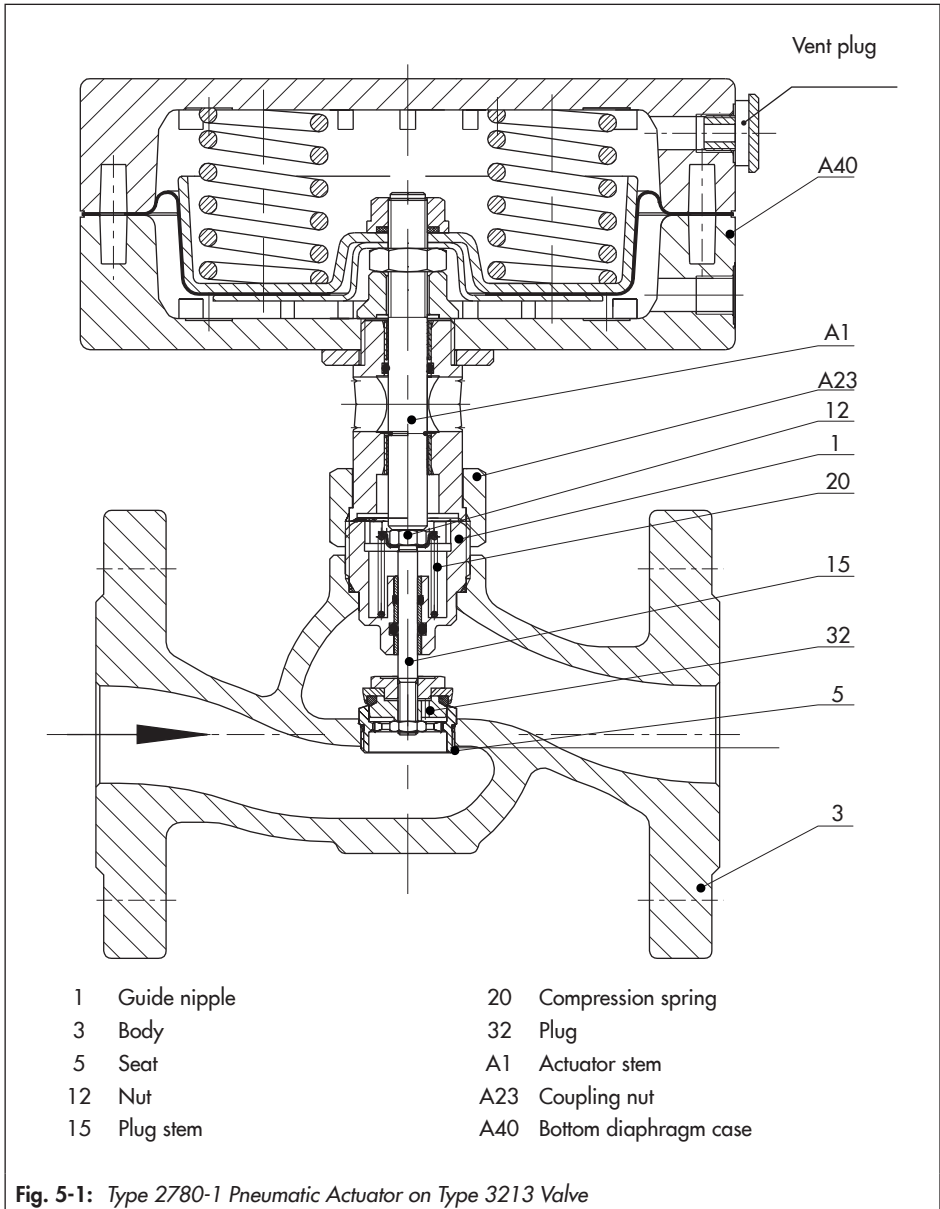

6 Operation

The work described in this section is only to be performed by personnel appropriately qualified to carry out such tasks.

⚠ DANGER

Risk of bursting due to incorrect opening of pressurized equipment or components.

Pneumatic actuators are pressure equipment that may burst when handled incorrectly.

Flying projectile fragments or components can cause serious injury or even death.

Before working on the actuator:

- Depressurize all plant sections concerned and the actuator. Release any stored energy.

⚠ WARNING

Risk of personal injury due to exhaust air being vented.

The actuator is operated with air. As a result, air is vented during operation.

- Wear eye and hearing protection when working near the actuator.

⚠ WARNING

Crush hazard arising from the moving actuator stem.

- Do not insert hands or finger into the yoke while the air supply is connected to the actuator.

- Before working on the actuator, disconnect and lock the pneumatic air supply as well as the control signal.
- Do not impede the movement of the actuator stem by inserting objects into the yoke.
- Before unblocking the actuator stem after it has become blocked (e.g. due to seizing up after remaining in the same position for a long time), release any stored energy in the actuator (e.g. spring compression). See 'Relieving the spring compression in the actuator' in the 'Removal' section.

⚠ WARNING

Risk of personal injury through incorrect operation, use or installation as a result of incorrect information on the actuator.

After any adjustment or conversion work, the details on the actuator nameplate may no longer be correct. This may apply, for example, to the configuration ID or the symbol after reversal of the direction of action.

- Immediately renew any nameplates or labels with incorrect or outdated information.
- Add any new values to the nameplate. If necessary, contact SAMSON to obtain a new nameplate.

6.1 Supply pressure in closed-loop operation

The Type 2780 Pneumatic Actuator is designed for a maximum supply pressure of 4 bar.

Only apply the signal pressure to the diaphragm chamber of the actuator that does not contain any springs. See the 'Design and principle of operation' section.

7 Malfunctions

Read hazard statements, warnings and caution notes in the 'Safety instructions and measures' section.

7.1 Troubleshooting

Malfunction	Possible reasons	Recommended action
Actuator stem does not move on demand.	Actuator is blocked.	Check attachment. Remove the blockage. WARNING! A blocked actuator (e.g. due to seizing up after remaining in the same position for a long time) can suddenly start to move uncontrollably. Injury to hands or fingers is possible if they are inserted into the actuator or valve. Before trying to unblock the actuator stem, disconnect and lock the pneumatic air supply as well as the control signal. Before unblocking the actuator stem, release any stored energy in the actuator (e.g. spring compression). See 'Relieving the spring compression in the actuator' in the 'Removal' section.
	Insufficient signal pressure	Check the signal pressure. Check the signal pressure line for leakage.
	Signal pressure not connected to the correct diaphragm chamber.	See 'Signal pressure routing' in the 'Design and principle of operation' section.
	Diaphragm in the actuator defective	See 'Replacing the diaphragm' in the 'Servicing' section.
Actuator stem does not stroke through its complete travel range.	Insufficient signal pressure	Check the signal pressure. Check the signal pressure line for leakage.
	Incorrect setting of valve accessories.	Check the actuator without valve accessories. Check the settings of the valve accessories.

i Note

Contact our after-sales service for malfunctions not listed in the table.

7.2 Emergency action

Plant operators are responsible for emergency action to be taken in the plant.

8 Servicing and conversion

The work described in this section is only to be performed by personnel appropriately qualified to carry out such tasks.

The following documents are also required for servicing the valve:

- ► AB 0100 for tools, tightening torques and lubricant

⚠ DANGER

Risk of bursting due to incorrect opening of pressurized equipment or components.

Pneumatic actuators are pressure equipment that may burst when handled incorrectly.

Flying projectile fragments or components can cause serious injury or even death.

Before working on the actuator:

- *Depressurize all plant sections concerned and the actuator. Release any stored energy.*

⚠ WARNING

Risk of personal injury due to preloaded springs.

Actuators with preloaded springs are under tension. These actuators are marked accordingly by an adhesive label. Additionally, they can be identified by the longer bolts with nuts protruding from the bottom diaphragm case. These bolts allow the spring compression to be relieved evenly on disassembling the actuator.

- *Only open the actuator following the instructions in this document. See 'Relieving the spring compression in the actuator' in the 'Removal' section.*

⚠ WARNING

Risk of personal injury due to exhaust air being vented.

The actuator is operated with air. As a result, air is vented during operation.

- *Wear eye and hearing protection when working near the actuator.*

⚠ WARNING

Crush hazard arising from the moving actuator stem.

- *Do not insert hands or finger into the yoke while the air supply is connected to the actuator.*
- *Before working on the actuator, disconnect and lock the pneumatic air supply as well as the control signal.*
- *Do not impede the movement of the actuator stem by inserting objects into the yoke.*
- *Before unblocking the actuator stem after it has become blocked (e.g. due to seizing up after remaining in the same position for a long time), release any stored energy in the actuator (e.g. spring compression). See 'Relieving the spring compression in the actuator' in the 'Removal' section.*

WARNING

Risk of personal injury through incorrect operation, use or installation as a result of incorrect information on the actuator.

After any adjustment or conversion work, the details on the actuator nameplate may no longer be correct. This may apply, for example, to the configuration ID or the symbol after reversal of the direction of action.

- Immediately renew any nameplates or labels with incorrect or outdated information.
- Add any new values to the nameplate. If necessary, contact SAMSON to obtain a new nameplate.

NOTICE

Risk of actuator damage due to excessively high or low tightening torques.

Observe the specified torques when tightening actuator components. Excessive tightening torques lead to parts wearing out more quickly. Parts that are not tightened far enough may loosen.

- Observe the specified tightening torques (▶ AB 0100).

NOTICE

Risk of actuator damage due to the use of unsuitable tools.

- Only use tools approved by SAMSON (▶ AB 0100).

NOTICE

Risk of valve damage due to the use of unsuitable lubricants.

- Only use lubricants approved by SAMSON (▶ AB 0100).

Note

- The product warranty becomes void if service or repair work not described in these instructions is performed without prior agreement by SAMSON's After-sales Service.
- Only use original spare parts by SAMSON, which comply with the original specifications.

8.1 Periodic testing

Depending on the operating conditions, check the actuator at certain intervals to prevent possible failure before it can occur. Plant operators are responsible for drawing up an inspection and test plan.

Tip

Our after-sales service can support you in drawing up an inspection and test plan for your plant.

8.2 Preparation for servicing or conversion work

1. Lay out the necessary material and tools to have them ready for the intended work.
2. Put the actuator out of operation (see the 'Decommissioning' section).
3. Remove the actuator from the valve (see the 'Removal' section).

i Note

To remove an actuator with "stem extends" fail-safe action and/or with preloaded springs, a certain signal pressure must be applied to the actuator (see the 'Removal' section). Afterwards, the signal pressure must be removed and the air supply disconnected again and locked.

4. Relieve the compression from the preloaded springs. See 'Relieving the spring compression in the actuator' in the 'Removal' section.
5. Undo the nuts and bolts on both cases (A42, A40).

The following service and/or conversion work can be performed after preparation is completed:

- Replace the diaphragm (see section 8.4.1)
- Reverse the direction of action (see section 8.5.1)

8.3 Mounting the actuator on the valve after service or conversion work

1. Mount the actuator and connect the air supply (see the 'Mounting' section).

8.4 Service work

See Fig. 8-1

8.4.1 Replacing the diaphragm

a) Actuator stem extends

1. Lift off the top diaphragm case (A42) and remove springs (A25).
2. Unscrew the collar nut (A53).
3. Remove the diaphragm plate (A39) together with the diaphragm (A48), metal plate (A38) and actuator stem (A1) out of the bottom diaphragm case (A40).
4. Place a new diaphragm on the metal plate (A38). Place on the diaphragm plate (A39).
5. Check the sealing element on the collar nut (A53). If necessary, renew it.
6. Apply a suitable sealant and lubricant to the actuator stem (A1).
7. Insert the actuator stem (A1) together with the diaphragm plate (A39), diaphragm (A48) and metal plate (A38) into the bottom diaphragm case (A40).
8. Tighten the collar nut (A53).

Servicing and conversion

9. Place the springs (A25) in the bottom diaphragm case (A40), centering them in the intended recesses.
10. Place on the top diaphragm case (A42).
11. Fasten the top and bottom diaphragm cases (A42, A40) together with the nuts and bolts.

b) Actuator stem retracts

1. Lift off the top diaphragm case (A42).
2. Unscrew the collar nut (A53).
3. Remove the diaphragm plate (A39) together with the diaphragm (A48), metal plate (A38) and actuator stem (A1) out of the bottom diaphragm case (A40).
4. Place a new diaphragm on the metal plate (A38). Place on the diaphragm plate (A39).
5. Check the sealing element on the collar nut (A53). If necessary, renew it.
6. Apply a suitable sealant and lubricant to the actuator stem (A1).
7. Insert the actuator stem (A1) together with the diaphragm plate (A39), diaphragm (A48) and metal plate (A38) into the bottom diaphragm case (A40).
8. Tighten the collar nut (A53).
9. Place on the top diaphragm case (A42).
10. Fasten the top and bottom diaphragm cases (A42, A40) together with the nuts and bolts.

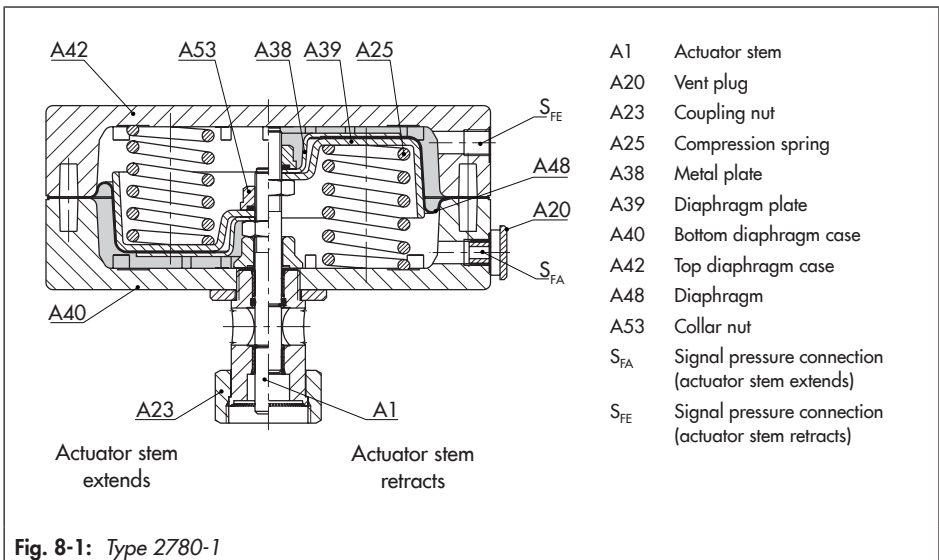

8.5 Conversion work

See Fig. 8-1

8.5.1 Reversing the direction of action (fail-safe action)

The direction of action (and fail-safe action) of pneumatic actuators can be changed. The fail-safe action is indicated on the nameplate by a symbol:

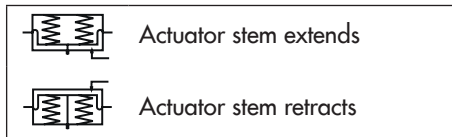

a) Reversal of the direction of action from stem extends to stem retracts

1. Lift off the top diaphragm case (A42) and remove springs (A25).
2. Pull the actuator stem (A1) together the diaphragm plate (A39), diaphragm (A48), metal plate (A38) and bushing (A46) out of the bottom diaphragm case (A40).
3. Completely unscrew the collar nut (A53), while holding the actuator stem (A1) stationary using a suitable tool which cannot damage the sealing.
4. Remove the diaphragm plate (A39) together with the diaphragm (A48) and metal plate (A38) from the actuator stem

(A1) and place them back on again turned over.

5. Tighten the collar nut (A53).
6. Apply a suitable sealant and lubricant to the actuator stem (A1).
7. Turn over the top diaphragm case (A42) and place the actuator stem (A1) together with the ready-assembled diaphragm parts inside it.
8. Slide the bushing (A46) over the actuator stem (A1).
9. Place the springs (A25) in the top diaphragm case (A42), centering them in the intended recesses.
10. Place on the bottom diaphragm case (A40).
11. Fasten the top and bottom diaphragm cases (A42, A40) together with the nuts and bolts.
12. In Type 2780-1, remove the vent plug (A20) and screw it into the bottom signal pressure connection (S_{FA}).
The actuator springs, which now push against the diaphragm plate from below, cause the actuator stem to retract. The signal pressure is connected to the top connection (S_{FE}) on the top diaphragm case. As a result, the actuator stem extends opposing the spring force as the signal pressure increases.
13. Affix a new nameplate with changed symbol and new configuration ID to the actuator.

b) Reversal of the direction of action from stem retracts to stem extends

1. Lift off the top diaphragm case (A42).
2. Pull the actuator stem (A1) together the diaphragm plate (A39), diaphragm (A48), metal plate (A38) and bushing (A46) out of the bottom diaphragm case (A40).
3. Completely unscrew the collar nut (A53), while holding the actuator stem (A1) stationary using a suitable tool which cannot damage the sealing.
4. Remove the diaphragm plate (A39) together with the diaphragm (A48) and metal plate (A38) from the actuator stem (A1) and place them back on again turned over.
5. Tighten the collar nut (A53).
6. Apply a suitable sealant and lubricant to the actuator stem (A1).
7. Slide the bushing (A46) over the actuator stem (A1).
8. Place the actuator stem (A1) together with the ready-assembled diaphragm parts into the bottom diaphragm case (A40).
9. Place the springs (A25) in the bottom diaphragm case (A40), centering them in the intended recesses.
10. Place on the top diaphragm case (A42).
11. Fasten the top and bottom diaphragm cases (A42, A40) together with the nuts and bolts.
12. Screw the vent plug (A20) into the top signal pressure connection (S_{FE}) of the Type 2780-1.
The actuator springs, which now push against the diaphragm plate from above, cause the actuator stem to extend. The signal pressure is connected to the bottom connection (S_{FA}) on the bottom diaphragm case. As a result, the actuator stem retracts opposing the spring force as the signal pressure increases.
13. Affix a new nameplate with changed symbol and new configuration ID to the actuator.

8.6 Ordering spare parts and operating supplies

Contact your nearest SAMSON subsidiary or SAMSON's After-sales Service for information on spare parts, lubricants and tools.

Spare parts

See Annex for details on spare parts.

Lubricant

See document ► AB 0100 for details on suitable lubricants.

Tools

See document ► AB 0100 for details on suitable tools.

9 Decommissioning

The work described in this section is only to be performed by personnel appropriately qualified to carry out such tasks.

⚠ DANGER

Risk of bursting due to incorrect opening of pressurized equipment or components.

Pneumatic actuators are pressure equipment that may burst when handled incorrectly.

Flying projectile fragments or components can cause serious injury or even death.

Before working on the actuator:

- ➔ Depressurize all plant sections concerned and the actuator. Release any stored energy.

⚠ WARNING

Risk of personal injury due to preloaded springs.

Actuators with preloaded springs are under tension. These actuators are marked accordingly by an adhesive label. Additionally, they can be identified by the longer bolts with nuts protruding from the bottom diaphragm case. These bolts allow the spring compression to be relieved evenly on disassembling the actuator.

- ➔ Only open the actuator following the instructions in this document. See 'Relieving the spring compression in the actuator' in the 'Removal' section.

⚠ WARNING

Risk of personal injury due to exhaust air being vented.

The actuator is operated with air. As a result, air is vented during operation.

- ➔ Wear eye and hearing protection when working near the actuator.

⚠ WARNING

Crush hazard arising from the moving actuator stem.

- ➔ Do not insert hands or finger into the yoke while the air supply is connected to the actuator.
- ➔ Before working on the actuator, disconnect and lock the pneumatic air supply as well as the control signal.
- ➔ Do not impede the movement of the actuator stem by inserting objects into the yoke.
- ➔ Before unblocking the actuator stem after it has become blocked (e.g. due to seizing up after remaining in the same position for a long time), release any stored energy in the actuator (e.g. spring compression). See 'Relieving the spring compression in the actuator' in the 'Removal' section.

To decommission the actuator for service work or before removing it from the valve, proceed as follows:

1. Put the control valve out of operation. See associated valve documentation.
2. Disconnect the pneumatic air supply to depressurize the actuator.

10 Removal

The work described in this section is only to be performed by personnel appropriately qualified to carry out such tasks.

⚠ DANGER

Risk of bursting due to incorrect opening of pressurized equipment or components.

Pneumatic actuators are pressure equipment that may burst when handled incorrectly.

Flying projectile fragments or components can cause serious injury or even death.

Before working on the actuator:

- ➔ Depressurize all plant sections concerned and the actuator. Release any stored energy.

⚠ WARNING

Risk of personal injury due to preloaded springs.

Actuators with preloaded springs are under tension. These actuators are marked accordingly by an adhesive label. Additionally, they can be identified by the longer bolts with nuts protruding from the bottom diaphragm case. These bolts allow the spring compression to be relieved evenly on disassembling the actuator.

- ➔ Only open the actuator following the instructions in this document. See 'Relieving the spring compression in the actuator' in the 'Removal' section.

⚠ WARNING

Risk of personal injury due to exhaust air being vented.

The actuator is operated with air. As a result, air is vented during operation.

- ➔ Wear eye and hearing protection when working near the actuator.

⚠ WARNING

Crush hazard arising from the moving actuator stem.

- ➔ Do not touch the actuator stem or insert hands or finger into the yoke while the air supply is connected to the actuator.
- ➔ Before working on the actuator, disconnect and lock the pneumatic air supply as well as the control signal.
- ➔ Do not impede the movement of the actuator stem by inserting objects into the yoke.
- ➔ Before unblocking the actuator stem after it has become blocked (e.g. due to seizing up after remaining in the same position for a long time), release any stored energy in the actuator (e.g. spring compression). See 'Relieving the spring compression in the actuator' in the 'Removal' section.

Before removing the valve, make sure the following conditions are met:

- The actuator is put out of operation (see the 'Decommissioning' section).

Removal

10.1 Removing the actuator from the valve

See Fig. 5-1 in the 'Installation' section.

1. **Removing actuators with "stem extends" action with/without preloaded springs:** to loosen the coupling nut (A23), apply approx. 50 % signal pressure to open the valve.
2. Loosen the coupling nut (A23) on the actuator stem (A1) and plug stem (15).
3. Disconnect the signal pressure again.
4. Lift the actuator off the valve.
5. Slide the coupling nut (A23) onto the actuator stem (A1) and tighten it.
6. Screw tight the nut (12) on the valve.

10.2 Relieving the spring compression in the actuator

The long clamping bolts with long clamping nuts and the short bolts with short nuts are arranged evenly around the circumference of the actuator housing to fasten the top and bottom diaphragm cases together. The springs in the actuator are compressed using the long clamping nuts and bolts.

To relieve the compression of the springs in the actuator, proceed as follows:

1. Unthread and remove the short nuts and bolts (including the washers) on the diaphragm cases.

2. Loosen the long clamping nuts and bolts on the diaphragm cases evenly in a crisscross pattern to gradually relieve the spring compression. Hold the bolt head stationary with a suitable tool and apply the torque to the nuts.

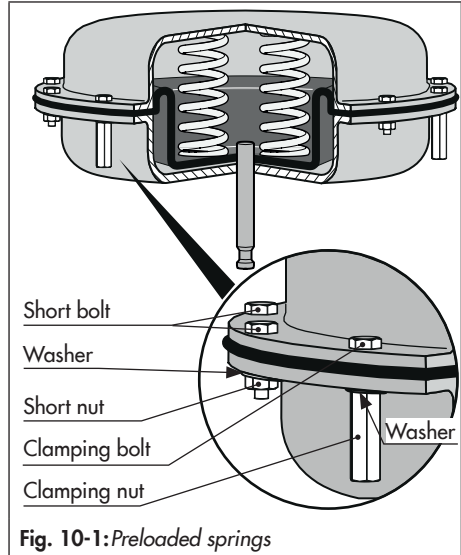

Fig. 10-1: Preloaded springs

11 Repairs

If the actuator does not function properly according to how it was originally sized or does not function at all, it is defective and must be repaired or exchanged.

! NOTICE

Risk of actuator damage due to incorrect service or repair work.

- ➔ Do not perform any repair work on your own.
- ➔ Contact SAMSON's After-sales Service for service and repair work.

11.1 Returning devices to SAMSON

Defective devices can be returned to SAMSON for repair.

Proceed as follows to return devices:

1. Exceptions apply concerning some special device models
 - ▶ www.samsongroup.com > Service > After-sales Service.
2. Send an e-mail
 - ▶ retouren@samsongroup.com to register the return shipment including the following information:
 - Type
 - Article number
 - Configuration ID
 - Original order

- Completed Declaration on Contamination, which can be downloaded from our website at
 - ▶ www.samsongroup.com > Service > After-sales Service.

After checking your registration, we will send you a return merchandise authorization (RMA).

3. Attach the RMA (together with the Declaration on Decontamination) to the outside of your shipment so that the documents are clearly visible.
4. Send the shipment to the address given on the RMA.

i Note

Further information on returned devices and how they are handled can be found at

- ▶ www.samsongroup.com > Service > After-sales Service.

12 Disposal

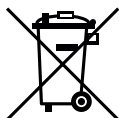

SAMSON is a producer registered at the following European institution
 ► <https://www.ewrn.org/national-registers/national-registers>.
 WEEE reg. no.: DE 62194439/
 FR 02566

- ➔ Observe local, national and international refuse regulations.
- ➔ Do not dispose of components, lubricants and hazardous substances together with your household waste.

i Note

We can provide you with a recycling passport according to PAS 1049¹⁾ on request. Simply e-mail us at offersaleservice@samsongroup.com giving details of your company address.

Tip

On request, we can appoint a service provider to dismantle and recycle the product as part of a distributor take-back scheme.

¹⁾ PAS 1049 is relevant to electrical and electronic equipment (e.g. electric actuators). This PAS specification does not apply to non-electrical equipment.

13 Certificates

These declarations are included on the next pages:

- Declaration of incorporation in compliance with Machinery Directive 2006/42/EC

The certificates shown were up to date at the time of publishing. The latest certificates can be found on our website:

▶ www.samsongroup.com > *Products* > *Actuators* > 2780

Other optional certificates are available on request.

DECLARATION OF INCORPORATION TRANSLATION



Declaration of Incorporation in Compliance with Machinery Directive 2006/42/EC

For the following products:

Type 2780-1 and 2780-2 Actuators

We certify that the Type 2780-1 and 2780-2 Actuators are partly completed machinery as defined in the Machinery Directive 2006/42/EC and that the safety requirements stipulated in Annex I, 1.1.2, 1.1.3, 1.1.5, 1.3.2, 1.3.4 and 1.3.7 are observed. The relevant technical documentation described in Annex VII, part B has been compiled.

Products we supply must not be put into service until the final machinery into which it is to be incorporated has been declared in conformity with the provisions of the Machinery Directive 2006/42/EC.

Operators are obliged to install the products observing the accepted industry codes and practices (good engineering practice) as well as the mounting and operating instructions. Operators must take appropriate precautions to prevent hazards that could be caused by the process medium and operating pressure in the valve as well as by the signal pressure and moving parts.

The permissible limits of application and mounting instructions for the products are specified in the associated data sheets as well as the mounting and operating instructions; the documents are available in electronic form on the Internet at www.samsongroup.com.

For product descriptions of the valve, refer to:

- Type 2780-1 and 2780-2 Actuator: Mounting and Operating Instructions EB 5840

Referenced technical standards and/or specifications:

- VCI, VDMA, VGB: Leitfaden Maschinenrichtlinie (2006/42/EG) – Bedeutung für Armaturen, May 2018 [German only]
- VCI, VDMA, VGB: Zusatzdokument zum „Leitfaden Maschinenrichtlinie (2006/42/EG) – Bedeutung für Armaturen“ vom Mai 2018 [German only], based on DIN EN ISO 12100:2011-03

Comments:

- See mounting and operating instructions for residual hazards.
- Also observe the referenced documents listed in the mounting and operating instructions.

Persons authorized to compile the technical file:

SAMSON AG, Weismüllerstraße 3, 60314 Frankfurt am Main, Germany
Frankfurt am Main, 06 September 2023

Stephan Giesen
Director
Product Management

Peter Scheermesser
Director
Product Maintenance & Engineered Products

Revision no. 00

Classification: Public · SAMSON AKTIENGESELLSCHAFT · Weismüllerstraße 3 · 60314 Frankfurt am Main, Germany

Page 1 of 1

14 Annex

14.1 Tightening torques, lubricants and tools

► AB 0100 for tools, tightening torques and lubricants

14.2 Spare parts

- 1 Actuator stem
- 2 Lower actuator section
- 5 Actuator stem
- 8 Top diaphragm case
- 9 Bushing
- 10 Bushing
- 20 Vent plug
- 23 Coupling nut
- 25-29 Compression spring
- 37 Threaded bushing
- 38 Metal plate
- 39 Diaphragm plate
- 40 Bottom diaphragm case
- 42 Top diaphragm case
- 45 Seal
- 46 Stop bushing
- 48 Diaphragm
- 51 Hex bolt
- 52 Hex nut
- 53 Hex nut (collar nut)
- 54 Washer
- 55 Washer
- 57 Radial shaft seal
- 58 Dry bearing
- 59 Hex nut (preloading)
- 65 Hex bolt (preloading)

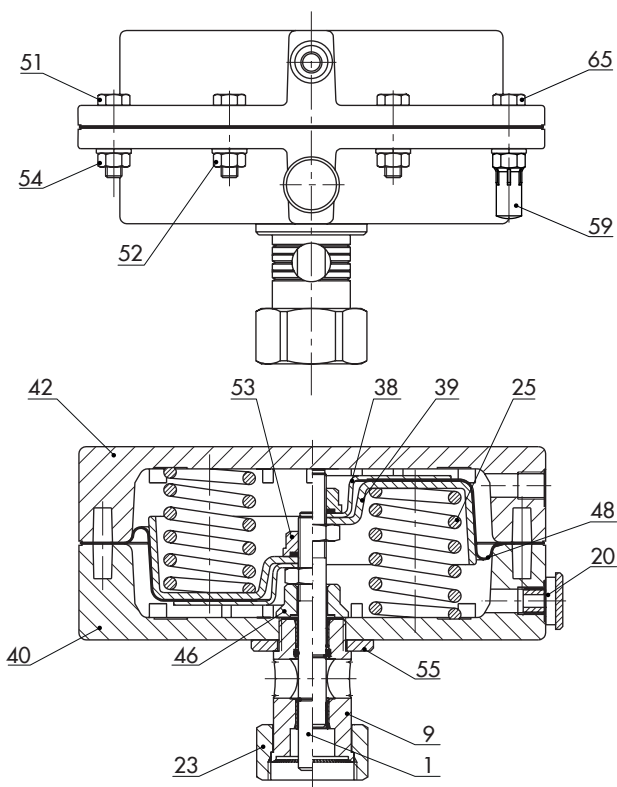

Type 2780-1 Actuator

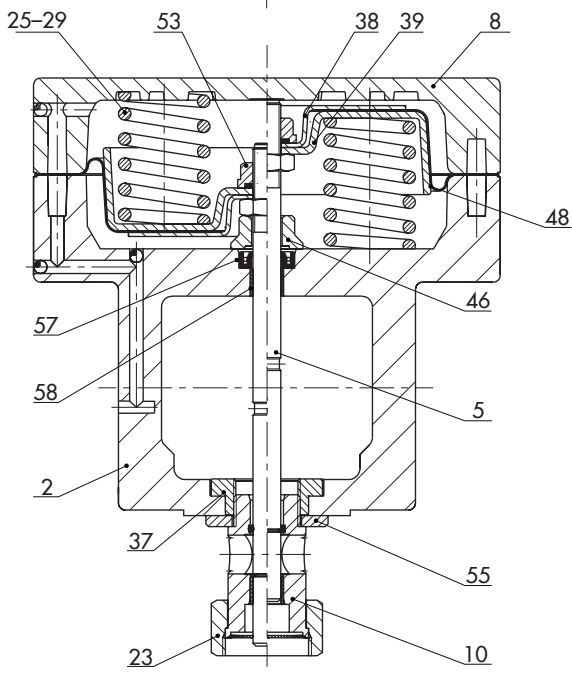
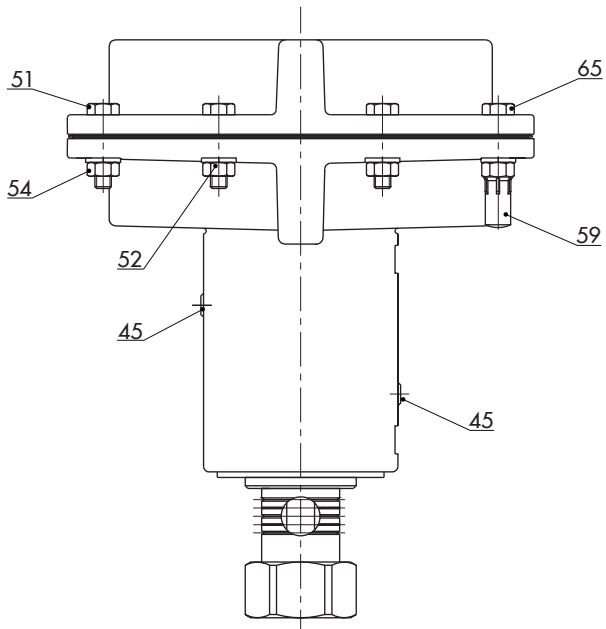

Type 2780-2 Actuator

14.3 After-sales service

Contact SAMSON's After-sales Service for support concerning service or repair work or when malfunctions or defects arise.

E-mail address

You can reach our after-sales service at aftersalesservice@samsongroup.com.

Addresses of SAMSON AG and its subsidiaries

The addresses of SAMSON AG, its subsidiaries, representatives and service facilities worldwide can be found on our website (www.samsongroup.com) or in all SAMSON product catalogs.

Required specifications

Please submit the following details:

- Order number and position number in the order
- Type, model number, actuator area, travel, direction of action and bench range (e.g. 0.4 to 1 bar) or the operating range of the actuator
- Type designation of mounted valve (if applicable)
- Installation drawing

EB 5840 EN



SAMSON AKTIENGESELLSCHAFT
Weismüllerstraße 3 · 60314 Frankfurt am Main, Germany
Phone: +49 69 4009-0 · Fax: +49 69 4009-1507
samson@samsongroup.com · www.samsongroup.com